

# HOOD PLAN CHECK GUIDE

FOR THE ENVIRONMENTAL HEALTH SPECIALIST

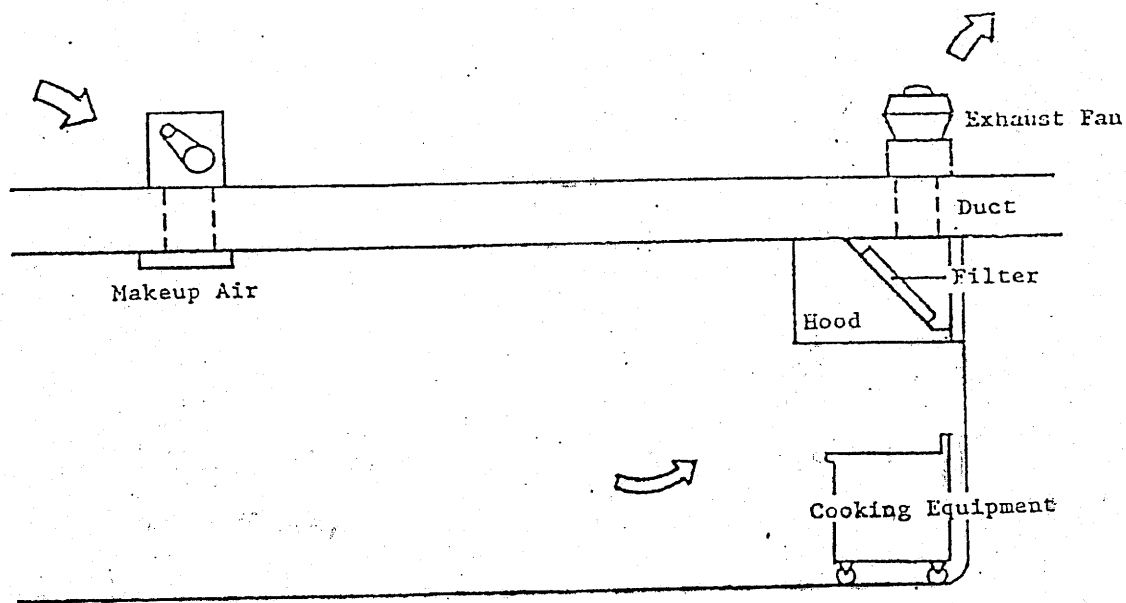

FOOD PLAN CHECK  
ENVIRONMENTAL HEALTH DIVISION  
MENDOCINO COUNTY, CALIFORNIA  
(707)463-4466  
APRIL 1998

UKIAH OFFICE

501 LOW GAP ROAD, ROOM 1326  
UKIAH, CA 95482  
(707) 463-4466  
FAX (707) 463-4038

HAZARDOUS MATERIALS  
(707) 463-5425



FORT BRAGG OFFICE

790-A1 S FRANKLIN STREET  
FORT BRAGG, CA 95437  
(707) 961-2714  
FAX (707) 961-2720

COUNTY OF MENDOCINO  
DEPARTMENT OF PUBLIC HEALTH  
DIVISION OF ENVIRONMENTAL HEALTH

REQUIREMENTS FOR HOOD PLANS

- Submit 3 sets of plans drawn to scale of 1/4 inch per foot containing the following:
  - A completed copy of the attached HOOD WORKSHEET
  - Overhead (plan) view showing:
    - Outline of hood over cooking equipment
    - Clearances around pieces of equipment & to walls
    - Exhaust & make-up air ducts
    - Exhaust & make-up air fans on roof
    - Make-up air diffusers on ceiling
    - Make & model numbers of equipment & fans
    - All dimensions of equipment & ducts
  - Front or side elevation showing:
    - Cooking equipment
    - Hood overhang
    - Duct elbows and fans
  - Type & gauge of metal used in hood & ducts
  - Specify if hood is Type I, Type II, UL Listed, non-canopy, compensating, etc.
  - Name, address & phone number of facility operator
- Submit one set of cut-sheets (manufacturers' specification sheets) for:
  - Cooking equipment
  - Exhaust fan Make-up air fan
  - UL Listing Card for hood system (if applicable)
- Plans shall conform to Uniform Mechanical Code

## HOW TO PLAN CHECK HOODS

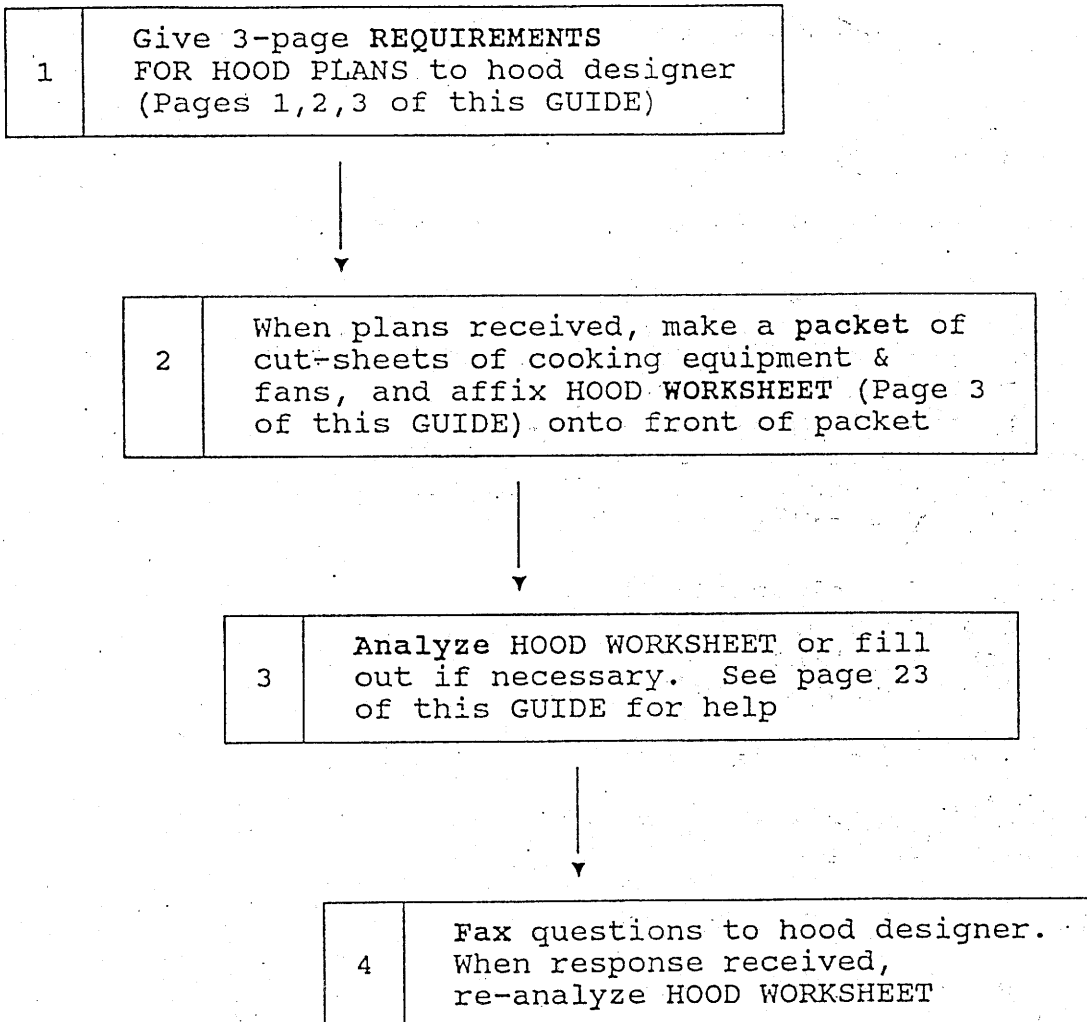

EXAMPLE OF ELEVATIONS

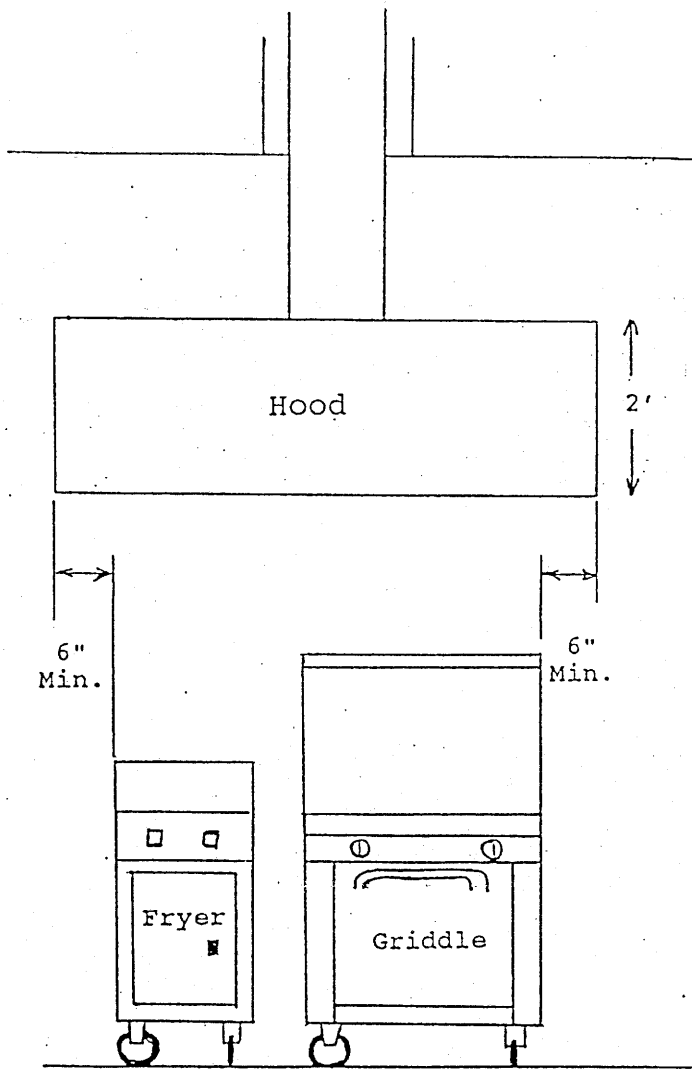

Front Elevation

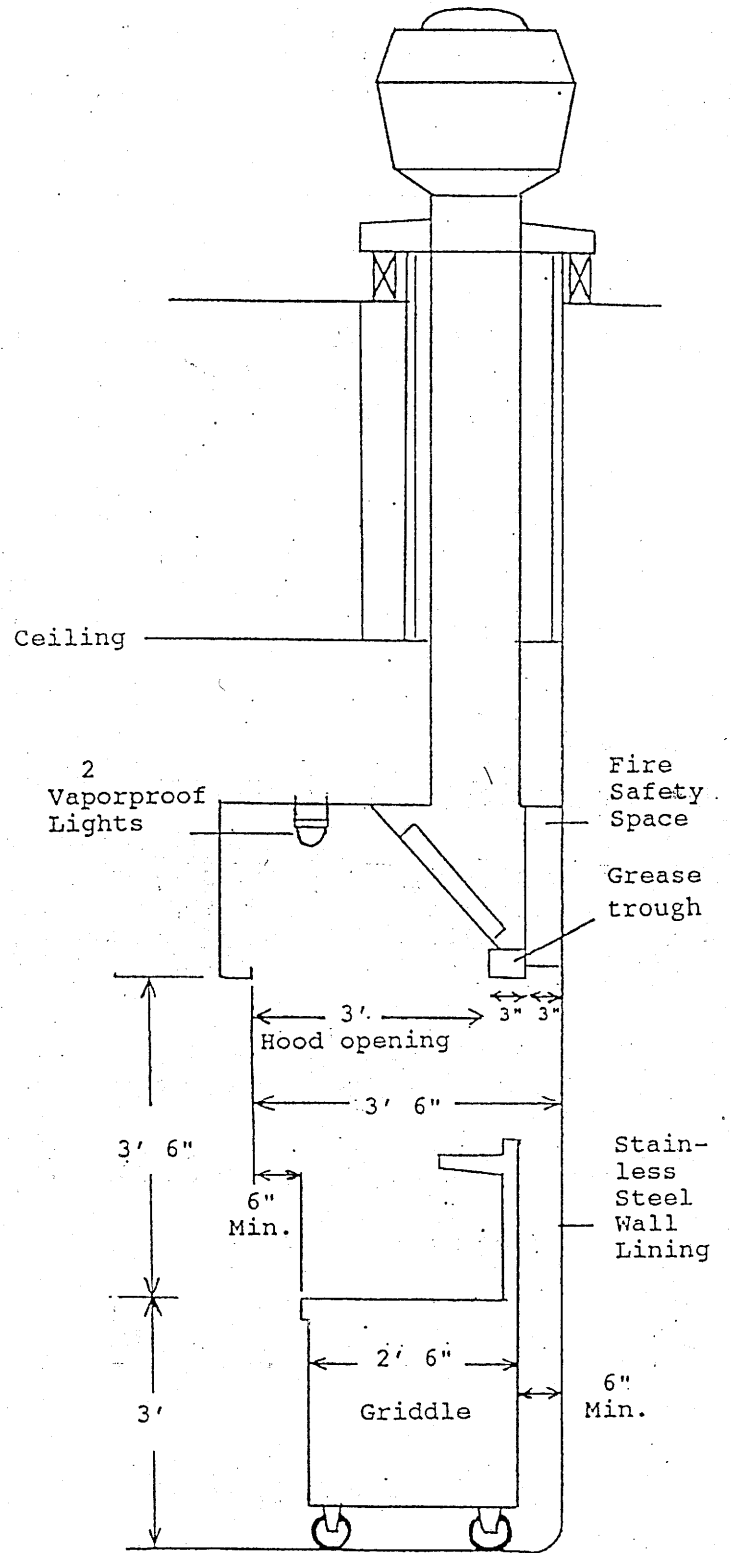

Side Elevation

HOOD WORKSHEET

Facility Name:  
Address:

COOKING EQUIPMENT & HOOD

- Fill in cooking equipment & hood dimensions in overhead view.

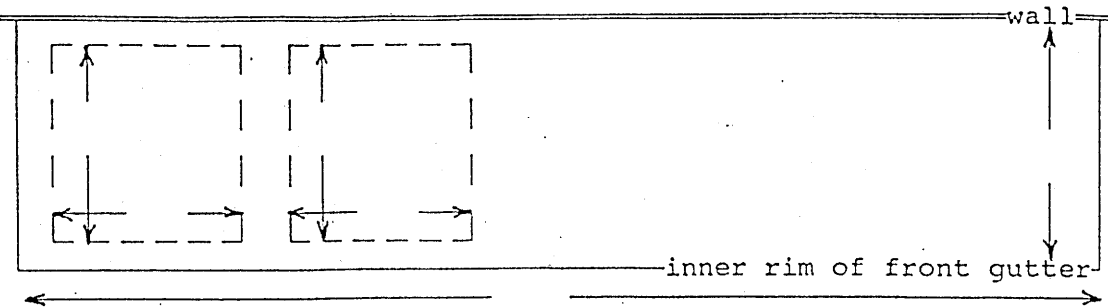

- Casters & quick disconnects

STRONGLY recommended! Specified?

- yes\_\_ no\_\_
- Hood long enough to allow  $\geq 6"$  on sides of equipment? yes\_\_ no\_\_
- Hood wide enough to allow  $\geq 6"$  in front & back of equipment? yes\_\_ no\_\_
- Canopy lip  $\geq 6.5'$  above floor &  $\leq 4'$  above cooking surface? yes\_\_ no\_\_
- Canopy free of horizontal electrical/ansul lines? yes\_\_ no\_\_

CFM

- What kind of hood? \_\_\_\_\_
- Hood opening: \_\_\_\_\_ ft. X \_\_\_\_\_ ft. = \_\_\_\_\_ sq.ft.  
(length) (width)
- \_\_\_\_\_ sq.ft. X \_\_\_\_\_ Q factor from UMC = \_\_\_\_\_ CFM
- Other formula?: \_\_\_\_\_ = \_\_\_\_\_ CFM

FILTERS

- \_\_\_\_\_ "H X \_\_\_\_\_ "W X \_\_\_\_\_ sq.ft. = \_\_\_\_\_ sq.ft.  
(Filter Size) (# of Filters) (usable area per filter) (total filter area)
- \_\_\_\_\_ CFM  $\div$  \_\_\_\_\_ sq.ft. (total filter area) = \_\_\_\_\_ fpm
- Baffle filter fpm should  $\approx 300$ ; must = 250-350. Is it? yes\_\_ no\_\_
- Horizontal slot filter fpm should  $\approx 1000$ ; must = 800-1200. Is it? yes\_\_ no\_\_ n.a.\_\_
- Total of filter widths (\_\_\_\_\_") must be  $<$  hood length. Is it? yes\_\_ no\_\_
- Fpm can be  $<$  or  $>$  above if this is a "LISTED" hood. Is it? yes\_\_ no\_\_

DUCT

- Duct dimensions: \_\_\_\_\_ X \_\_\_\_\_ = \_\_\_\_\_  $\div$  .144 = \_\_\_\_\_ sq.ft.  
(inches) (inches) (duct area)
- Hood  $>12$  ft. long shows  $>1$  exhaust outlet to main duct? yes\_\_ no\_\_ n.a.\_\_
- \_\_\_\_\_ CFM  $\div$  \_\_\_\_\_ sq.ft. (duct area) = \_\_\_\_\_ fpm
- Fpm should  $\approx 1800$ ; must = 1500-2500. Is it? yes\_\_ no\_\_

STATIC PRESSURE & EXHAUST FAN

- # of elbows = \_\_\_\_\_ Cleanout at each elbow? yes\_\_ no\_\_ n.a.\_\_
- Static Pressure  $\approx$  \_\_\_\_\_ SP
- Exhaust Fan: Make \_\_\_\_\_ Model # \_\_\_\_\_ H.P. \_\_\_\_\_
- Handles grease vapors? yes\_\_ no\_\_ Pulls CFM at SP? yes\_\_ no\_\_

MAKE-UP AIR

- \_\_\_\_\_ CFM  $\div$  2000 CFM = \_\_\_\_\_ Next higher Diffusers  
(Exhaust) (Max. per diffuser) whole number = \_\_\_\_\_ required
- Make-up air Static Pressure  $\approx$  \_\_\_\_\_ SP
- Make-up air fan: Make \_\_\_\_\_ Model # \_\_\_\_\_ H.P. \_\_\_\_\_
- Supplies 95-100% of exhaust CFM at SP? yes\_\_ no\_\_
- Make-up air on roof  $\geq 10$  ft. from exhaust? yes\_\_ no\_\_
- Diffusers on ceiling  $\geq 10$  ft. from hood? yes\_\_ no\_\_
- Exhaust & make-up air interlocked? yes\_\_ no\_\_

Prepared

by: \_\_\_\_\_ / /  
Name Phone # Company Date

## Chapter 4 VENTILATION AIR SUPPLY

402.4 Makeup Air for Commercial Kitchen Hoods. Each commercial kitchen space provided with an exhaust system shall have air supplied to the room equal to the amount of air to be exhausted. Makeup diffusers shall be located to prevent a short-circuiting of air furnished to the exhaust system. Windows and doors shall not be used for the purpose of providing makeup air. The exhaust and makeup-air systems shall be connected by an electric interlocking switch. Compensating hoods shall meet the airflow requirements specified in Sections 508.7.2 through 508.7.4. Compensating hoods shall extract at least 20 percent of their required exhaust airflow from the kitchen area.

403.1 Filters Required. Air filters shall be installed in a heating, cooling or makeup-air system. Such filters shall comply with standards for Class I or II air filters listed in Chapter 16.

## Chapter 5 EXHAUST SYSTEMS

### Part II - Commercial Kitchens

#### SECTION 507- COMMERCIAL KITCHEN HOODS AND KITCHEN VENTILATION SYSTEMS

507.1 Scope. Part II of Chapter 5 is applicable to commercial kitchen hoods and kitchen ventilation systems.

507.2 Definitions. For the purpose of Part II, the following definitions shall apply:

**COMMERCIAL FOOD HEAT-PROCESSING EQUIPMENT** is equipment used in a food establishment for heat-processing food or utensils and which produces grease vapors, steam, fumes, smoke or odors which are required to be removed through a local exhaust ventilation system.

**COMPENSATING HOOD** is a hood that has an outside air supply with air delivered below or within the hood. When makeup air is diffused directly into the exhaust within the hood cavity, it becomes a short-circuit hood.

**GREASE FILTER** is a device used to capture by entrapment, impingement, adhesion or similar means, grease and similar contaminants before they enter a duct system.

**HOOD** is an air-intake device connected to a mechanical exhaust system for collecting and removing grease, vapors, fumes, smoke, steam, heat or odors from commercial food heat-processing equipment.

Type I Hood is a kitchen hood for collecting and removing grease and smoke.

Type II Hood is a general kitchen hood for collecting and removing steam, vapor, heat or odors.

#### [DUCTS]

507.3 Grease Duct Materials. Grease ducts and plenums serving a Type I hood shall be constructed of at least 0.055-inch-thick (1.40 mm) (No.16 manufacturer's standard gage) steel or stainless at least 0.044 inch (1.10 mm) in thickness.

507.3.1 Fan casing; Exhaust fan housings serving a Type I hood shall be constructed of steel.

EXCEPTION: Fans listed as "power roof ventilators for restaurant cooking appliances."

507.3.2 Joints and seams of grease ducts. Joints and seams shall be made with a continuous liquid-tight weld or braze made on the external surface of the duct system. A vibration isolation connector may be used, provided it consists of noncombustible packing in a metal sleeve joint of approved design.

507.3.3 Grease duct supports. Duct bracing and supports shall be of noncombustible material securely attached to the structure and designed to carry gravity and lateral loads within the stress limitations of the Building Code. Bolts, screws, rivets and other mechanical fasteners shall not penetrate duct walls.

507.3.4 Nongrease ducts. Ducts and plenums serving Type II hoods shall be constructed of rigid metallic materials as set forth in Chapter 6. Duct bracing and supports shall comply with Chapter 6. Ducts subject to positive pressure shall be adequately sealed.

507.3.5 Corrosion protection. Ducts exposed to the outside atmosphere or subject to a corrosive environment shall be protected against corrosion. Galvanization of metal parts, protection with noncorrosive paints and waterproof insulation are considered acceptable methods of protection.

507.4 Prevention of Grease Accumulation. Duct Systems serving a Type I hood shall be so constructed and installed that grease cannot become pocketed in any portion thereof, and the system shall slope not less than 1/4 unit vertical in 12 units horizontal (2% slope) toward the hood or toward an approved grease reservoir. Where horizontal ducts exceed 75 feet (22 860 mm) in length the slope shall not be less than 1 unit vertical in 12 units horizontal (8.3% slope). When a centrifugal fan is used it shall be positioned so the discharge outlet is either vertical or bottom horizontal with the air so diverted that there will be no impingement on the roof, other equipment or parts of the structure. A vertical discharge fan shall be manufactured with an approved drain outlet at the bottom of the housing to permit drainage of grease to an approved collection device.

507.4.1 Grease diverter. When a centrifugal fan with bottom horizontal discharge is located outside the building, a duct or duct fitting that diverts the discharge from the grease exhaust duct system in an upward direction may be connected to the fan outlet, provided the following conditions are met:

1. The duct or duct fitting shall be constructed of metal as set forth in Tables 6-A and 6-B or U.M.C. Standard 6-2.
2. The maximum total developed length of the duct or duct fitting measured along the center line shall not exceed three times the vertical dimension of the fan outlet.
3. The duct or duct fitting shall be provided with openings at the lowest point to permit drainage of grease to an approved collection device.

507.5 Cleanouts and Other Openings. Grease duct systems shall not have openings therein other than those required for proper operation and maintenance of the system. Any portion of such system having sections inaccessible from the duct entry or discharge shall be provided with adequate cleanout openings. Cleanout openings shall be equipped with tightfitting doors constructed of steel having a thickness not less than that required for the duct. Doors shall be equipped with a substantial method of latching, sufficient to hold the door tightly closed. Doors shall be so designed that they can be opened without the use of a tool.

507.6 Duct Enclosure. A grease duct serving a Type I hood which penetrates a ceiling, wall or floor shall be enclosed in a duct enclosure from the point of penetration. A duct may only penetrate exterior walls at locations where unprotected openings are permitted by the Building Code. Duct enclosures shall be constructed as the Building Code requires shaft enclosures to be constructed. Duct enclosures shall be of at least one-hour fire-resistive construction in all buildings and shall be of two-hour fire-resistive construction in Types I and II fire-resistive buildings. The duct enclosure shall be sealed around the duct at the point of penetration and vented to the exterior through weather-protected openings. The enclosure shall be separated from the duct by at least 3 inches and not more than 12 inches (at least 76 mm and not more than 305 mm) and shall serve a single grease exhaust duct system.

507.7 Fire-resistive Access Opening. When cleanout openings are located in ducts within a fire-resistive shaft or enclosure, access openings shall be provided in the shaft or enclosure at each cleanout point. These access openings shall be equipped with tight-fitting sliding or hinged doors which are equal in fire-resistive protection to that of the shaft or enclosure.

507.8 Air Velocity. Grease duct systems serving a Type I hood shall be designed and installed in a manner to provide an air velocity within the duct system of not less than 1,500 feet per minute (7.5 m/s) and not to exceed 2,500 feet per minute (12.7 m/s).

507.9 Separation of Grease Duct System. A separate grease duct system shall be provided for each Type I hood, except that a single duct system may serve more than one hood located in the same story of the building, provided that all hoods served by the system shall be located in the same room or adjoining rooms; portions of the interconnecting ducts shall not pass through any construction which would require the opening to be fire protected as specified in the Building Code.

507.10 Clearances. Exposed grease duct systems serving a Type I hood shall have a clearance from unprotected combustible construction of at least 18 inches (457 mm). This clearance may be reduced to not less than 3 inches (76 mm), provided the combustible construction is protected with material required for one-hour fire-resistive construction.

507.11 Exhaust Outlets. Exhaust outlets for grease ducts serving commercial food heat-processing equipment shall extend

## 1994 UNIFORM MECHANICAL CODE

through the roof unless otherwise approved by the building official. Such extension shall be at least 2 feet (610 mm) above the roof surface, at least 10 feet (3048 mm) from parts of the same or contiguous buildings, adjacent property line or air intake opening into any building, and shall be located at least 10 feet (3048 mm) above the adjoining grade level.

**EXCEPTIONS:** 1. Exhaust outlets for grease ducts serving commercial food heat-processing equipment may terminate not less than 5 feet (1524 mm) from an adjacent building, adjacent property line or air intake opening into a building if the air from the exhaust outlet is discharged away from such locations.

2. Upon approval of the building official, the exhaust from any hood serving commercial food heat-processing equipment may terminate in a properly engineered air-recovery system for recirculation to the room in which the hood is located.

**507.12 Fuel-burning Appliances.** When vented fuel-burning appliances are located in the same room or space as the hood, the vent shall be arranged to prevent the hood system from interfering with normal operation of the appliance vent.

### SECTION 508 - COMMERCIAL KITCHEN HOODS

**508.1 Where Hoods Are Required.** Hoods shall be installed at or above all commercial-type deep fat fryers, broilers, fry grills, steam-jacketed kettles, hot-top ranges, ovens, barbecues, rotisseries, dishwashing machines and similar equipment which produce comparable amounts of steam, smoke, grease or heat in a food-processing establishment. For the purpose of this section a food-processing establishment shall include any building or portion thereof used for the processing of food but shall not include a dwelling unit.

**508.2 Materials and Installation.** Types I and II hoods shall be constructed of galvanized steel, stainless steel, copper or other material approved by the building official for the use intended.

**508.2.1 Type I hoods.** Type I hoods constructed of galvanized steel shall be at least 0.030 inch (0.76 mm) (No.22 gage) steel.

**508.2.2 Type II hoods.** Type II hoods shall be constructed of at least 0.024-inch (0.61 mm) (No.24 gage) steel.

Hoods constructed of copper shall be of copper sheets weighing at least 24 ounces per square foot (7.3 kg/m<sup>2</sup>). Hoods constructed of stainless steel shall have a minimum thickness of 0.030 inch (0.76 mm).

**508.2.3 Supports.** Hoods shall be secured in place by noncombustible supports.

**508.2.4 Joints and seams.** Joints and seams shall be substantially tight. Solder shall not be used except for sealing a joint or seam.

**508.3 Cleaning and Grease Gutters.** When installed, a hood shall be designed to provide for thorough cleaning of the entire hood. When grease gutters are provided, they shall drain to a collecting receptacle, fabricated, designed and installed to be accessible for cleaning.

**508.4 Clearances for Type I Hood.** A Type I hood shall be installed with clearance of at least 18 inches (457 mm) from combustible construction. This clearance may be reduced to 3 inches, provided the combustible material is protected with materials as specified for one-hour fire-resistive construction on the hood side. Hoods less than 12 inches (305 mm) from the ceiling or wall shall be flashed solidly with materials of the thickness specified in Section 508.2 or materials conforming to one-hour fire-resistive construction.

**508.4.1 Hoods penetrating a ceiling.** Type I hoods or portions thereof penetrating a ceiling, wall or furred space shall comply with all the requirements of Section 507.6.

**508.5 Grease Filters.** Type I hoods shall be equipped with approved grease filters designed for the specific purpose. Grease-collecting equipment shall be accessible for cleaning. The lowest edge of a grease filter located above the cooking surface shall be at least the height set forth in Table 5-D.

**508.5.1 Criteria.** Filters shall be of such size, type and arrangement as will permit the required quantity of air to pass through such units at rates not exceeding those for which the filter or unit was designed or approved. Filter units shall be installed in frames or holders with handles by which they may be readily removed without the use of tools, unless designed and installed to be cleaned in place and the system is equipped for such cleaning in place. They shall be sized and made removable so they may be passed through a dishwashing machine or cleaned in a pot sink and so arranged in



place or provided with drip intercepting devices as to avoid grease or other condensate from dripping into food or on food preparation surfaces.

508.5.2 Mounting position. Filters shall be installed at an angle greater than 45 degrees from the horizontal and shall be equipped with a drip tray beneath the lower edge of the filters.

508.6 Canopy Size and Location. For canopy-type commercial cooking hoods the inside edge thereof shall overhang or extend a horizontal distance of not less than 6 inches (152 mm) beyond the edge of the cooking surface on all open sides, and the vertical distance between the lip of the hood and the cooking surface shall not exceed 4 feet (1219 mm).

EXCEPTION: Listed exhaust hoods are to be installed in accordance with the terms of their listing and manufacturer's installation instructions.

508.7 Capacity of Hoods. Canopy-type commercial cooking hoods shall exhaust through the hood a minimum quantity of air determined by application of the following formulas:

WHERE:

A = the horizontal surface area of the hood, in square feet (m<sup>2</sup>).

D = distance in feet (m) between the lower lip of the hood and the cooking surface.

P = that part of the perimeter of the hood that is open, in feet (m).

Q = quantity of air, in cubic feet per minute (m<sup>3</sup>/s).

When cooking equipment is installed back to back and is covered by a common island-type hood, the airflow required may be calculated using the formula for three sides exposed. When all appliances are electric, the airflow required may be reduced to 80 percent of the formula value. Type II hood airflow requirements shall be in accordance with the requirements for low-temperature appliance hoods.

508.7.1 Solid fuel. Type I hoods for use over solid-fuel cooking equipment shall be provided with separate exhaust systems. Undefined cooking equipment other than solid-fuel cooking equipment may be installed under a common hood. The minimum airflow for solid-fuel cooking equipment, grease-burning charbroilers, and undefined equipment shall be:

Number of Exposed Sides	Formula [1]	
		For SI: (metric)
4 (island or central hood)	Q = 300A	Q = 0.46A
3 or less	Q = 200A	Q = 0.31 A
Alternate formula	Q = 100PD	Q = 0.16 PD

508.7.2 High temperature. Type I hoods when the cooking equipment includes high-temperature appliances such as deep-fat fryers:

Number of Exposed Sides	Formula [2]	
		For SI: (metric)
4 (island or central hood)	Q = 150A	Q = 0.23 A
3 or less	Q = 100A	Q = 0.16A
Alternate formula	Q = 100PD	Q = 0.16PD

508.7.3 Medium temperature. Type I hoods when the cooking equipment includes medium-temperature appliances such as rotisseries, grills and ranges:

Number of Exposed Sides	Formula [3]	
		For SI: (metric)
4 (island or central hood)	Q = 100A	Q = 0.16A
3 or less	Q = 75A	Q = 0.12A
Alternate formula	Q = 50PD	Q = 0.08PD

## 1994 UNIFORM MECHANICAL CODE

**508.7.4 Low temperature.** Type I hoods where the cooking equipment includes low-temperature appliances such as medium-to-low-temperature ranges, roasters, roasting ovens, pastry ovens and equipment approved for use under a Type II hood, such as pizza ovens:

Number of Exposed Sides	Formula [4]
4 (island or central hood)	$Q = 75A$ For SI: (metric) $Q = 0.12 A$
3 or less	$Q = 50A$ $Q = 0.08A$
Alternate formula	$Q = 50PD$ $Q = 0.08 PD$

**EXCEPTION:** Listed exhaust hoods are to be installed in accordance with the terms of their listing and the manufacturer's installation instructions.

**508.8 Capacity for Noncanopy Hoods.** In addition to all other requirements for hoods specified in this section, the volume of air exhausting through a noncanopy-type hood to the duct system shall not be less than 300 cubic feet per minute per lineal foot [ $0.043 \text{ m}^3 / (\text{s}\cdot\text{m})$ ] of cooking equipment. Listed noncanopy grease hoods and filters shall be sized and installed in accordance with the terms of their listing and the manufacturer's installation instructions.

**508.9 Exhaust Outlet.** An exhaust outlet within the hood shall be so located as to optimize the capture of particulate matter. Each outlet shall serve not more than a 12-foot (3658 mm) section of hood.

**EXCEPTION:** Listed exhaust hoods are to be installed in accordance with terms of their listing and the manufacturer's installation instructions.

**508.10 Performance Test.** Upon completion and before final approval of the installation of a ventilation system serving commercial food heat-processing equipment, a performance test may be required to verify the rate of airflow and proper operation as specified in this chapter. The permittee shall furnish the necessary test equipment and devices required to perform the tests.

## SECTION 509 - FANS, MOTORS AND SAFETY DEVICES

**509.1 General.** Motors and fans shall be of sufficient capacity to provide the required air movement as specified in this chapter. Electrical equipment shall be approved for the class of use as provided in the Electrical Code. Motors and fans shall be accessible for servicing or maintenance. Motors shall not be installed within ducts or under hoods.

**509.2 Where Required.** Approved automatic fire-extinguishing systems shall be provided for the protection of commercial-type cooking equipment.

**EXCEPTION:** The requirement for protection does not include steam kettles and steam tables or equipment which as used do not create grease-laden vapors.

**509.3 Type of System.** The system used for the protection of commercial cooking equipment shall be either a system listed for application with such equipment or an automatic fire-extinguishing system that is specifically designed for such application. Systems shall be installed in accordance with this code, their listing and the manufacturer's installation instructions. Other systems shall be an approved design of the following types:

1. Automatic sprinkler system.
2. Dry-chemical extinguishing system.
3. Carbon dioxide extinguishing system.
4. Wet-chemical extinguishing system.

**509.4 Extent of Protection.**

**509.4.1 General.** The automatic fire-extinguishing system used to protect ventilating hoods and ducts and cooking appliances shall be installed to include cooking surfaces, deep-fat fryers, griddles, upright broilers, charbroilers, range tops and grills. Protection shall also be provided for the enclosed plenum space within the hood above filters and exhaust ducts serving the hood.

**509.4.2 Carbon dioxide Systems.** When carbon dioxide systems are used, there shall be a nozzle at the top of the ventilating duct. Additional nozzles that are symmetrically arranged to give uniform distribution shall be installed within vertical ducts exceeding 20 feet (6096 mm) in length and horizontal ducts exceeding 50 feet (15 240 mm) in length. Dampers shall be installed at either the top or the bottom of the duct and shall be arranged to operate automatically upon activation of the fire-extinguishing system. When the damper is installed at the top of the duct, the top nozzle shall be immediately below the damper. Carbon dioxide automatic fire-extinguishing systems shall be sized to protect all hazards venting through a common duct simultaneously.

**509.5 Automatic Power, Fuel and Ventilation Shutoff.**

**509.5.1 General.** Automatic fire-extinguishing systems shall be interconnected to the fuel or energy source for the cooking equipment and arranged to automatically shut off equipment under the hood when the system is actuated. Shutoff valves or switches shall be of a type that requires manual operation to reset.

**509.5.2 Carbon dioxide system.** Commercial-type cooking equipment protected by an automatic carbon dioxide extinguishing system shall be arranged to shut off the ventilation system upon activation.

**509.6 Special Provisions for Automatic Sprinkler Systems.** Commercial-type cooking equipment protected by automatic sprinkler systems shall be supplied from a separate, readily accessible indicating-type control valve that is identified. Sprinklers used for protection of deep fat fryers shall be listed for that application and shall be installed in accordance with the manufacturer's installation instructions.

**509.7 Manual System Operation.** A readily accessible manual activation device installed at an approved location shall be provided for dry-chemical, wet-chemical and carbon dioxide systems. The activation device is allowed to be mechanically or electrically operated. If electrical power is used, the system shall be connected to a standby power system and a visual means shall be provided to show that the extinguishing system is energized. Instructions for operating the fire-extinguishing system shall be posted adjacent to manual activation devices.

**509.8 Fire Dampers.** Firedampers shall not be installed in a grease duct system unless listed for such use as part of a listed exhaust hood, fire-extinguishing system or an approved fan bypass.

TABLE 5-D - MINIMUM DISTANCE BETWEEN THE LOWEST EDGE OF A GREASE FILTER AND THE COOKING SURFACE OR THE HEATING SURFACE

	DUCT SYSTEM AND HOOD WITH FIRE EXTINGUISHING SYSTEM (feet)
	x 305 for mm
No exposed flame grills, french fryers, etc.	2
Exposed-flame and burners	2
Exposed charcoal and charbroil-type fires	3 1/2

CCDEH RECOMMENDATIONS<sup>1</sup> FOR CANOPY HOOD TYPE AND FORMULA

TYPE FORMULA

TYPE FORMULA

Barbecue - Solid fuel like wood/charcoal - must have separate exhaust system	I	1
Broiler <sup>2</sup>	I	3
Charbroiler - Solid fuel like wood/charcoal must have separate exhaust system	I	1
Charbroiler - Non-solid fuel like a gas charbroiler doesn't require separate exhaust system	I	1
Crepe Maker	II	4
- Large Production <sup>3</sup>	none	
- See 'Exemptions', page 21		
Dishwasher	II	4
- High-temp rinse	none	
- Chemical rinse	none	
- Undercounter		
Fryer	I	2
- Deep fat	I	2
- Pressure		
Griddle <sup>4</sup> (No holes for grease to drip through)	I	3
Grill <sup>5</sup> (Grease can drip through grate)	I	3
Gyros <sup>6</sup>	I	3
Oven	I	3
- Meat roasting	II	4
- Bread, pastry	none	
- See "Exemptions" page 21		
Pizza Oven <sup>7</sup>	I	3
- Open conveyer	II	4
- Enclosed		
Popcorn Popper	none	
- See 'Exemptions', page 21		
Range <sup>8</sup>	I	2
- High Temp	I	3
- All Others		

Rotisserie	I	3
- Open <sup>9</sup>	none	
- Low Temp <sup>10</sup>		
Salamander	I	3
Skillet <sup>11</sup> (tilting or braising)	I	3
Steam Cooker	II	4
Steam Table	none	
Toaster	II	4
- Large Production	none	
- See 'Exemptions', page 21		
Waffle Maker	II	4
- Large production	none	
- See 'Exemptions', page 21		
Wok	I	2

<sup>1</sup> California Conference of Directors of Environmental Health, 1991 Recommendations.

This Hood Plan Check Guide recommends:

<sup>2</sup> Broiler	I	1
<sup>3</sup> Crepe Maker - Large Production	I	2
<sup>4</sup> Griddle	I	2
<sup>5</sup> Grill	I	1
<sup>6</sup> Gyros	I	2
<sup>7</sup> Pizza Oven - Open Conveyer	II	4
<sup>8</sup> Range	I	2
<sup>9</sup> Rotisserie - Open	I	1
<sup>10</sup> Rotisserie - Low Temp.	I	2
<sup>11</sup> Skillet	I	2

## HEAVY DUTY QUICK-DISCONNECT GAS LINES

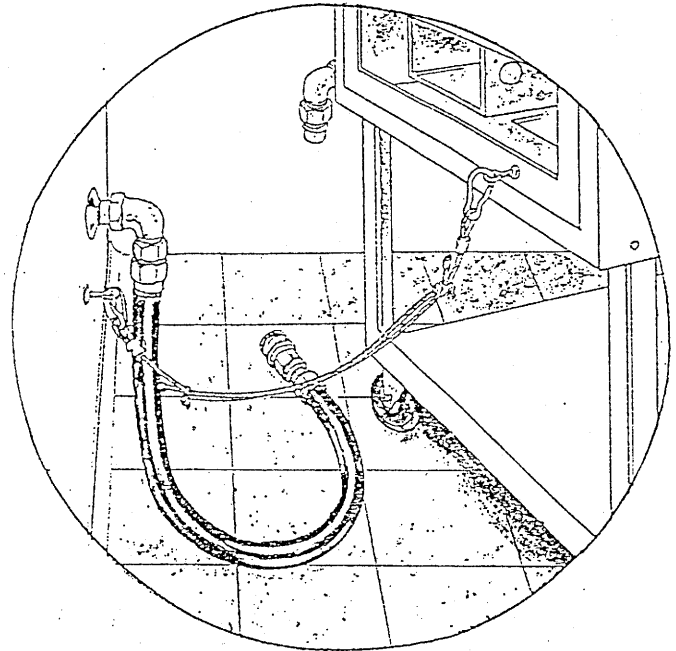
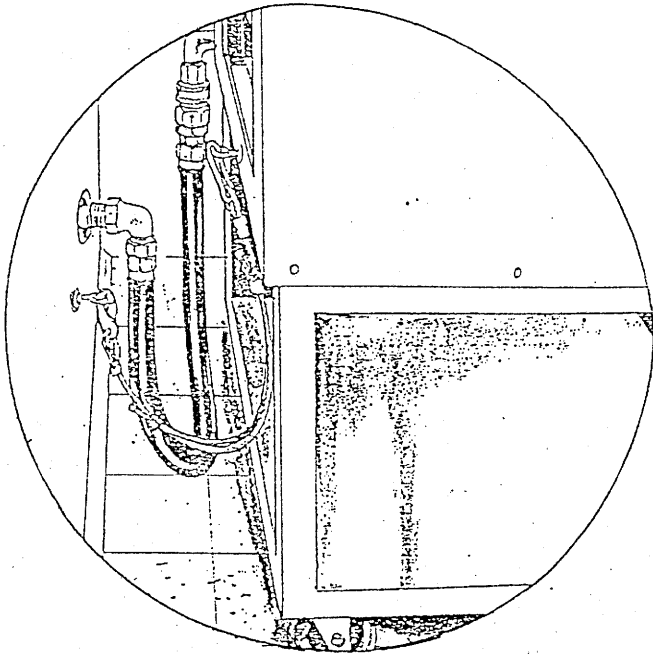

- SOME MANUFACTURERS (For information only, no endorsement implied)
  - Dormont (800)367-6668
  - T & S (800)221-2319
  - Avtec (800)262-8832

### Some Bay Area Suppliers

- East Bay Restaurant Supply, Oakland (510)465-4300
  - Economy Restaurant Fixtures, San Francisco (415)626-5611
  - Golden Bear, Alameda (510)522-5800
  - T & T, Oakland, (510)891-9567
  - Restaurant Equipment Design, Oakland (510)261-7300
  - Federighi, San Francisco (415)626-2800
- Allows equipment to be safely disconnected from gas supply and rolled out, for easy cleaning around and under equipment.
  - SPECIFY quick-disconnect lines designed for movable equipment instead of for stationary equipment.
  - A qualified PLUMBER should do the installation.
  - HEIGHT of gas supply line on wall should be 24" above floor, allowing gas line to hang in a 'lazy loop'

## FILTERS

<u>FILTER SIZES WITH FRAMES</u>		<u>Minus 1" Frames</u>		<u>USABLE FILTER AREA</u>
<u>Height</u>	<u>Width</u>			
16"	x	16"	(14" x 14")	= 1.36 sq.ft.
20"	x	16"	(18" x 14")	= 1.75 sq.ft.
→ 20"	x	20"	(18" x 18")	= 2.25 sq.ft.
25"	x	16"	(23" x 14")	= 2.24 sq.ft.
25"	x	20"	(23" x 18")	= 2.88 sq.ft.

- EXAMPLE
- 20" x 20" filter has 1" frames all around
  - Subtracting 1" frames leaves 18" x 18" interior
  - 18" x 18" = 324 sq.in.
  - 324 sq.in. ÷ 144 = 2.25 sq.ft. (usable filter area)

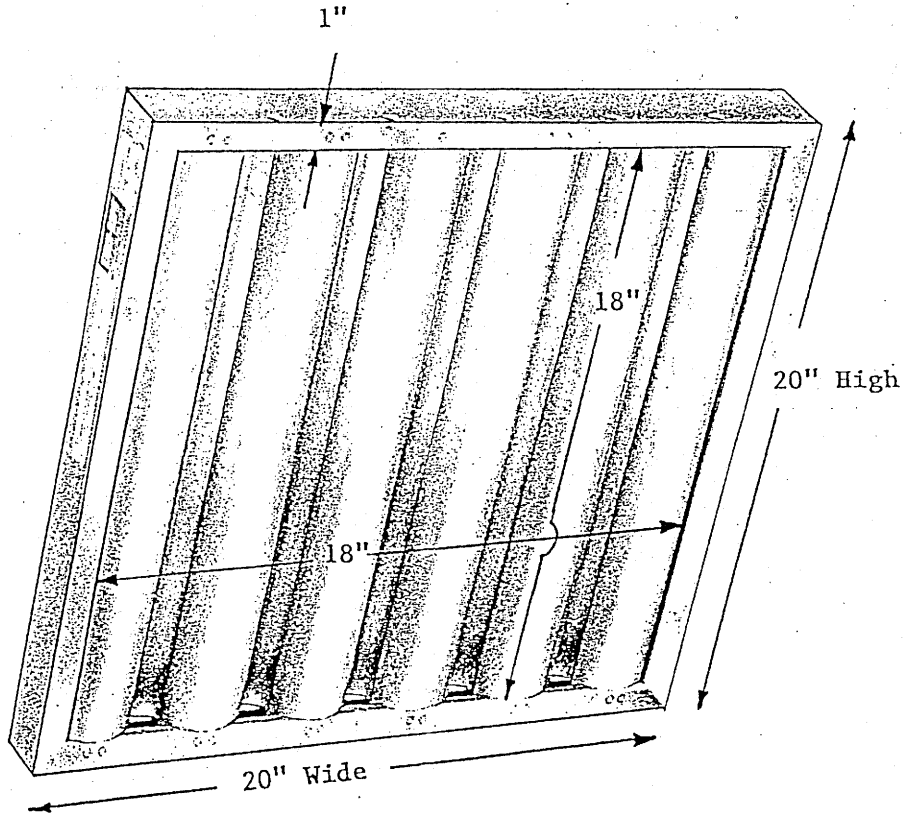

**STATIC PRESSURE**  
(Resistance to air flow)

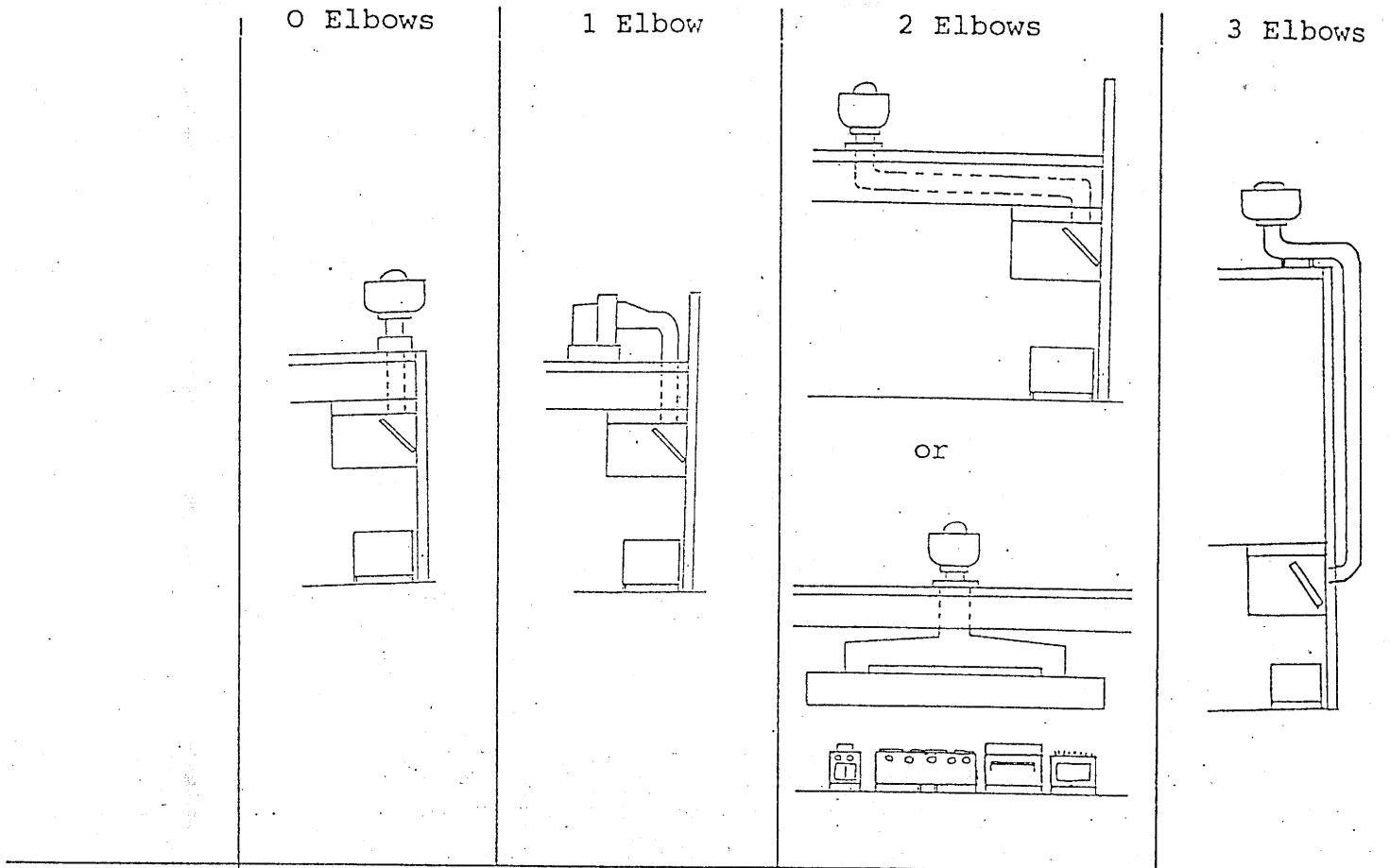

APPROXIMATE STATIC PRESSURES (SP)

TYPE I HOOD (with baffle filters)	5/8"	7/8"	1"	1 1/8"
TYPE II HOOD (without filters)	1/8"	3/8"	1/2"	5/8"
HOOD with horizontal slot filters	1 1/8"	1 3/8"	1 1/2"	1 5/8"

MAKE-UP AIR Static Pressure of .2" (.1" - .3") is commonly acceptable.

The above static pressures are for common basic situations. For complicated cases, the hood designer should calculate and provide rationale for the static pressures.

## ASSEMBLED COMMERCIAL KITCHEN VENTILATORS

**BLOWERS**

- Handle grease laden vapors up to 300°F
- For use with commercial kitchen appliances such as grills, ovens, fryers, ranges, and steam tables
- All units shipped complete with motor
- Aluminum housing and wheel with epoxy coated steel base assembly

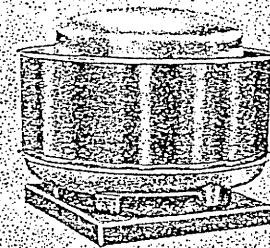
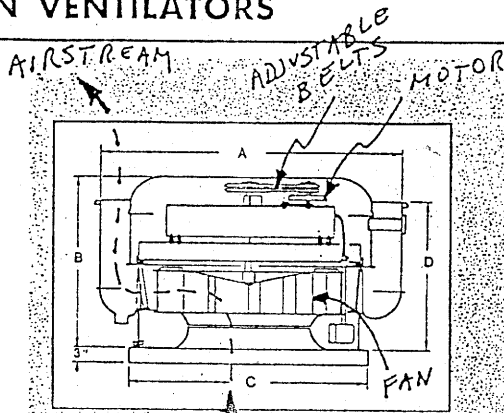

Adjustable pitch sheave permits speed and air delivery adjustment range of up to 30%. Motor and drive assembly is isolated from discharge airstream and is force cooled by outside air.

3/4 and 1 1/2 HP motors are rated 115/230V. 1/2 HP motor is 115V only. 2 HP, 3-phase motor rated 200/230/460 volts. Continuous duty open dripproof motor wired for 115V, or 230V 3-phase, to externally mounted disconnect switch.

UL Listed in Fire Protection Equipment Directory under Power Ventilators for Restaurant Appliances (YZHW), Subject 762.

Optional hinge curb accessory kit (listed below), order separately. Allows ventilator to be lifted from curb for cleaning wheel, lower housing, and duct work. Ventilators must be mounted on 18" high steel roof curb to comply with NFPA 96 and UL Guide YZHW. Dayton brand.

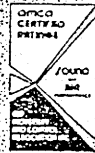

Dayton Electric Mfg. Co. certifies that the ventilators shown herein are licensed to bear the AMCA Seal. The ratings shown are based on tests and procedures performed in accordance with AMCA Publication 211 and AMCA Publication 311 and comply with the requirements of the AMCA Certified Ratings Program.

The Sound Ratings shown are loudness values in fan sones at five (5) feet in a hemispherical free field calculated per AMCA Standard 301. Values shown for ventilators listed are for Installation Type A - Free Inlet sones.

### VENTILATOR PERFORMANCE

Wheel Dia	CFM Air Delivery @ Static Pressure Shown										RPM Range	Motor HP	Peak BHP*	Sones @ 1/2" SP	Recommended 18" Vent Curb Stock No.
	Free Air	1/4" SP	1/2" SP	3/4" SP	1" SP	1 1/4" SP	1 1/2" SP	1 3/4" SP	2" SP	2 1/4" SP					
13 1/2"	1430	1195	880	355	—	—	—	—	—	—	1240	1/2	0.18	9.4	5C539
	1500	1350	1090	700	450	—	—	—	—	—	1360		0.24	11.6	
	1700	1500	1300	1000	800	580	—	—	—	—	1485		0.30	13.1	
	1850	1660	1480	1240	1030	900	470	—	—	—	1605		0.37	14.6	
	1980	1810	1645	1440	1325	1180	805	—	—	—	1725		0.46	16.1	
	2130	1960	1810	1635	1520	1415	1135	780	—	—	1845		0.56	18.2	
16 1/4"	2280	1920	1450	745	—	—	—	—	—	—	1070	3/4	0.26	9.7	5C540
	2480	2160	1795	1220	880	—	—	—	—	—	1170		0.33	11.8	
	2685	2400	2080	1620	1350	1030	—	—	—	—	1270		0.43	14.1	
	2900	2640	2350	1990	1750	1490	900	—	—	—	1370		0.53	16.3	
	3110	2860	2595	2300	2115	1875	1380	—	—	—	1470		0.65	18.0	
	3340	3100	2855	2590	2440	2265	1830	1345	—	—	1570		0.82	19.8	
20"	3415	3160	2910	2590	2375	2140	800	—	—	—	1070	1 1/2	0.61	11.0	5C540
	3660	3425	3200	2900	2775	2575	2025	—	—	—	1150		0.75	12.6	
	3930	3715	3500	3260	3150	2995	2625	1990	—	—	1235		0.94	14.4	
	4170	3980	3770	3580	3460	3280	3020	2650	—	—	1315		1.14	16.1	
	4440	4250	4080	3885	3780	3675	3415	3100	—	—	1395		1.35	17.9	
	4710	4525	4340	4165	4080	3980	3765	3490	—	—	1475		1.59	19.9	
24 1/2"	4730	4350	3960	3510	3250	2855	—	—	—	—	860	2	0.77	10.8	5C541
	5560	5125	4680	4280	4050	3790	3050	—	—	—	925		1.06	12.2	
	5970	5560	5135	4740	4555	4330	3800	2945	—	—	990		1.31	14.0	
	6365	5970	5575	5190	5010	4815	4400	3835	—	—	1055		1.57	15.6	
	6435	6120	5760	5645	5440	5310	4900	4500	—	—	1120		1.88	17.6	
	6540	6265	5990	5715	5550	5425	5095	4750	—	—	1190		2.02	20.0	

Performance shown is for units without inlet or outlet ducts.

(\*) Peak brake horsepower over catalog range. Motors are sized on the basis of internal temperature rise—rather than nameplate horsepower. BHP does not include drive losses.

### VENTILATOR ORDERING DATA

Wheel Dia	Dimensions in Inches				HP	Motor Data Volts/Phase	Stock No.	List	Each	Shpg. Wt.
	A	B	C	D						
13 1/2"	31 1/2	22 1/8	24	22 1/4	1/2	115 1 ph	3C501	\$1130.65	\$677.50	105.0
16 1/4"	36	23 1/8	28	22 1/4	3/4	115/230 1 ph	3C502	1359.75	814.50	115.0
20"	36 3/8	27 1/4	28	22 1/4	1 1/2	115/230 1 ph	3C503	1864.57	1117.00	195.0
24 1/2"	42 1/2	28 3/8	34	23 1/4	2	200/230/460 3 ph	3C549	1842.73	1104.00	304.0

Optional Hinge Kit Assembly. Allows ventilator to be easily lifted off curb for cleaning the lower housing, wheel and duct work.

No. 4C755. Shpg. wt. 3.7 lbs. List \$78.60. Each.....\$47.10

LET US SUPPLY YOUR FANS, VENTILATORS AND RELATED PRODUCTS

SEE WARRANTY INFORMATION ON PAGE OPPOSITE INSIDE BACK COVER

2467



**AC & REFRIGERATION**

**EVAPORATIVE COOLING SYSTEMS**

- Energy efficient, rugged blower motor
- Roto-Belt® system replaces pump
- Unique Roto-Belt® pad keeps its shape and thickness for superior water evaporation and air filtration
- Blower housing is welded to cooler which provides smooth, quiet operation
- Low silhouette and easily converted from down to side discharge
- Nonrusting PVC air louvers
- Nonrusting PVC plastic reservoirs
- Moisture-protected blower motor

**UL**

**ENERGY RIGHT**

**ESSICK**  
The cool one

**No. 3EC18**

**RUSTED BLOWER MOTOR**  
Low energy consumption motor designed for long, reliable life.

**ROTO-BELT SYSTEM REPLACES PUMP.** Pump and water distribution tube problems eliminated by Roto-Belt system.

**LOW SILHOUETTE**  
CABINET is easily converted from down to side discharge.

**NONRUSTING AIR LOUVERS**

**NONRUSTING PVC PLASTIC RESERVOIR**

**ROTO-BELT PAD** Durable, abrasion resistant polyester pad keeps its shape and thickness for superior water evaporation and air filtration.

Roto-Belt® evaporative coolers are designed for long lasting service. All water contact parts such as water reservoirs, louvers and lower frames are constructed of "rustfree" PVC plastic. Evaporative cooling is used where mechanical air conditioning is too expensive to use or where cooled air cannot be recirculated as in factories, dry cleaners, laundries, and restaurant kitchens. Also used in homes, apartments, garages, shops and green houses. Approximately 80% more economical than air conditioning.

Motor-driven blower draws hot outside air through "twin" rotating polyester filters in PVC plastic frames which turn through two PVC plastic water reservoirs that cannot rust. Cooler can be converted from down discharge, to side discharge in minutes. (Switch and grille not included.)

Units replace all existing evaporative cooling systems. Roto-Belt evaporative coolers are used in place of aspen-type coolers where rust and corrosion of such products are undesirable.

Evaporative cooling in residential use is restricted to states where relative humidity is not over 50%. It is however, used in practically every state in commercial applications, industrial uses and make-up air in restaurant kitchens. Galvanized steel housing with neutral sand color baked enamel finish. UL Listed. Essick brand.

Sizing Airflow Rating	Wind Tunnel CFM	Dimensions, Inches			Motor Data (110-120V, 60 Hz)			Air Output Opening, In.	Essick Model	Stock No.	List	Each	Shpg. Wt.
		H	W	D	Speeds	HP	Volts						
3300	2000	25 3/4	29 3/4	25 1/4	2	1 1/3	115	13 3/4"H 13 3/4"W	ECR3300	3C466	\$607.00	\$466.00	107.0
4000	3000	29 3/4	36	29 3/4	2	1 1/3	115	17 3/4"H 17 3/4"W	ECR4000	3C467	719.00	548.00	141.0
4500	3600	29 3/4	36	29 3/4	2	1 1/2	115	17 3/4"H 17 3/4"W	ECR4500	3EC18	754.00	564.00	150.0
5200	4000	33 3/4	37 1/2	33 3/4	2	1 1/2	115	19 3/4"H 19 3/4"W	ECR5200	3C468	929.00	713.00	185.0
6600	5000	36 3/4	42 3/4	36 3/4	2	3/4	115	19 3/4"H 19 3/4"W	ECR6600	3C469	1015.00	781.00	236.0
7200	5600	36 3/4	42 3/4	36 3/4	2	1	115	19 3/4"H 19 3/4"W	ECR7200	3EC19	1064.00	832.00	234.0

**SIZE SELECTION GUIDE FOR ESSICK EVAPORATIVE COOLING SYSTEMS**

Since the amount of air through the wetted surfaces creates the cooling effect, the volume of air delivered or how often the room air is changed determines the unit selection. Lower relative humidities result in cooler discharge air and a slower change rate. Areas of the country with generally similar humidity levels can be grouped together in zones with common air change requirements. These zones are shown on the map at right.

**EXAMPLE.** A house in Phoenix Arizona is 40 ft long by 20 ft wide with 8-ft ceiling. The house is well insulated and is not exposed to unusual heat sources.

1. 40 x 20 x 8 = 6400 cubic feet.
2. House is located in zone 3.
3. Minutes per air change = 2.
4. 6400 cubic ft ÷ 2 = 3,200.
5. At 0" static pressure, order No. 3C468.

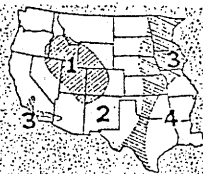

Knowing the typical area outdoor temperature and relative humidity, Refer to Cooler Discharge Temperature chart to determine if the discharge air temperature will be acceptable for the application. If acceptable, proceed to step no. 1.

**"MINUTES PER AIR CHANGE CHART"**

Interior Heat Load†	Exterior Heat Load‡	Minutes per Air Change			
		Zone 1	Zone 2	Zone 3	Zone 4
High	Exposed	2	1.5	1.3	0.7
High	Insulated	3	2	1.5	1
Normal	Exposed	3	2	1.5	1
Normal	Insulated	4	3	2	1.3

(†) High designates places with unusual heat sources from hot equipment or processes, crowded conditions, etc. Normal designates absence of unusual heat sources, such as a typical home or office.

(‡) Exposed designates walls and roof exposed to sun, poor insulation, etc. Insulated designates walls and roof well insulated and/or shaded.

1. Calculate cubic feet of area to be cooled. Multiply building length x width x height.
2. Determine your zone number by locating the installation on the map at right.
3. Determine minutes per air change by referring to table at right.
4. Determine CFM required, Divide cubic ft. (figure from No. 1) by number of minutes per air change (figure from No. 3).
5. Refer to Performance Chart at right. Under CFM Air Delivery section, find required CFM at expected static pressure. If CFM falls between models, choose next larger model.

Outside Dry Bulb Temperature	Outside Relative Humidity							
	5%	10%	15%	20%	30%	40%	50%	60%
80°F	56°F	58°F	60°F	61°F	64°F	67°F	69°F	72°F
90	62	64	66	68	72	75	78	81
100	68	70	73	75	79	83	87	90
110	74	77	80	82	87	92	95	—
120	79	83	86	89	95	100	—	—

  

Stock No.	Industry Rating Air Flow	CFM Air Delivery					
		Free Air (0" SP#)	0.1" SP	0.2" SP	0.3" SP	0.4" SP	0.5" SP
3C466	3300	2310	2140	1980	1900*	1860*	1740*
3C467	4000	3110	2860	2560	2330	2120*	1890*
3EC18	4500	3560	3274	2930	2667	2427	2164*
3C468	5200	4010	3770	3410	3020	2980*	2460*
3C469	6600	5090	4830	4620	3940	3610*	3340*
3EC19	7200	5602	5316	5084	4336	3973	3676

(#) Sp = Static Pressure. (\*) Requires 3 3/4" diameter variable pitch motor pulley, not furnished. Use variable-pitch cast-iron sheave No. 3X274; see page 248.

USE THESE FIGURES

FIELD TESTING

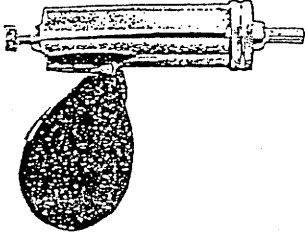
<p><u>Powder Gun</u></p>  <p>Tests ability of hood to capture air</p>	<p>Quickly and firmly squeeze bulb several times to get a big cloud over cooking surface</p>		
	<p><u>Observation</u></p> <p>Powder gets blown around into room</p>	<p><u>Problem</u></p> <p>Make-up air may be creating turbulence over cooking surfaces</p>	<p><u>Solution May Be</u></p> <p>Move make-up diffusers farther from hood</p> <p>Add more diffusers</p> <p>Redirect louvers on diffusers</p>
	<p>Powder doesn't get drawn up into hood</p>	<p>Insufficient CFM or inadequate overhang</p>	<p>Ensure that system is installed per plan</p>

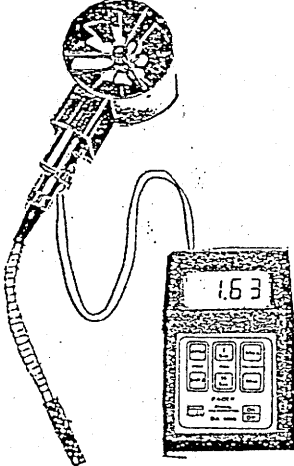
<p><u>Anemometer</u></p>  <p>Tests ability of filters to collect grease</p>	<p>Hold test probe 1" from open slot at center of each filter.</p>		
	<p>Baffle filter fpm should <math>\approx</math> 300, must be 200 - 400. Horizontal slot filter fpm should <math>\approx</math> 1000, must be 700 - 1300. Fpm for "Listed" hoods may be &lt; or &gt; than above</p>		
	<p><u>Observation</u></p> <p>Speed too low</p>	<p><u>Problem</u></p> <p>Grease stays in air at low speed and does not impinge on filters</p>	<p><u>Solution May Be</u></p> <p>Increase exhaust RPM</p> <p>Add some blank filters</p>
<p>Speed too high</p>	<p>Air at too high speed scours grease that was impinged on filters</p>	<p>Decrease exhaust RPM</p>	

Bottom Line: Record observations and give written directives to:

- Ensure that system is installed per approved plan
- Correct situation so as to achieve good powder test, fpm through filters of 200 - 400, and compliance with UMC

TYPE II HOOD

No ansul system

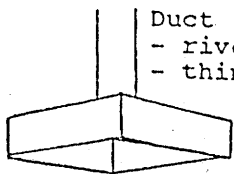

Duct  
- riveted, not welded  
- thinner gauge metal

18" overhang over door

No filters

DISHWASHER (high-temp rinse)

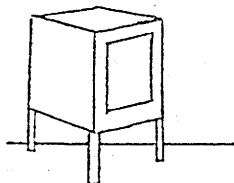

OVEN (for bread not meat)

UMC Formula 4

\_\_\_\_\_sq.ft. X 50 = \_\_\_\_\_CFM  
(hood area) (usually) (required)

HOOD WORKSHEET:

- Skip FILTERS step.
- STATIC PRESSURE, see page 14
- EXHAUST FAN does not have to be UL rated for grease.

BACKSHELF VENTILATOR  
(Non-Canopy Hood)

For distance between filters & cooking surface, see UMC table 5-d

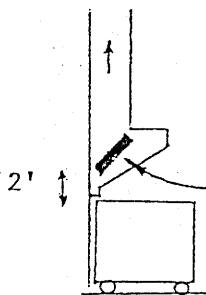

Recommended for:

- fryer
- griddle
- wok

Not recommended for

- range: because large pots block airflow
- charbroiler: because flames can hit filter
- oven: because door opens in front

Formula UMC 508.8:

\_\_\_\_\_ft. X 300 = \_\_\_\_\_CFM  
(hood length)

OVEN OVERHANG  
TYPE I HOODS

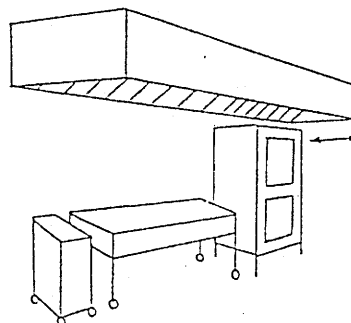

18" front overhang (12"-24" in some cases)

For large tall ovens like:

- double stack convection oven
- open pizza oven
- BBQ oven

Large tall ovens need more than the minimum 6 inch front overhang to inner hood rim required by UMC 508.6.

EXTRALARGE BAKERY OVENS

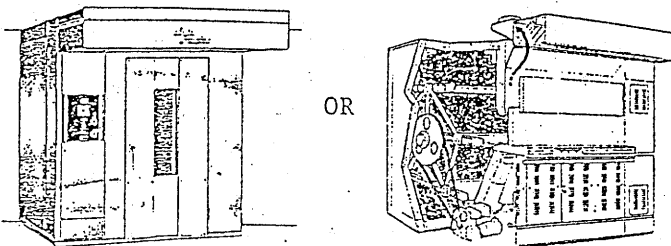

EYEBROW hoods (shown above) are ineffective in capturing huge amounts of heat. Require mechanical ventilation of at least 1500 CFM through a duct through the ceiling within 5 - 15 feet from oven.

Plan view (overhead) of room

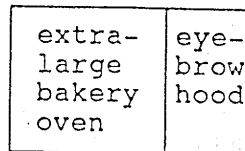

a separate duct through ceiling to roof exhaust fan

LISTED HOODS

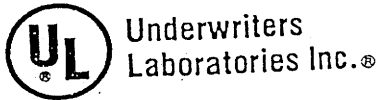

- Listed hoods do not follow all UMC requirements. Use the following procedures when plan checking:
- Request all items in REQUIREMENTS FOR HOOD PLANS plus Make & Model # of hood and UL listing card.

Example of UL Listing Card:

YXZR Exhaust Hoods With Exhaust Dampers  
 GAYLORD INDUSTRIES INC., TUALATIN OR 97062 MH11403  
 Automatic damper and hood for restaurant cooking appliances.

Model(s)	Length, Ft	CFM/ft. of hood length	Max Supply	Cooking Surface Temp, F
AB-++-++-++-++-++	2-16	140	NA	400
AB-++-++-++-++-++	2-16	250	NA	600
AB-++-++-++-++-++	2-16	140	NA	400
AB-MAR(MAW)-++-++-++-++-++	2-16	250	NA	600
AB-MAR(MAW)-++-++-++-++-++	2-16	250	NA	400
BO-++-++-++-++-++	3-16	150	NA	600
BO-++-++-++-++-++	3-16	250	NA	700
BO-++-++-++-++-++	3-16	340	NA	600
BDL-++-++-++-++-++	3-16	150	NA	400
BDL-++-++-++-++-++	3-16	240	NA	600
BDL-++-++-++-++-++	3-16	350	NA	700
BDL-++-++-++-++-++	3-16	150/240	NA	400/600
BDL-DS-++-++-++-++-++	3-16	240/350	NA	600/700

EXAMPLE DO NOT USE

HORIZONTAL SLOT FILTERS

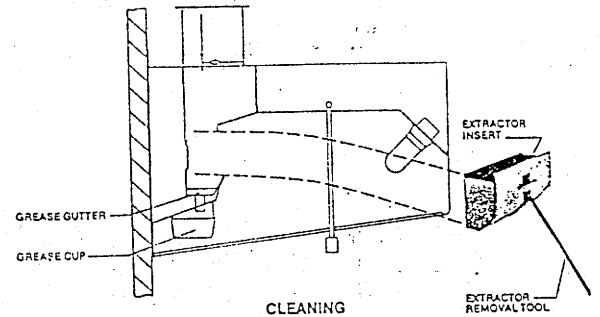
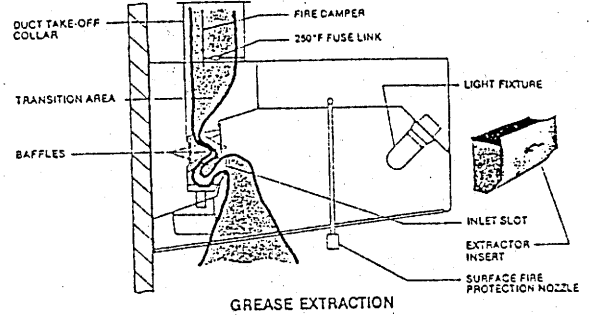

- Filter air speed should be approx. 1000 fpm, but can vary widely depending on manufacturer's UL specs.
- Static pressure, see page 13

COMPENSATING HOODS

At least 20% of required make-up air must come from room make-up air system. (UMC 402.4)

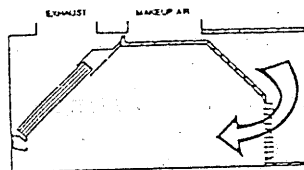

INTERNALLY COMPENSATING

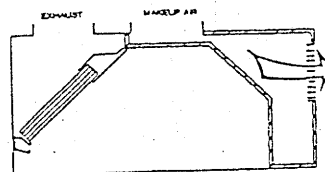

EXTERNALLY COMPENSATING

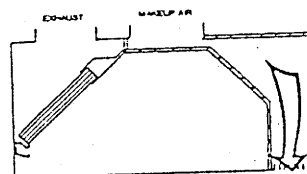

DOWN DISCHARGE COMPENSATING  
 Not recommended for most cooklines as air blows down onto cook's head

- Analyze HOOD WORKSHEET as usual, except in "CFM" section, "Other Formula" is derived as follows:
- Look at listing card; find hood model # in far left column. Go to far right column and find Temp F. Verify that it is ≥ temperature of cooking equipment proposed, according to following:

- 700°F Wood/charcoal charbroilers
- 600°F Regular charbroilers
- 400°F Most cooking equipment

- On listing card, go to column labeled "CFM/ft. of hood length". Plug that number into this formula:

$$\frac{\text{CFM/ft. of hood length}}{\text{of hood length}} \times \text{ft. (hood length)} = \text{CFM}$$

- Continue HOOD WORKSHEET except in "DUCT" section, hoods over 12 feet long do not require more than one duct.

IMPROVING HOODS

- Change of Ownership Inspection
- Poorly working hood

IF kitchen too hot, greasy, noisy:

- Test hood (especially powder gun)
- Direct Operator to:
  - Have hood & ducts steam cleaned
  - Have hood contractor inspect & tune up system

Also see suggested Solutions on page 16 of this Guide.

(For Hood Contractors, look in Yellow Pages: "Restaurant Equipment, Services & Supplies")

IF increased airflow needed:

Hood Contractor may add end panels whose lower edges extend below cooking surface, (with approved plans)

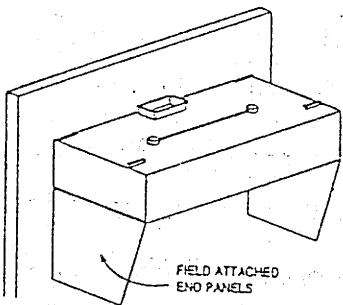

ALTERNATE FORMULA=  $Q = 100PD$  (UMC 508.7)

IF front overhang insufficient:

Hood Contractor may install spacer to move hood out. (with approved plans)

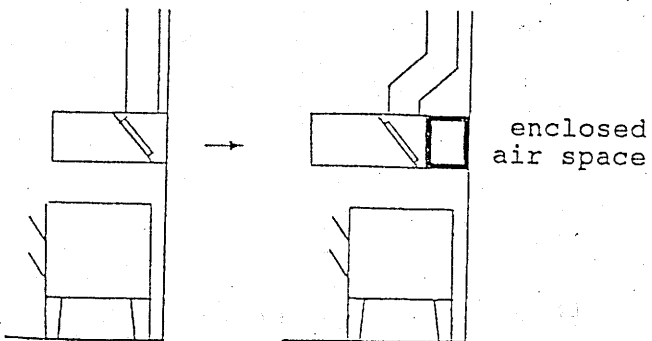

ONE OPEN-SIDED HOOD

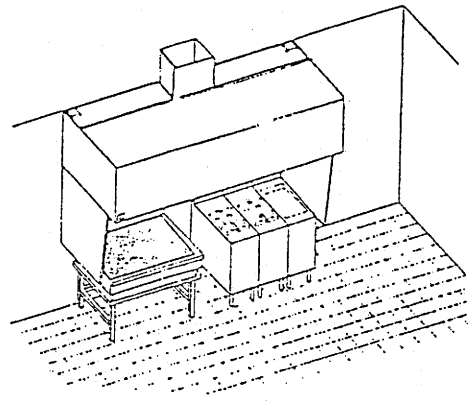

Excellent hood for charbroiler, it requires less CFM than a 4,3, or 2 open-sided hood.

ALTERNATE FORMULA=  $Q = 100PD$  (UMC 508.7)

$$100 \times \text{ft. (P)} \times \text{ft. (D)} = \text{CFM (required)}$$

(the part of the perimeter that is open) (distance between lower lip of hood & cooking surface, often 3.5 ft.)

(P) (D)

ISLAND HOOD  
(FOUR OPEN-SIDED HOOD)

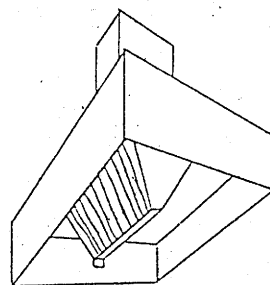

V-Bank Filter

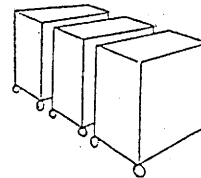

Large volume of air required by a four open-sided hood can be best handled by a V-Bank filter.

For formulas, see UMC 508.7

TWO HOODS  
ON COMMON DUCT

Hoods side-by-side

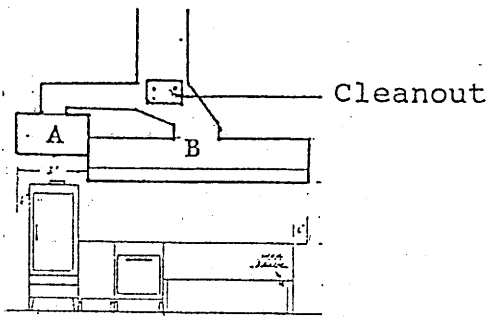

- HOOD WORKSHEET: do calculations for hoods A and B separately.
- Then add up calculations to get total CFM, combined duct size, total Static Pressure, one exhaust fan, etc.

EXEMPTIONS (NO HOOD)

Use good judgement and Department policy in weighing factors:

- Unit will be used for non-greasy items (eg: breads or pre-cooked meats like hot dogs not raw meats or fried foods)
- In use only a short time each day.
- Electric not gas.
- Room is large and well ventilated, and has few heat-producing units. (Can room ventilation be improved?)
- State Health Department letter states that a hood may not be required.
- CCDEH RECOMMENDATIONS LIST shows that a hood is not required.
- Unit is small and portable.
- Owner agrees to remove unit if problems occur.
- Maximum temperature of 250°F.

SPLIT EXHAUST DUCT

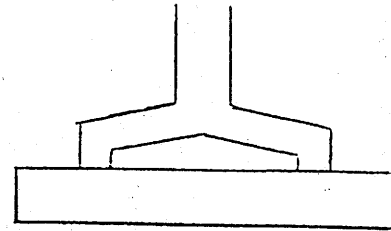

hood length over 12 feet  
requires more than one duct  
UMC 508.9

HOOD WORKSHEET: Do all calculations based on main duct.

Then verify that the combined sizes of the smaller ducts approximately equals the main duct.

VENTLESS HOODS  
(Ductless)

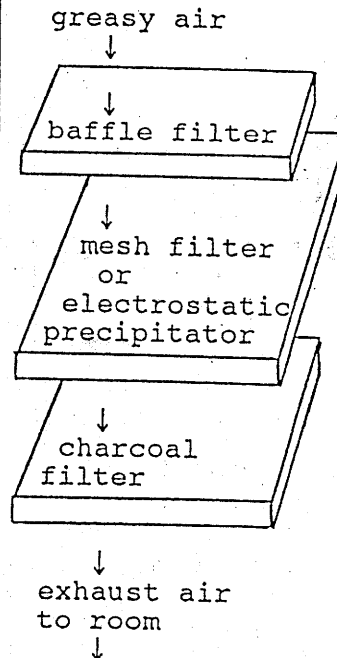

What They Are

- Self-contained hoods
- Greasy air processed through several filters
- Exhaust air goes back into room rather than to building exterior
- They don't remove heat from room

Conditional Approval

- Regular maintenance by factory approved serviceperson
- Room must be well ventilated
- Operator agrees to remove cooking equipment & hood if Health Dept sees problems
- Sometimes allowed when duct to building exterior is impossible

WOOD-BURNING PIZZA OVENS

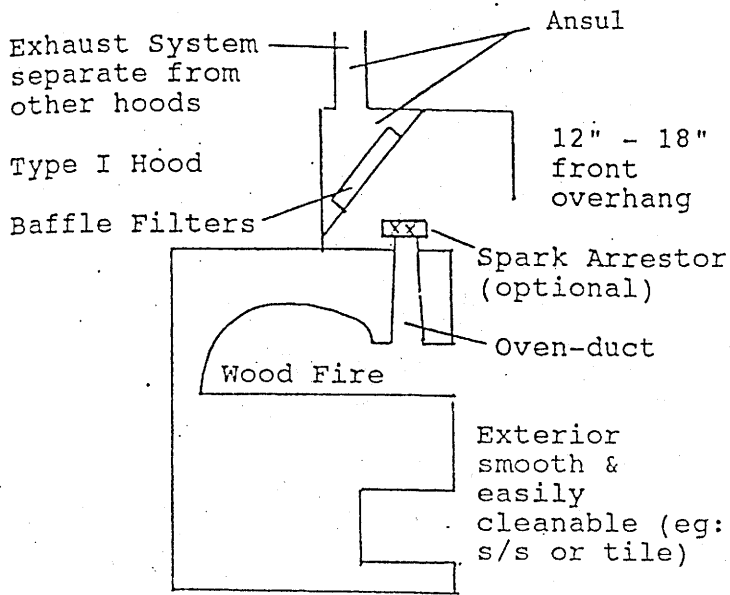

- UMC formula 3  
Q = 75A for 3 sided hood
- Hood overhangs sides of door ≥ 6"
- Distance from top of oven-duct to filter ≥ 12"
- For pizza and bread only

LAW

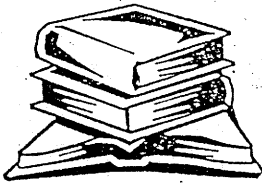

Health Departments have authority to approve or reject hood plans for food facilities  
 CURFFL (Calif. Health & Safety Code) Sections 113915 & 114140

Hoods must pass Health Department performance test  
 Uniform Mechanical Code 508.10 & CURFFL 114140

FRYER NEXT TO OPEN FLAME

NFPA (National Fire Protection Association):

"All deep fat fryers shall be installed with at least a 16-in space between the fryer and surface flames from adjacent cooking equipment."  
 (Section 9-1.2.2 of 1991 Standards)

Sometimes observed is a 16 inch high stainless steel shield welded along the top of one side of the fryer to protect it from adjacent flames.

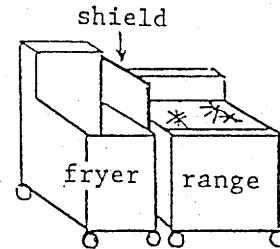

PANTLEG HOOD FOR CONVEYOR DISHWASHER

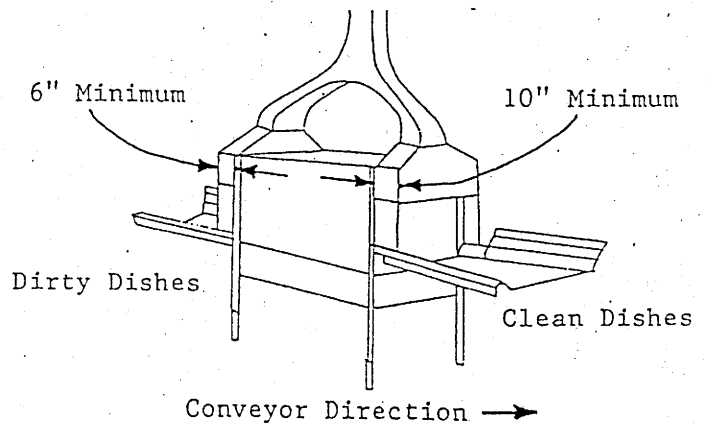

Formula:  
 Dirty Dish End: At least 300 CFM  
 Clean Dish End: At least 500 CFM

ACKNOWLEDGMENTS

*Thanks!*

for valuable assistance:

Alameda County  
Department of Environmental Health:  
Jun Makishima  
Ron Browder  
Don Atkinson-Adams  
Chris Jonas

Industry Consultants:  
Bill George (Westar, Tracy)  
Mark Huckins (JM Campbell, Oakland)  
Eric Guarisco (Captive-Aire)

*Russ Handzus*

---



## INDEX

- Alternate Formula, 19,7,8  
Anemometer, 16
- Backshelf Ventilator Hood, 17  
Back-to-Back Hoods, 7  
BBQ Oven, 17,10
- Cartridge filter (See "Horizontal Slot Filter")  
CCDEH Recommendations for Canopy Hood Type and Formula, 10  
Charbroiler, 19,10,17  
Cleanouts, 5,20  
Clearances for Type I Hood, 6  
Compensating Hoods, 18,4  
Common Duct, 20  
Convection Oven, 17  
Crepe Maker, 10
- Dishwasher Hood, 17,21,10  
Ducts, 4,5,6  
Ductless Hood (See "Ventless Hood")
- Elevations, 2  
Evaporative Cooling, 15  
Exemptions (No Hood), 20,10  
Exhaust Fan, 14,8  
Extralarge Bakery Ovens, 17  
Eyebrow hoods, 17
- Field Testing, 16  
Filters, 12,13,6  
Fire Safety Space (See "Clearances for Type I Hood")  
Four Open-Sided Hood, 19,7,8  
Formulas for Hood CFM, 7,8,10  
Fryer next to open flame, 21
- Griddle, 10  
Grill, 10  
Gyros, 10
- Hood Worksheet, 3  
Horizontal Slot Filter, 18,16  
How to Plan Check Hoods, Inside Front Cover
- Improving Hoods, 19  
Island Hood, 19,7,8
- Laws, 21  
Listed Hoods, 18,7,8,3,16
- Make-Up Air, 15,4,13,16
- NFPA, 21  
Non-Canopy Hood, 17,8
- One Open-Sided Hood, 19  
Oven Hood (Type II), 17  
Oven Overhang (Type I Hood), 17,7
- Pantleg Hood, 21  
Performance Test, 8  
Pizza Oven, 17,8,10
- Q-Factor, 7,8  
Quick Disconnect Gas Line, 11
- Requirements For Hood Plans, Plans and Cut-Sheets, 1  
Sample Elevation, 2  
Hood Worksheet, 3  
Rotisserie, 10
- Side-by-Side Hoods, 20  
Solid Fuel, 7,10  
Split Duct, 20  
Static Pressure, 13
- Two Hoods on Common Duct, 20  
Type I Hood, 4  
Type II Hood, 17,8,13,6
- UL Hoods (See "Listed" Hoods)  
Uniform Mechanical Code, 4-9
- V-Bank Hood, 19  
Ventless Hood, 20
- Wok, 10  
Wood-Burning Pizza Ovens, 21  
Worksheet, 3