



COUNTY OF MENDOCINO
DEPARTMENT OF PLANNING AND BUILDING SERVICES
860 NORTH BUSH STREET • UKIAH • CALIFORNIA • 95482
120 WEST FIR STREET • FT. BRAGG • CALIFORNIA • 95437

IGNACIO GONZALEZ, INTERIM DIRECTOR
JULIA KROG, ASSISTANT DIRECTOR
TELEPHONE: 707-234-6650
FAX: 707-463-5709
FB PHONE: 707-964-5379
FB FAX: 707-961-2427
pbs@mendocinocounty.org
www.mendocinocounty.org/pbs

August 23, 2021

PUBLIC NOTICE OF PENDING ACTION
MENDOCINO HISTORICAL REVIEW BOARD PERMIT

The Mendocino Historical Review Board, at a special meeting to be held on Monday, September 13, 2021, at 2:00 p.m. or as soon thereafter as the item may be heard, will conduct a public hearing on the following project(s) at the time listed or as soon thereafter as the item may be heard. This meeting will be conducted virtually and not available for in person public participation (pursuant to State Executive Order N-29-20). In order to minimize the risk of exposure during this time of emergency, the public may participate digitally or via telecomment in meetings by sending comments to pbscommissions@mendocinocounty.org and is available for viewing on the Mendocino County YouTube page, at <https://www.youtube.com/MendocinoCountyVideo>.

CASE#: MHRB_2021-0013

DATE FILED: 6/23/2021

OWNER: ROBERT MAXON, GLOBE PROPERTIES

APPLICANT: PARTNERS GALLERY LLC

AGENT: PAMELA HAN

REQUEST: Mendocino Historical Review Board request to install a double-faced wood sign hanging perpendicular to the Beacon building front, and dangling from and hung below an existing sign. Sign colors are blue, black, white, and red. Sign copy to read "Partners Gallery." Note: the location is listed in the Mendocino Town Plan Appendix 1 as a Category I Historic Structure, "Beacon Building."

ENVIRONMENTAL DETERMINATION: Categorically Exempt

LOCATION: 45062 Ukiah St, Mendocino; APN 119-233-09.

SUPERVISORIAL DISTRICT: 5

STAFF PLANNER: MARK CLISER

The staff report and notice will be available 10 days before hearing on the Department of Planning and Building Services website at: <https://www.mendocinocounty.org/government/planning-building-services/meeting-agendas/mendocino-historic-review-board>.

As you are an adjacent property owner and/or interested party, your comments are invited. Written comments should be submitted by mail to the Department of Planning and Building Services Commission Staff, at 860 North Bush Street, Ukiah, or 120 West Fir Street, Fort Bragg, California. In order to minimize the risk of exposure during this time of emergency, the public may participate digitally in meetings by sending comments to pbscommissions@mendocinocounty.org by September 12, 2021 or orally via telecomment in lieu of personal attendance. All correspondence should contain reference to the above noted case number. All public comment will be made available to the Board, staff, and the general public as they are received and processed by staff, and can be viewed as attachments to this meeting agenda at <https://www.mendocinocounty.org/government/planning-building-services/meeting-agendas/mendocino-historic-review-board>.

To submit public comments via telecomment, a request form must be received by 7:00 a.m. the morning of the meeting. The telecomment form may be found at: <https://www.mendocinocounty.org/government/planning-building-services/meeting-agendas>.

The decision of the Mendocino Historical Review Board shall be final unless a written appeal is submitted to the Board of Supervisors with a filing fee within 10 calendar days thereafter. If appealed, the decision of the Board of Supervisors to approve the project shall be final. If you would like to be notified of the Mendocino Historical Review Board action, please submit a written request to this office.

If you challenge the above case in court, you may be limited to raising only those issues described in this notice or that you or someone else raised at the public hearing, or in written correspondence delivered to the Mendocino Historical Review Board Secretary at or prior to, the public hearing.

AMERICANS WITH DISABILITIES ACT (ADA) COMPLIANCE. Mendocino County complies with ADA requirements and upon request, will attempt to reasonably accommodate individuals with disabilities by making meeting material available in appropriate alternate formats (pursuant to Government Code Section 54953.2). Anyone requiring reasonable accommodation to participate in the meeting should contact the Department of Planning and Building Services by calling (707) 234-6650 or (707) 964-5379 at least five days prior to the meeting.

Additional information regarding the above noted case may be obtained by calling the Planning and Building Services Department at 964-5379, Monday through Friday.

IGNACIO GONZALEZ, Interim Director of Planning and Building Services



**MENDOCINO HISTORICAL REVIEW BOARD
STAFF REPORT**

**MHRB_2021-0013
SEPTEMBER 13, 2021**

OWNER ROBERT MAXON, GLOBE PROPERTIES
PO BOX 952
EUREKA, CA 95502

APPLICANT: PARTNERS GALLERY LLC
PO BOX 1809
MENDOCINO, CA

AGENT: PAMELA HAN
PO BOX 245
MENDOCINO, CA

PROJECT DESCRIPTION: Mendocino Historical Review Board request to install a double-faced wood sign hanging perpendicular to the Beacon building front, and dangling from and hung below an existing sign. Sign colors are blue, black, white, and red. Sign copy to read "Partners Gallery." Note: the location is listed in the Mendocino Town Plan Appendix 1 as a Category I Historic Structure, "Beacon Building."

STREET ADDRESS: 45062 Ukiah St, Mendocino; APN 119-233-09.

PARCEL SIZE: 12,197± square-feet

ENVIRONMENTAL DETERMINATION: Class 11 categorical exemption for accessory structures such as on-premise signs. Categorically Exempt

HISTORIC STRUCTURES: On Site: Category I - Beacon Building
North: Non-Historic
South: Category IIa – Rego House APN 119-233-01

East: Non-Historic
West: Category I – Beacon Building APN 119-233-08

PAST MHRB PERMITS: 86-35, 89-39, 90-18, 90-19, 91-34, 93-03, 93-09, 94-29, 94-35, 96-25, 97-14, 98-27, 00-52, 2006-12, 2006-19, 2007-02, 2007-23, 2015-03, and 2015-0020.

HISTORIC ORDINANCE STANDARDS: The Mendocino Historical Preservation District Ordinance provides standards for the MHRB to consider when reviewing applications. Relative to this application, the following issues are raised and should be addressed:

Building Size, Height, Proportions and Form	Roof Shape
Relationship of Building Masses and Open Spaces	✓ Color(s)
Relationship to Surrounding Structures	✓ Sign Size
Materials and Textures	✓ Number of Signs
Architectural Details and Style	✓ Placement/Location
Facade Treatment	Lighting
Proportions of Windows and Doors	Paving/Grading
Landscaping	

APPLICABLE SECTIONS OF MENDOCINO TOWN ZONING CODE: Chapter 20.712.015 *Sign Standards*, Section 20.760.050 *Standards*, and Section 20.760.030(F).

APPLICABLE SECTIONS OF MHRB GUIDELINES: Signs, page 10.

APPLICANT'S STATEMENT: "Replace previously approved Honey & Ro sign with Partner's Gallery sign. Same dimensions and placement as previous sign hanging from the Mendocino Beacon sign. Painted wood and two sided."

RECOMMENDED FINDINGS: The Review Board shall not approve or conditionally approve any application for proposed work unless it affirmatively makes the following findings:

- (a) The exterior appearance and design of the proposed sign is in harmony with the exterior appearance and design of the existing structures within the District and with that of existing subject structure; and
- (b) The appearance of the proposed sign will not detract from the appearance of other property within the District.

RECOMMENDED CONDITIONS:

1. This action shall become final and effective on the 11th day following the decision unless an appeal is filed pursuant to Section 20.760.072 of the Mendocino County Code. The permit shall expire and become null and void at the expiration of two years after the effective date except where construction and or use of the property in reliance on such permit has been completed prior to its expiration.
2. The application along with supplemental exhibits and related material shall be considered elements of this permit, and compliance therewith is mandatory.
3. This permit shall be subject to the securing of all necessary permits for the proposed development from County, State and Federal agencies having jurisdiction. The applicant shall secure all required building permits for the proposed project as required by the Building Inspection Division.
4. This permit shall be subject to revocation or modification upon a finding of any one (1) or more of the following:
 - a. That such permit was obtained or extended by fraud.
 - b. That one or more of the conditions upon which such permit was granted have been violated.
 - c. A final judgment of a court of competent jurisdiction has declared one (1) or more conditions to be void or ineffective, or has enjoined or otherwise prohibited the enforcement or operation of one (1) or more such conditions.
5. This permit for this sign is valid only for as long as this business is conducted at this location. The Review Board reserves the right to consider all aspects of any future changes to the sign, including size.
6. A sign copy exemption, pursuant with MCC Sec. 20.760.040(H), can be applied once to the subsequent business at this location.
7. Sign copy shall not include telephone numbers, web addresses, references to social medial, or other similar information

The Review Board's action and this permit will not be final and effective and work may not commence on the project until after a ten day appeal period has ended. You will be notified if a timely appeal is filed.

Appeal Fee: \$1,616.00 (Check payable to County of Mendocino).

Appeal Period: Appeals must be received within 10 days of Review Board Action.

ATTACHMENTS:

- A. Application MHRB 2021-0013
- B. APN: 119-233-08 (Severko)

<p>COUNTY OF MENDOCINO DEPT. OF PLANNING & BUILDING SERVICES</p> <p>120 WEST FIR STREET FORT BRAGG, CA 95437 Telephone: 707-964-5379 Fax: 707-961-2427</p>	<p>Case No(s) <u>MHRB-2021-0013</u></p> <p>Date Filed <u>6/23/21</u></p> <p>Fee \$ <u>\$ 718.78</u></p> <p>Receipt No. <u>PRJ-042939</u></p> <p>Received by <u>Tia Sar</u></p> <p style="text-align: right;"><u>Office Use Only</u></p>
--	---

MHRB APPLICATION FORM

Name of Applicant <i>PARTNER'S Gallery</i>	Name of Property Owner(s) <i>Robert Maxon Globe Properties</i>	Name of Agent <i>Pamela Hahn</i>
Mailing Address <i>Box 1809 Mendocino</i>	Mailing Address <i>Box 952</i> <i>423 First St. Eureka CA 95502-0952</i>	Mailing Address <i>Box 245 Mendocino</i>
Telephone Number <i>707 328 7597</i>	Telephone Number <i>707 499 8339</i>	Telephone Number <i>707 328 7597</i>
Assessor's Parcel Number(s) <i>119 - 233 - 09</i>		
Parcel Size <input type="checkbox"/> Square Feet <input type="checkbox"/> Acres	Street Address of Project <i>45062 Ukiah St. Mendocino</i>	

TYPE OF DEVELOPMENT
(Check appropriate boxes)

- Demolition. Please indicate the type and extent of demolition. (see next page)
- Construction of a structure.
- Addition to a structure.
- Alteration of exterior of structure.
- Construction, installation, relocation or alteration of outdoor advertising sign.
- Outdoor lighting.
- Walkways, driveways, parking areas, and grading.
- Exterior painting of a structure.
- Other.

- C - Commercial
- FL - Forestland
- MU - Mixed Use
- RM - Multiple Family Residential
- OS - Open Space
- PF - Public Facilities
- RR1 - Rural Residential (1 acre minimum)
- RR2 - Rural Residential (2 acre minimum)
- RR2.PD - Rural Residential (Planned Development)
- SR - Suburban Residential
- R+ - Mendocino Town Residential

- Legend**
- * Visitor Serving Facilities
 - #B Bed & Breakfasts
 - Land Use Classes
 - Assessors Parcels

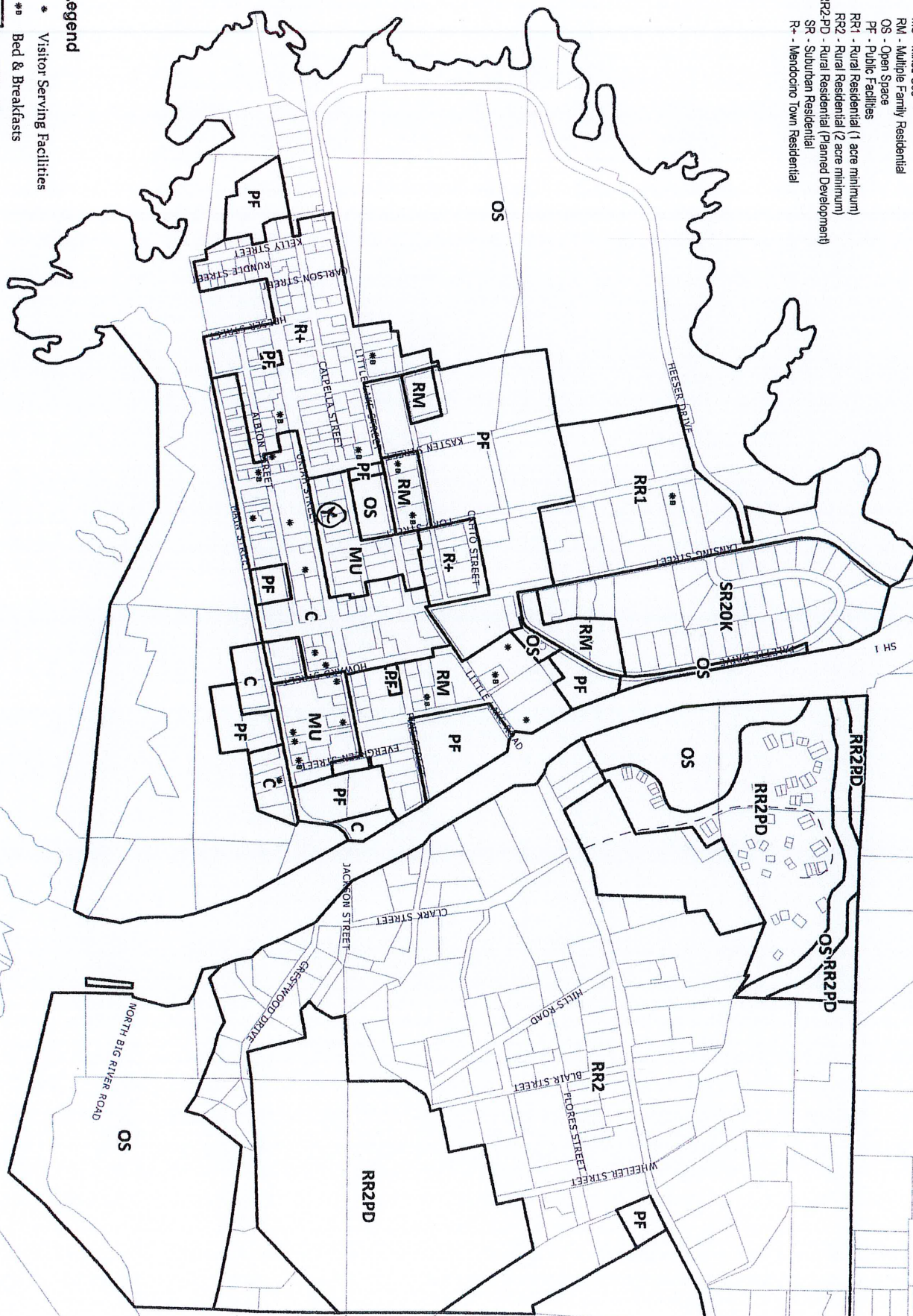
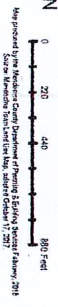

MENDOCINO TOWN LAND USE

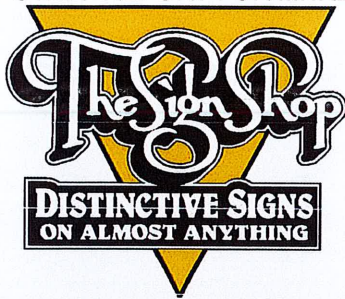

43197 Road 409
Mendocino

phone.. 707-964-0608
fax..

rick@mendosign.com
cont. lic.527921



Replace previously approved Honey and Ro sign with this sign. Same dimensions and placement as previous sign, hanging from the Mendocino Beacon sign, Painted wood and two sided.



This is an original unpublished drawing created by THE SIGN SHOP. It is submitted for your personal use in conjunction with a project being planned for you. It is not to be shown to anyone outside your organization, nor is it to be reproduced, copied, or exhibited in any fashion without expressed written permission from THE SIGN SHOP. Right to use designs for anything other than the subject sign is a violation of copyright laws.

The design rights are sold separately for other uses.

From: Carol carol@dominy.com
Subject: Partners Gallery
Date: June 21, 2021 at 4:05 PM
To: pdhahn@mcn.org

Hi, Pamela,

Karen McGrath asked me to send documentation of the Kelley House board decision on your sign.

Best Wishes for your new gallery,
Carol Dominy



KELLEY HOUSE MUSEUM
www.kelleyhousemuseum.org

40717 Apollo Street
P.O. Box 222
Menlo Park, CA 94026

June 21, 2021

Pamela Hahn
pdhahn@mcn.org

Dear Pamela:

On June 17, 2021, the Kelley House Board of Directors reviewed the images you provided for the Partners Gallery sign and had no objections, pursuant to the Facade Easement we hold in perpetuity on the south elevation of the historic Beacon Building.

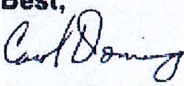
Best,

Carol Dominy

Board of Directors

Sarah Nafhe
President

Carol Dominy
Vice President

Ian Roth
Treasurer

Megan Coddington Smith
Board Member

Jane Tillis
Board Member

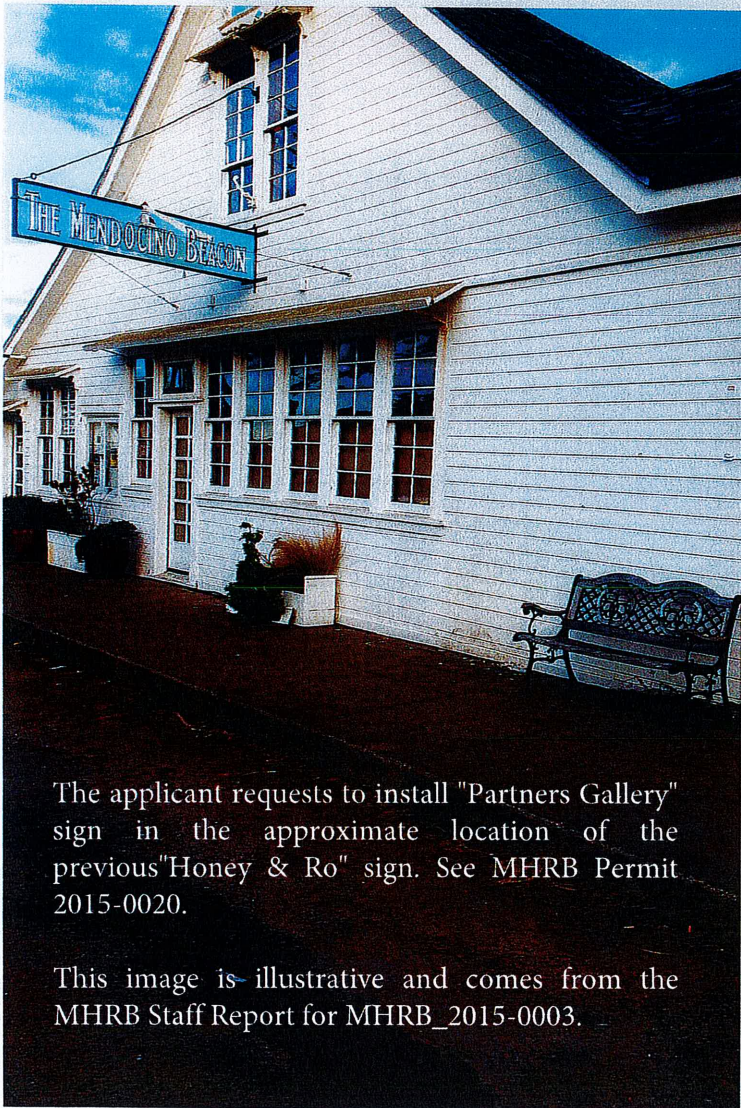

The applicant requests to install "Partners Gallery" sign in the approximate location of the previous "Honey & Ro" sign. See MHRB Permit 2015-0020.

This image is illustrative and comes from the MHRB Staff Report for MHRB_2015-0003.

BEACON BUILDING, 1872
45064 Ukiah Street

Sverko, March 22, 1999
APN: 119-233-09
MHR: #62, Landmark No. I
119-233-08 is a vacant lot

This building was surveyed by
Stebbins/Bear dba MHR Inc.,
In May, 1976.

Wm. Heeser built this building
following the disastrous fire
of 1870, which destroyed his
store business building on
Heeser St. at Main Street.

It originally was a bank building,
housing the Mendocino Bank of
Commerce and the bank of
Mendocino.

The first Mendocino newspaper
was the Mendocino Dispatch,
published by Matt Lynch from
the 1860's until 1873, when he
moved to Ukiah. He was
followed by M. J. C. Galvin who
launched the "West Coast Star"
in 1874. In 1877, Galvin sold
out to Wm. Heeser, and the first
Mendocino Beacon was issued
Oct. 6, 1877, and has been a
weekly publication continuously
since that time, with never an
issue missed.

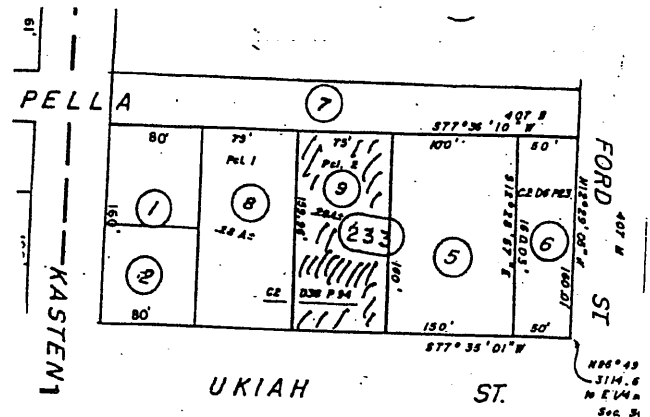

Oct. 6, 1877, Heeser added to the building on the west side.

Nov. 20, 1909, the Beacon and express office building has been raised and a new foundation placed under it. L Fred Smith is also laying a cement walk in front of the building this week.

Wm. Heeser son, August Heeser inherited the business and property in 1906, and operated it until his death in 1966. It was sold by his heir, Alfred A. Nichols in June 1976 to Biage Quattrocchi, who moved the publishing office to the west side of the building and operated an antique store in the main building.

119-233-09 con't

Quattrocchi, Dec. 28, 1976 **dedicated the front facade conservation easement to Mendocino Historical Research, Inc. in perpetuity, recorded Dec. 30, 1976, Bk 1069, Pg 525, #37349.**

In November 1972, a building permit was issued for remodeling, \$3,000.

The newspaper itself was acquired by Mendocino Publishing Company who later sold to Donrey Publications, who currently own the Fort Bragg Advocate News, the Ukiah Daily Journal and the Mendocino Beacon.

4/4/1977, Biage Quattrocchi appl to MHRB to add eleven skylights and construct a balcony deck at the rear of the building (north side). App'd.

December, 1976, Don & Lee Burleson moved their art gallery into the east side of the building. In 1981, a foyer addition to the east side for the gallery, accessed by brick patio was presented.

The Main Center commercial space of this building houses an old and historic walk in vault undoubtedly put in by Wm. Heeser before the turn of this century and while it was being used as a bank, which should be historically protected by all future owners.

An office was also created in the upstairs, currently the office of Alan Cone.

Since the death of Don Bruce, 1997, I don't know who the current owners are, or if it is still Beacon Assoc's.

The Beacon building has housed various businesses since 1977.

Jan. 1986

TOWN OF MENDOCINO, Facade architectural easements
granted to Mendocino Historical Research, Inc.

- #1: Beacon Building - 1872 - APN: 119-233-09 45064 Ukiah Street
Front, south facing, facade granted to Mendocino Historical
Research, Dec. 28, 1976 by Biage & June T. Quattrocchi
Recorded by County Recorder, Dec. 30, 1976, Book 1069,
pg 525, #37349.
Facade easement granted in perpetuity.
- #2: replaced by #3.
- #3: Jarvis-Nichols Building, c1871, 45080 Main Street
APN: 119-238-01
"all portions and facades of the Jarvis-Nichols Building
fronting upon Main Street, Mendocino" (south facing facade)
granted by Lois B. & Robert L. Raymond, in perpetuity to
Mendocino Historical Research, Inc., Sept. 13, 1978 and
recorded by County Recorder, Dec. 8, 1978, Book 1183,
page 741, #25933.
- #4: Cavanaugh House, c 1860, 44801 Main Street APN: 119-250-29
North and west facades granted to Mendocino Historical
Research, Inc., for thirty years from Dec. 3, 1979, by
Gary F. & Lana Ojendyk ... and re corded by County
Recorder, Dec. 10, 1979, Book 1240, Page 64, #22593.
- #5: MacCallum House, 1882/1908 45020 Albion St. APN: 119-236-10
"frontal portion of the building" granted by William J. Norris
and Susan Norris, in perpetuity, on Jan. 3, 1980 and
recorded by County Recorder on Jan. 11, 1980, Book 1243,
page 518, # 603.
- #6: Red Baptist Church Building, 1897, 45015 Ukiah St. APN 119-236-11
"frontal portion of the building" granted by William F. Norris
and Susan J. Norris Jan. 3, 1980, and recorded by County
Recorder Jan. 11, 1980, Bood 1243, pg 521 #604. "in perpetuity"

Town of Mendocino, Facade architectural easements
granted to Mendocino Historical Research, Inc.
page two - Jan. 30, 1986

#7: Bettencourt House, c1887 45320 Ukiah St. APN: 119-215-01
"all facades of the outbuilding located on the property"
granted by Jason Trent & Carol Trent, in perpetuity,
to Mendocino Historical Research, Inc., Dec. 23, 1980
and recorded in county records Dec. 26, 1980, Book 1287,
page 433, #19983. "Outbuilding" described as a tank
house and underlying workshop.

#8: Gregory House, 1875, 45132 Ukiah St. APN: 119-232-06
"frontal facade of the building" granted by J. Julian
Bartee and Marie L. Bartee, in perpetuity to Mendocino
Historical Research, Inc.. on Sept. 15, 1981 and
recorded in County records: Book 1324, pg 477, Oct. 1, 1981,
#15160.

#62

ATTACHMENT B
119-233-09

State of California - The Resources Agency
DEPARTMENT OF PARKS AND RECREATION

1. County MHRB 2021-0013
PAGE B-5
Site Sent to State May 1976
(State Use Only)

HISTORIC RESOURCES INVENTORY

- 2. Common Name Mendocino Beacon
- 3. Location 45066 Ukiah St.
- 4. Date of Inventory June 1975
- 5. Status: Occupied Unoccupied Preservation Work in Progress
- 6. Accessible to Public: Yes, Restricted Yes, Unrestricted Not Accessible to Public
- 7. Owner of Property: Name F.A. Nichols Address PO Box 605
City Mendocino State CA Zip 95460 Phone 937-5874
- 8. Approximate Acreage 1+ acre or Approximate Lot Size _____
- 9. Representation in existing historic or prehistoric survey (see instructions): Yes No Unknown
Name of Survey Mendocino Historical Research, Inc.
- 10. Depository for Records: Name Mendocino Historical Research, Inc.
Address PO Box 922 City Mendocino State CA Unknown
- 11. Representation on current Historic Landmark Registry programs: Yes No Unknown
Which Program _____
- 12. Description (multiple choice): Altered Unaltered Condition: Excellent Good Fair
Deteriorated Ruins Unexposed (archeological site)
- 13. Briefly describe the present and original physical appearance of site or structure and note any major alterations:
The Mendocino Beacon is a large wood frame structure with a rather unique toboggan slide roof. The building was first used as a bank, the bank's vault is still in the building. The building has not been significantly altered since its construction.
- 14. Event of Historical Importance: None Local State National Describe briefly (see instructions for architectural exceptions): _____
- 15. Person of historical importance: Name William Heeser
Local State National Unknown None
- 16. Statement of Significance: In 1870 William Heeser, and others, organized the Bank of Mendocino and constructed the Beacon building to house it. In 1877 William Heeser established The Mendocino Beacon and used the structure for the newspaper's office, and presses. The newspaper has been published here for 98 years now.
- 17. Documents and Books (bibliography): Records in files of the Mendocino Historical Research, Inc.
- 18. Photographs included of site or structure: Yes No (see instructions)

27. County

1 2
(State Use Only)

28. Site

3 4 5 6 7

HISTORIC RESOURCES INVENTORY
Key Information

This page of the form is designed for computer programming of key information. There will be some duplication of material from the first page.

29. Historic Name
M E N D O C I N O B E A C O N

30. City, town or rural postal area
M E N D O C I N O C A

Card Number
1
80

31. Street or rural address
4 5 0 6 6 U K I A H S T

32. Public Ownership (Agency)

33. Private Ownership

34. Item of Interest
Site Object Structure

35. Type
Historic Prehistoric

36. Period
Month Year to Month Year
1870 to 07 1975

Numbers 37 - 39 are for State Use Only.

37. Geographic Coordinates
Latitude Longitude

38. Era
Indian Hispanic American

Card Number
2
80

39. Interpretation

Theme

Subtheme

Element

Subelement

HISTORIC RESOURCES INVENTORY
Architectural Supplement

Mark the answer sheet for this section in the same way that you marked answers to questions 29 – 36, placing one number per block. As this section will be computerized for storage and retrieval of information, please make your numbers clear and legible. Disregard the small numbers under each answer bracket; they are for keypunch reference.

Card 4

- 40. Placement 01
10 11
- 41. Plan 02
12 13
- 42. Stories 07
14 15
- 43. Basement 01
16 17
- 44. Foundation 06
18 19
- 45. Exterior Walls - Wood 07, , ,
20 21 22 23 24 25 26 27
- 46. Exterior Walls - Stone 01, , ,
28 29 30 31 32 33 34 35
- 47. Exterior Walls - Adobe, Other Earth 01, , ,
36 37 38 39 40 41 42 43
- 48. Exterior Walls - Brick, Composition, Tile 01, , ,
44 45 46 47 48 49 50 51
- 49. Exterior Walls - Coursing 01, , ,
52 53 54 55 56 57 58 59
- 50. Exterior Walls - Concrete 01, , ,
60 61 62 63 64 65 66 67
- 51. Exterior Walls - Metal, Glass 01, , ,
71 72 73 74 75 76 77 78

Card 5

- 52. Exterior Sheathing 01, , ,
10 11 12 13 14 15 16 17
- 53. Wall Design 07, , ,
18 19 20 21 22 23 24 25
- 54. Roof Shape 05, 42, ,
26 27 28 29 30 31 32 33
- 55. Roof Material 08, , ,
34 35 36 37 38 39 40 41
- 56. Chimneys 04
42 43
- 57. Chimney Material 04, , ,
44 45 46 47 48 49 50 51
- 58. Dormer Shape 04, , ,
52 53 54 55 56 57 58 59
- 59. Roof Trim - Eaves 04
60 61
- 60. Roof Trim - Gable End 06, , ,
62 63 64 65 66 67 68 69
- 61. Roof Trim - Special Features 11
70 71
- 62. Window Location 04
72 73
- 63. Window Opening Shape 03
74 75
- 64. Window Top Surrounding Detail 03
76 77
- 65. Window Sides Surrounding Detail 03
78 79

Card 6

- 66. Window Bottom Surrounding Detail 04
10 11

- 67. Window Division 04
12 13
- 68. Window Movement 03
14 15
- 69A. Window Panes - Upper or Left 08
16 17
- 69B. Window Panes - Lower or right 08
18 19
- 70. Special Window Shapes 01, , ,
20 21 22 23 24 25 26 27
- 71. Special Window Types 01, , ,
28 29 30 31 32 33 34 35
- 72. Main Door Location 04
36 37
- 73. Main Door Opening 03
38 39
- 74. Main Door Top Surrounding Detail 03
40 41
- 75. Main Door Sides Surrounding Detail 03
42 43
- 76. Main Doorway Type 03
44 45
- 77. Main Doorway Side Panels 01
46 47
- 78. Main Doorway Transom Panels 04
48 49
- 79A. Main Door Type 03
50 51
- 79B. Main Door Type 09, , ,
52 53 54 55 56 57 58 59
- 80. Main Door Material 03, , ,
60 61 62 63 64 65 66 67
- 81. Main Door Glazing 01
68 69
- 82. Stairs, Location and Design 01
70 71

Card 7

- 83. Stairs, Shape 01
10 11
- 84. Main Porch 01
12 13
- 85. Porch Supports 01
14 15
- 86. Porch Supports Material 01, , ,
16 17 18 19 20 21 22 23
- 87. Porch Height 01
24 25
- 88. Additional Building Features 01, , ,
26 27 28 29 30 31 32 33
- 89. Ornamentation 06, 07, ,
34 35 36 37 38 39 40 41
- 90. Property Features 01, ,
42 43 44 45 46 47 48 49

PN 145-223-00

19. Sketch map:

In the space below, draw a sketch map showing the location of the site or structure being inventoried. Label streets and roads and show the distance from the nearest major intersection. Add an arrow to show north on the map. As a rule, show north to the top of the page.

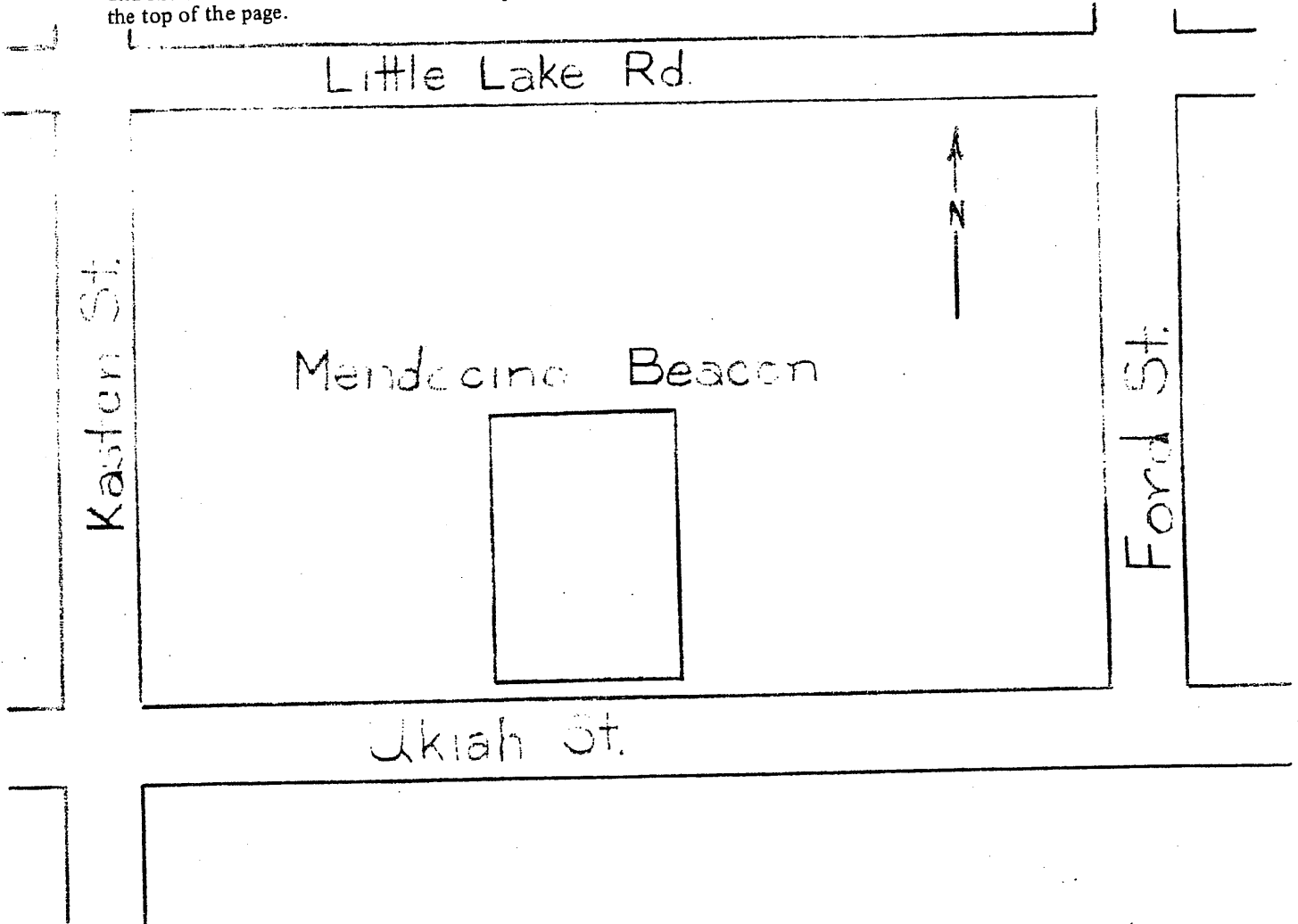

20. Form prepared by: Name Michael MacDonald Address P.O. Box 922
 City Mendocino Phone 937-8440 Organization M.H.R.

THE FOLLOWING (21-26) ARE FOR STRUCTURES ONLY.

21. Date of Construction 1870 Factual Estimated Unknown
 Architect Unknown Builder Unknown

22. Basic historic use of structure (see instructions): 5b - First used as a bank from 1870-1877, then 9c - Newspaper printing facility

23. Basic present use of structure (see instructions): 9c Newspaper office, and printing facility

24. Is structure on original site? Yes No Unknown

25. Present Environment and Threat of Destruction (see instructions)
 Secure Threatened Unknown

26. Area of structure at ground level: Width 51' Length 68' Unknown

10-13-1977

tor

trunk from a cab, there might have been some suspense. But we are sure that Candida will not abandon her comfortably upholstered pedestal.

Val Beaumont
MENDOCINO

Reading the "Critic's Box" review of "Candida" in the Beacon of 6 October I was amazed to discover that the play starred a Victorian set, lace curtains and an Oliver typewriter c. 1900.

Perhaps it is normal for a Box to respond affirmatively to inanimate objects, but be that as it may, the Box certainly saw fit to give almost every one of the live players a nearly terminal haircut.

It seems to me that an encouraging word should be said about these live Little People behind and on the fringe of the production.

First, George Bernard Shaw (the writer): True, he wrote words and lots of them. The Box suggests that Bob Avery as Morell should not have said them. But it would be odd indeed if Avery did not say them. Consider, what would the set, the curtains and the typewriter have done with naught but a profound silence?

It is true that saying a lot of words on stage is, at best, a difficult matter—even if they are written on your cuff. Avery's courage is prodigious. And you could hear

every one of those words. Another Little Person, supporting player Sandra Hahn as Candida, did just fine. (I hate to agree with the Box on this but fair is fair.) She lent enormous help to the set and the curtains, moving effectively and graciously in and out. She had little to do with the typewriter, however. This is not to be construed as criticism: The typewriter was none of her business.

Tonna Kutner functioned as two Little People: She designed the handsome costumes and saw to their execution on a minimal budget. (The Box did not see fit to credit this.) She played Morell's secretary, Prossie, as well. The Box mentioned that she needed to "develop spacing." I take this to be a complaint about her typing.

Why Kutner, an otherwise excellent actress, acting excellently, should be faulted for inadequate clerical skills escapes me. Her action upon the 1900 Oliver struck me as most creative, although it may be just as well that the audience was not required to read the typescript.

Bit player Bob Cohen as Marchbanks (apparently perceived by the Box as some sort of turkey) "roasted in his love for Candida" with high energy and intelligence it seemed to me.

Little Burt Tepfer played with like wit, and seemed to be able to move all his joints, although the Box implied that he may be made of wood.

Then there was Candida's Dad, Warren Peters (the little Dicken!) playing

robustly and delightfully as though he were a real part of the cast and not an escapee from the Pickwick Papers.

Even the star of the production, the set, well known for its self-importance, paid tribute to one of the Little People, albeit reluctantly. It was heard to mutter, "I owe most of my considerable success to my designer, Matthew Roland."

The lace curtains blushing admitted to being contemporary Sears, but the typewriter proudly proclaimed its authenticity. The clatter of its keys and its resounding bell substantiates this. These, among many other items, were rounded up by Little Person Margo Farrar as stage manager.

Probably the Tiniest Person of all, director Don Murray, had little to do but still deserves applause. His only chore (which he performed skillfully) was to put together an enormously complex play, make sure that these complexities were both intelligible and entertaining, and to keep an eye out to see that the bit players moved around the set without colliding. Even the set admitted, "At least they didn't knock into me."

Finally, there is Wee MPAC (Mendocino Performing Arts Company) which is behind this production, as, indeed, it has been behind a continuous series of live performances. MPAC is a non-profit organization that must be either mad or dedicated to go on like this.

Well, there's always television, Box. And good luck with that!

Fran Moyer
MENDOCINO

Since the Mendocino Beacon was actually the third newspaper to be published in Mendocino, perhaps its centennial should not go by without a mention of how the Beacon came to be, at least as August Heeser explained it to me.

Mat Lynch had started the Mendocino Dispatch at Mendocino in the middle 1860's. In the early seventies, Lynch

decided that there was little or no future in Mendocino, but there would be a future in Ukiah, so he moved the Dispatch there in 1873.

This left Mendocino (and the coast) without the sure sign of an up and coming community, which upset the local businessmen. William Heeser was concerned enough to back James Galvin financially in his proposal to start a new paper, and Galvin launched the West Coast Star early in 1874.

The Star had a successful start, but as time went on, the business went down hill, and Galvin finally failed in the spring of 1877 and the paper was discontinued. This not only left Mendocino again without a newspaper, but also left William Heeser with nothing to show for his investment but a set of printing equipment.

The only way to salvage his investment was to start another newspaper, something which he believed the community required, and this he arranged to do.

To manage the business for him, he brought in Meacham from somewhere below. This did not work out satisfactorily, so Meacham eventually left, and from then on William Heeser assumed full responsibility for the Beacon.

Incidentally, August Heeser took pleasure in the fact that he was six months older than the Beacon.

Richard H. Tooker
SAN FRANCISCO.

119-233-09
Beacon Bldg
MHR # 67

COPY OF LETTER TO Mendocino County Board of Supervisors:

As a San Francisco resident and loving, appreciative visitor to the town of Mendocino during the past 10 years, I now feel compelled to write this letter.

It has festered in my mind for over a year, and the recent issue of street vendors in Mendocino Village has provided the "final straw" that provokes action.

This is a letter of concern for the quality of the historical, cultural, and physical life

Continued to page 5

NOYO REALTY

1080 South Main Ft. Bragg 964-5069

WINN BAUMGARTNER [Broker]

NEW HEXAGON 3 bedroom, 2 bath house under construction. Just off Little Lake Rd. only 1/4 mi. from school in Mendocino. Beautiful wooded 3 1/2 acres. With a 10 gal. per minute well. \$59,500

119-233-09
A 974 24 MHR

MENDOCINO COAST FIDELACON

A COAST PAPER FOR COAST PEOPLE SINCE 1877

PUBLISHED WEDNESDAY - FRIDAY

15 Cents

Vol. C No. XXXVII

Mendocino, Mendocino County, California

Wednesday, January 12, 1977

Facade Donated To Community

MENDOCINO—"It's the last-
ed 105 years. I'd like to see it
owner Biage Quattrocchi
says of the Beacon Building
on Ukiah Street.
Quattrocchi recently don-
ated the facade of the
landmark building to Men-
cino Historical Research,
Inc., in perpetuity.

MENDOCINO

"No matter what happens,
we know it will always be
here," he said last week.
The federal Tax Reform
Act of 1976 allows owners of
commercial historic build-
ings, including rentals, to
make a one-time charitable
income tax deduction on a
grant facade easement.
Quattrocchi is the first in
town, and one of the few in
northern California, to take
advantage of the tax break.
"I learned about it (the
Tax Reform Act) about a year
ago and I thought, 'What a
great way to help me and to
help the building stay the

way it is."
"It has its own kind of
beauty. It's not beautiful in
the sense of the ginger-
bread and that kind of thing,
but I think it is a very
beautiful building."
"I like its somewhat unu-
sual shape. And it's a very
well-built old building, too,
built of virgin redwood with
large timbers and boards 18
to 24 inches wide which you
can't get today."
The grant means Beacon
Building owners cannot do
anything to the face of the
building without approval of
MHR.
MHR is willing to accept
other easements in town,
president Beth Stebbins said
Friday.

casement only until June 1,
1977.
"We think maybe some
other people in town would
like to take advantage of the
grant facade easement," she
said. MHR thinks a great
many buildings in the histo-
ric district might be eligible.
"It can be any commercial
facade that is historically
authentic," Stebbins said.
Though the Beacon Build-
ing face has been altered, it
is only because of repairs,
she said.
William Heeser had it built
in 1872 after his general
merchandise store on the
corner of Heeser and Main
burned in 1870. MHR be-
lieves.

The bricks are soft, fired in
a regular fire, Quattrocchi
says. They are stuck together
with lime rather than with
regular cement.
The vault, a main attrac-
tion to visitors of the build-
ing, is 18 inches thick on four
sides, with an air space in
between layers for fireproof-
ing.
"I can't believe how se-
cure it would be," Quattroc-
chi wonders. "The bricks
were so soft somebody prob-
ably could get in with a small
chisel."
The beautifully decorated
vault door was made in
Cincinnati and probably
brought around the Horn, he
said.

Aside from newspaper
publishing, Heeser also was
agent for Wells Fargo, which
transported passengers and
freight. The old Wells Fargo
safe is still in use in the
Mendocino Coast Beacon of-
fice on the west side of the
Beacon Building.
The building remained in
the Heeser family until June
1976, when Quattrocchi
bought it from Francis A.
Nichols, former Beacon pub-
lisher.
Quattrocchi and his wife
Bonney and son Mark have
been carefully restoring and
remodeling the structure

ever since.
Last fall the newspaper
office moved from the center
section to the west side.
Gallery Mendocino recently
occupied the east side of the
building.
Quattrocchi is now at work
on the center section, which
will become his American
antique shop. He hopes to be
ready to open near the end of
February.
A professional office space
will be available for rent
upstairs.
A new west side front door
and small-paned windows
have been installed on the
front of the building, and a
new center door will go in,
with MHR's approval.

According to MHR, the
building once had a vertical
board front, but Jim O'Donnell
was hired to cover it with
horizontal boards because
the old ones leaked.
O'Donnell also put up the
decorated date in the gable
made from the headboard of
a bedstead he found.

In the event MHR dis-
solves, Quattrocchi's ease-
ment will be transferred to
the National Trust for Histor-
ic Preservation. The one-
time charitable deduction
does not apply to property
taxes.

The exposed brick vault
wall now can be seen from
Don and Lee Burtleson's
relocated "Mendocino Gal-
lery" on the east side of the
Beacon Building.
In October 1877 Heeser
and W. H. Mescham estab-
lished the Mendocino Bea-
con. Heeser became sole
proprietor a year later.
The Beacon was Men-
do-

along with the Bank of
Mendocino. At one point
there were two banks in the
building on the east side
where the brick vault is.
In his remodeling of the
interior, Quattrocchi has
sandedblasted to expose those
bricks, which were made
locally by one of several
brickmakers then in the area.

The law requires a 30-year
minimum easement. Each
individual making the grant
with the help of appraisers,
would have to decide on the
value of the facade, she said.
However appraisers are not
experienced in this type of
evaluation, she warned.
"As the law now stands, it is
possible to make such an

has
in a
if an
in a
ited
tical
the
I he
the
dge
son
by



Heeser moved his store in along with the Bank of Mendocino. At one point there were two banks in the building on the east side where the brick vault is. In his remodeling of the interior, Quattrocchi has sandblasted to expose those bricks, which were made locally by one of several brickmakers then in the area.

The exposed brick vault wall now can be seen from Don and Lee Burleson's relocated "Mendocino Gallery" on the east side of the Beacon Building.

In October 1877 Heeser and W. H. Meacham established the Mendocino Beacon. Heeser became sole proprietor a year later. The Beacon was Mendocino's first newspaper.

According to MHR, the building once had a vertical board front, but Jim O'Donnel was hired to cover it with horizontal boards because the old ones leaked. O'Donell also put up the decorated date in the gable made from the headboard of a bedstead he found.

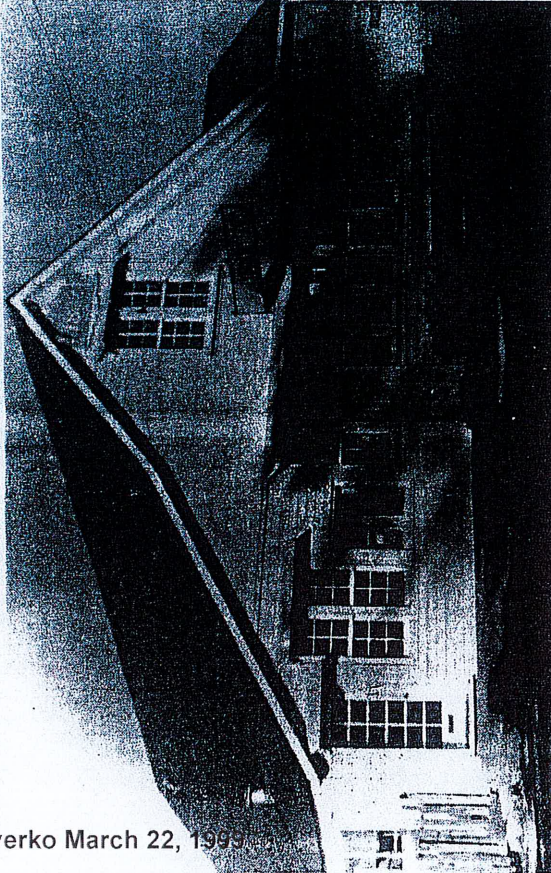

erko March 22, 1993

Tax Incentive for Preservation

MENDOCINO—The federal Tax Reform Act of 1976, signed into law last October, provides a number of tax incentives to encourage preservation of historic structures.

It also changes provisions in the income tax code that have worked against preservation.

The law defines certified historic structures as those which have commercial characteristics that can be depreciated (residential property if it is rented) listed in the National Register, or located in an historic district such as Mendocino.

The law addresses amortization of rehabilitation costs, demolition, depreciation of improvements, substantially rehabilitated property and transfers of partial interests

in property for conservation purposes.

Amortization of Rehabilitation Expenditures. A taxpayer may amortize over a 60-month period any capital expenditure made in a certified rehabilitation of a certified historic structure, in lieu of depreciation deductions otherwise allowed.

To take advantage of this provision, expenditures must occur before June 15, 1981. The effect of this section is to encourage owners to rehabilitate their historic commercial properties because of substantial tax savings in a short period of time.

Previously, an owner was required to spread tax deductions over the life of the property.

Demolition. An owner or

Cont. to Page 2

from federal income taxes. "Nobody makes any money on these old buildings," Quattrocchi said last week. So when he learned of the new law, he thought it was a neat way to help the business person as well as preserve an historic structure.

[Coast Beacon Photo]

BEACON FACE DONATED—Blage and Bonney Quattrocchi, owners of the landmark Beacon Building on Ulmah Street, Mendocino, hope it's around for another 100 years. As a good first step, they recently donated the facade to Mendocino Historical Research, Inc. New federal law allows grant facade easements on historic commercial property to be deducted

<p>TO</p> <ul style="list-style-type: none"> ● DALPHINA D. HERVILLA ● P. O. Box 1261 ● Mendocino, Ca 95460 937-5564 	<p>FROM</p> <p>MENDOCINO HISTORICAL REVIEW BOARD P. O. Box 744 Mendocino, California 95460 /</p> <p>APPL.# <u>85-03</u> Date: <u>1 / 7 / 85</u></p>
<p>AF# 119-233-04 Street No. 45064 Ukiah St. (Beacon bldg)</p>	
<p>REQUEST: SIGN: 6" x 30" redwood "DALPHINA'S"</p>	
<p>BOARD ACTION 1/7/85: MOTION, Jones/O'Brien and unanimously carried to continue to Feb. 4, 1985 when hopefully the applicant can be here to answer questions as to why the signs are necessary.</p>	
<p>Approved by: _____ chairman</p>	

<p>TO</p> <ul style="list-style-type: none"> • Dolores Spath • P. O. Box 57 • Mendocino, Ca 95460 937-1234 	<p>FROM</p> <p>MENDOCINO HISTORICAL REVIEW BOARD P. O. Box 744 Mendocino, California 95460 /</p> <p>APPL.# 85-02</p> <p>Date: 1 / 7 / 85</p>
<p>AP# 119-233-04 Street No. 45062 Ukiah (Beacon bldg)</p>	
<p>REQUEST: SIGN: 6" x 30" redwood "PANACHE"</p>	
<p>BOARD ACTION 1/7/85: MOTION, Jones/O'Brien and unanimously carried to continue to Feb. 4, 1985 when hopefully the applicant can be here to answer questions as to why the signs are necessary.</p>	
<p>Approved by: chairman</p>	

<p>TO</p> <ul style="list-style-type: none"> ● DALPHINA D. HERVILLA ● P. O. Box 1261 ● Mendocino, Ca 95460 937-5564 	<p>FROM</p> <p>MENDOCINO HISTORICAL REVIEW BOARD P. O. Box 744 Mendocino, California 95460 /</p> <p>APPL.# <u>85-03</u></p> <p>Date: <u>1 / 7 / 85</u></p>
<p>AP# 119-233-04 Street No. 45064 Ukiah St. (Beacon bldg)</p>	
<p>REQUEST: SIGN: 6" x 30" redwood "DALPHINA'S"</p>	
<p>BOARD ACTION 1/7/85: MOTION, Jones/O'Brien and unanimously carried to continue to Feb. 4, 1985 when hopefully the applicant can be here to answer questions as to why the signs are necessary.</p>	
<p>2/4/85 O'Brien/Canclini to approve said signs being basically directory type will not detract from the building or other buildings in the district. Carried 5-0</p>	
<p>Approved by: <i>Thomas F. Arends</i> chairman</p>	

TO ● Dolores Spath	FROM MENDOCINO HISTORICAL REVIEW BOARD
● P. O. Box 57	P. O. Box 744
● Mendocino, Ca 95460 937-1234	Mendocino, California 95460 /
	APPL.# 85-02
	Date: 1 / 7 / 85
AP# 119-233-04 Street No. 45062 Ukiah (Beacon bldg)	
REQUEST: SIGN: 6" x 30" redwood "PANACHE"	
BOARD ACTION 1/7/85: MOTION, Jones/O'Brien and unanimously carried to continue to Feb. 4, 1985 when hopefully the applicant can be here to answer questions as to why the siggs are necessary.	
2/4/85 O'Brien/Canclini, to approve, said signs being basically directory type will not detract from the building or other buildings in the district. Carried 5-0.	
Approved by: <i>Eleanor J. Sverko</i> chairman	

Duplicates

**proposed
foyer addition
for
gallery mendocino
beacon building
mendocino, california**

#81-46

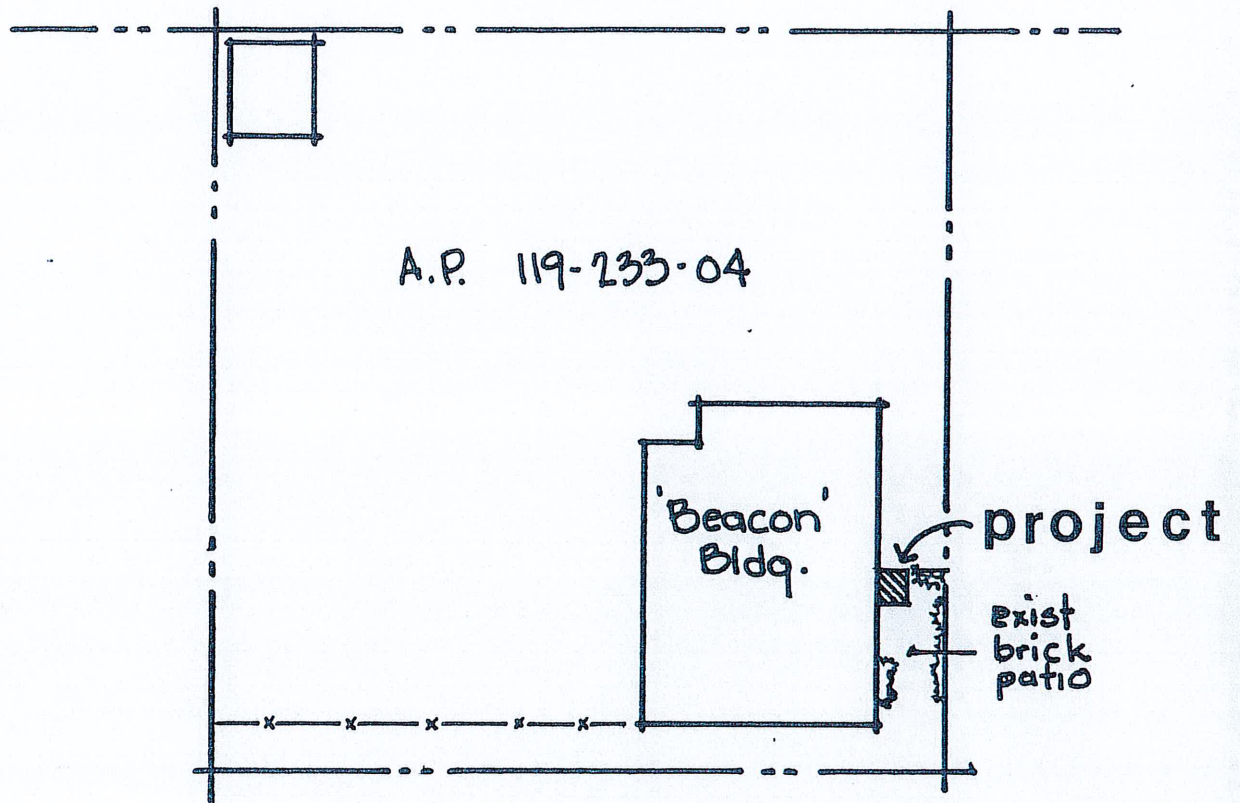

U k i a h S t.



plot plan

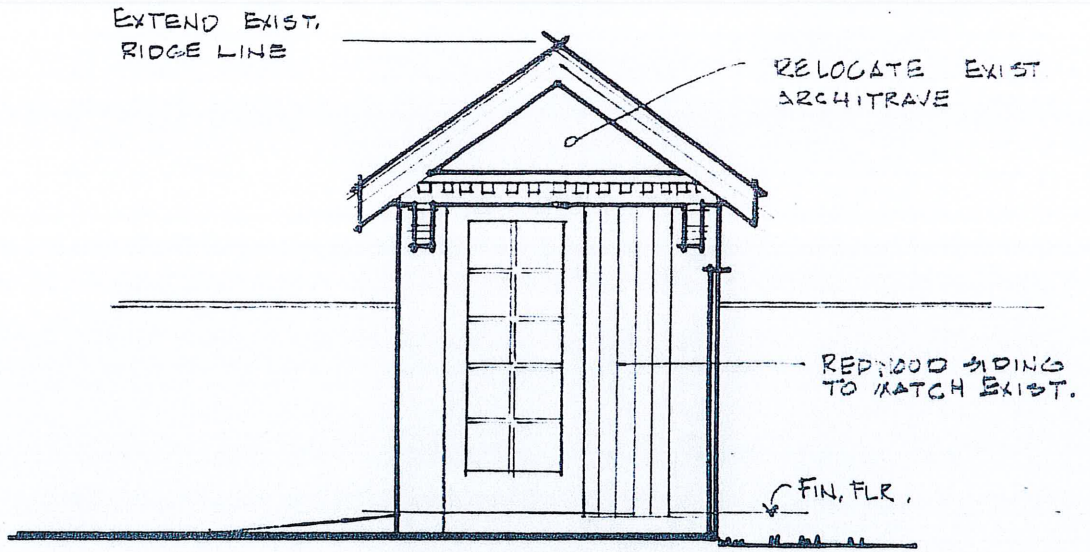

east elev.

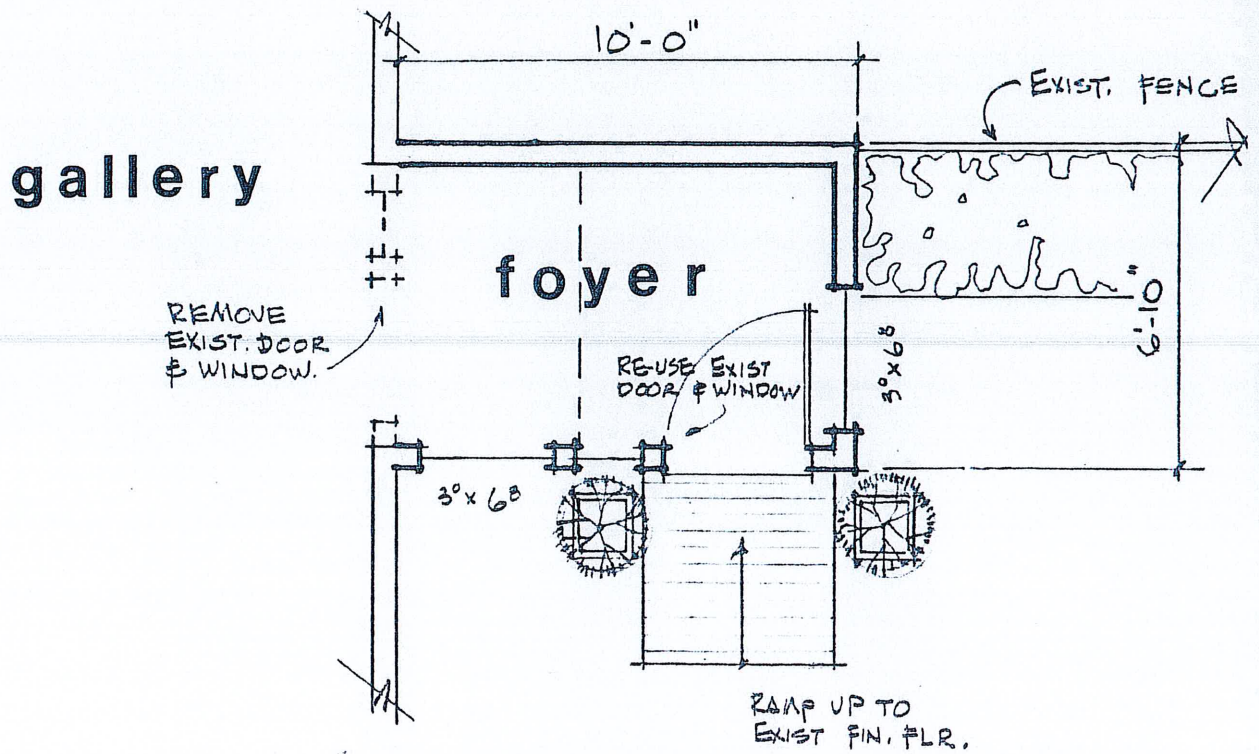

floor plan

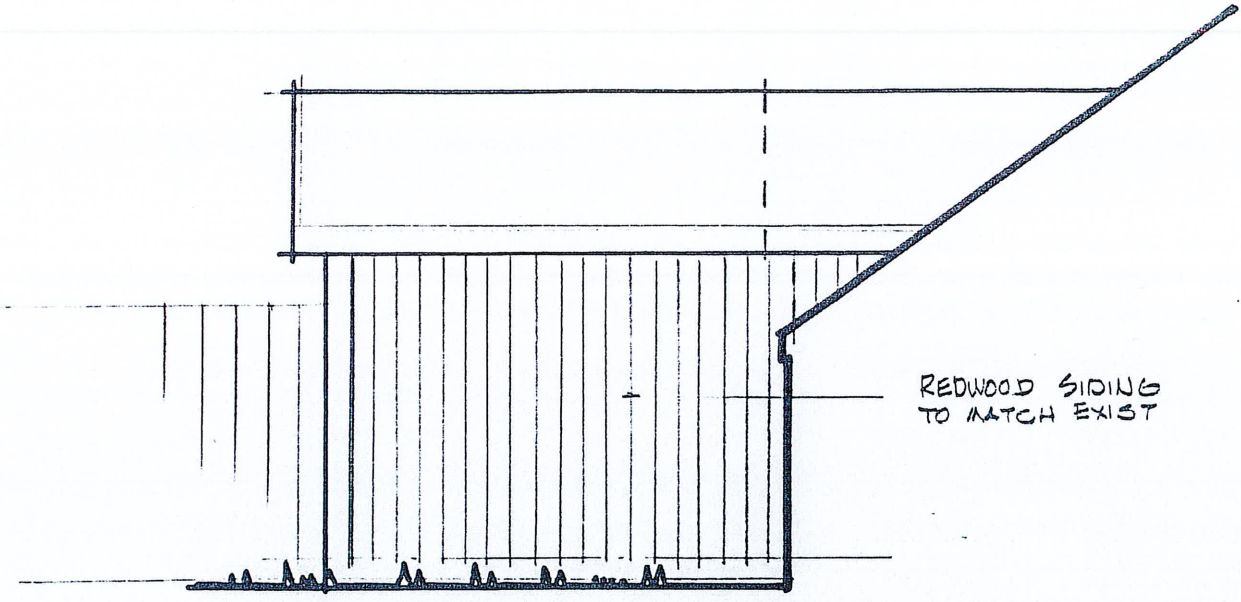

north elev.

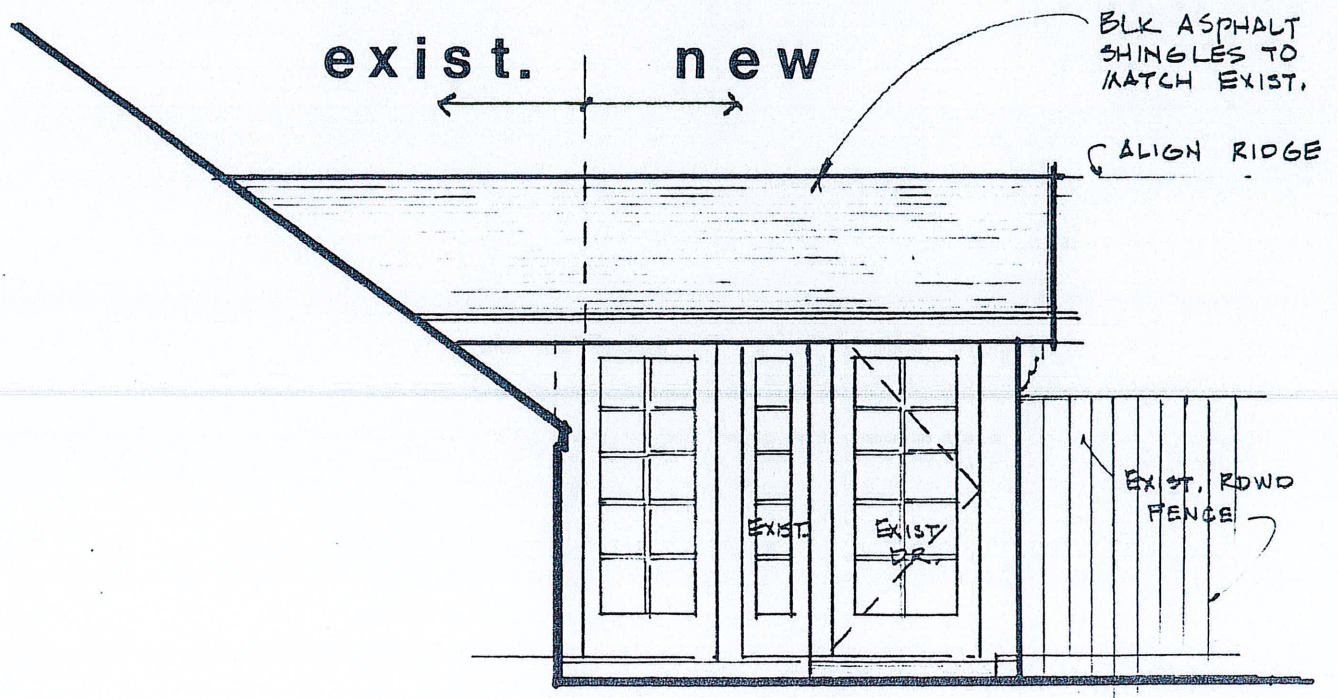

south elev.

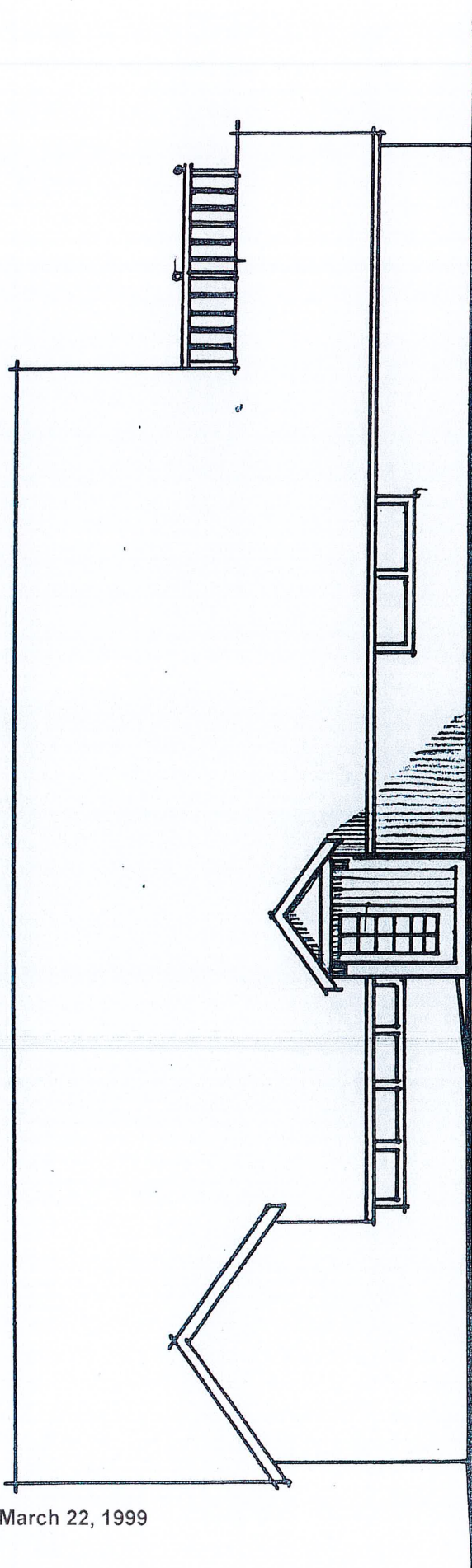

east elevation.

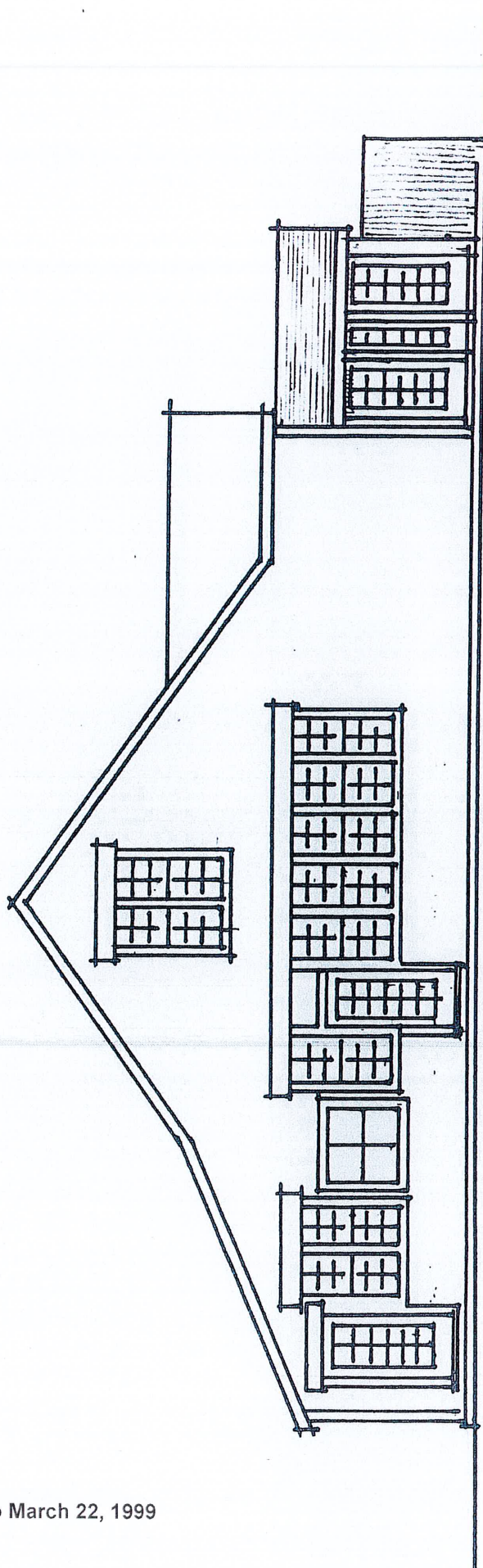

ukiah st. elevation

THE MENDOCINO COAST BEACON, Wednesday, July 21, 1976

PUBLIC NOTICE

**FICTITIOUS BUSINESS
NAME STATEMENT
ENDORSED-FILED
JUN 28 1976
VIOLA N. RICHARDSON
COUNTY CLERK**

The following persons are doing business as:

UKIAH GENERAL HOSPITAL
1120 South Dora Street
Ukiah, California 95482

1. Ukiah Hospital Corporation
a California corporation

This business is conducted by a corporation.

s-Charles L. Kown
Charles L. Kown, Secretary.

This statement was filed with the County Clerk of Mendocino County on June 28, 1976.

FILE NO. 76-U-6

CERTIFICATION

I hereby certify that the foregoing is a correct copy of the original on file in my office.

Viola N. Richardson,
County Clerk
Expires 12/31/1981
7-21, 28, 8-4, 11, 1976

The average American hen lays 217 eggs a year versus 203 for the average British hen!

PUBLIC NOTICE

**ENDORSED-FILED
JUL 7 1976
VIOLA RICHARDSON
COUNTY CLERK
FICTITIOUS BUSINESS
NAME STATEMENT**

File No. 76-M-18
Filing Fee-\$10.00

The following persons are doing business as:

MENDOCINO ANTIQUES
at Mendocino Beacon Building,
Mendocino, Calif. 95460.

1. **BIAGE QUATTROCCHI**
Gordon Lane, Star Rt.
Mendocino, Calif. 95460.

2. **JUNE T. QUATTROCCHI**
Wife

This business is conducted by an individual/husband & wife.

s-Biage Quattrocchi
This statement was filed with the County Clerk of Mendocino County on date indicated by file stamp above.

CERTIFICATION

I hereby certify that the foregoing is a correct copy of the original on file in my office.

VIOLA RICHARDSON
County Clerk
7-14, 21, 28, 8-4, 1976

**WE DRILL
WELLS**

Kelly Pump & Drilling
18779 N. Hwy. 1
Box 272—Fort Bragg

**Call Now For FREE
Estimates- 964-9326**

**SUMMER
SPECIAL**



In the months of June & July,
sign up to drill a well & we'll
give you 1/2 off any pump & tank.
Look into our Goulds submersibles
and well-x-trol tanks.

Both guaranteed for 5 years.
Between Kelly Pump & Drilling &
Goulds water systems, we can
solve your water needs.

**THE
GALLERY
BOOKSHOP
•
1971
CALENDARS**

"Wild Fowl Portfolio"
By Rosemary Allen

Anglund Date Book
By Joan Walsh

Peanuts • UNICEF
Sierra Club - and More

•
Books - Art Supplies
Stationery - Gallery
Greeting Cards

319 Kasten Street
Mendocino

11-6-1976

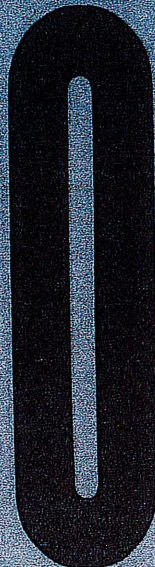

☆
ART DIRECTORS

☆
**ADVERTISING
AGENCIES**



Available for your use:

Fabulous wood type of
The Mendocino Beacon.

For details call
our Curator*, William
Graubard, (707) 937-5874,
or write:

THE MENDOCINO BEACON
Mendocino, Calif. 95460

(*also known as advertising manager)