

MEETING AGENDA
Mental Health Treatment Act
Citizens Oversight Committee

Mendocino County Offsite and Online due to COVID-19
Phone: (707) 510-6637 and Email: measureb@mendocinocounty.org

Teleconferencing to be hosted from 1120 S. Dora St. in Ukiah, California
Zoom Video Conferencing - <https://mendocinocounty.zoom.us/j/92834815478>
ID: 928 3481 5478, Call-In: 1(669) 900-9128 or 1 (253) 215-8782
Wednesday, August 26, 2020 - 1:00 P.M.

1. OPEN SESSION/ROLL CALL

2. PUBLIC EXPRESSION ON NON-AGENDA ITEMS

Members of the public are welcome to address the Committee on items not listed on the agenda but within the jurisdiction of the Committee. The Committee is prohibited by law from taking action on matters, not on the agenda but may ask questions to clarify the speaker's comment. The Committee limits testimony on matters not on the agenda to three minutes per person and not more than 10 minutes for a particular subject at the discretion of the Chair of the Committee.

To best facilitate these items, please write your topic to measureb@mendocinocounty.org
All meetings are recorded.
Once your item is announced, please state your first and last name.

3. COMMITTEE MATTERS

3a) Approval of Minutes from the July 22, 2020 Meeting.

3b) Discussion and Possible Action to Accept Action Minutes for Committee Meetings in Place of Summary Minutes.

3c) Discussion and Possible Action regarding the Auditor's Expenditure Report and Measure B Programs Budget.

3d) Discussion and Possible Action Regarding the Crisis Residential Facility as Voted

All other participants will be calling in from Fort Bragg, CA; Willits, CA; and Ukiah, CA
Due to COVID-19 Social Distancing requirements, the public is invited to participate ONLINE ONLY

For information regarding the Brown Act for offsite/online public meetings, visit:
<https://www.gov.ca.gov/wp-content/uploads/2020/03/3.12.20-EO-N-25-20-COVID-19.pdf>

MEETING AGENDA

Mental Health Treatment Act

Citizens Oversight Committee

Mendocino County Offsite and Online due to COVID-19
Phone: (707) 510-6637 and Email: measureb@mendocinocounty.org

Upon by the Board of Supervisors on Aug. 18, 2020, and the Associated CHFFA Grant.

- 3e) Discussion of Kemper Ad Hoc Committee Suggestions and AD Hoc Report.
 - 3f) Discussion and Possible Action Regarding BHRTC Ad Hoc Approval of Fixed Asset Over \$5000 Purchase: Gun Locker for BHRTC.
 - 3g) Measure B Project Management Report.
4. COMMITTEE MEMBER REPORTS
- 4a) Committee Member Reports regarding Items of General Interest
5. COMMUNICATIONS RECEIVED AND FILED
Communications received and filed are retained by the Clerk throughout the Committee proceedings. To review items described in this section, please contact the Committee Clerk at measureb@mendocinocounty.org

ADJOURNMENT

The Committee complies with ADA requirements and upon request, will attempt to reasonably accommodate individuals with disabilities by making meeting materials available in appropriate formats (pursuant to Government Code section 54953.2)

Anyone requiring reasonable accommodation to participate in the meeting should contact the Committee clerk by calling (707) 510-6637 at least five days prior to the Meeting. Additional information regarding the Committee can be obtained by referencing:

www.mendocinocounty.org/community/mental-healthoversight-committee

All other participants will be calling in from Fort Bragg, CA; Willits, CA; and Ukiah, CA
Due to COVID-19 Social Distancing requirements, the public is invited to participate ONLINE ONLY

For information regarding the Brown Act for offsite/online public meetings, visit:
<https://www.gov.ca.gov/wp-content/uploads/2020/03/3.12.20-EO-N-25-20-COVID-19.pdf>

ITEM 3a

Date of Meeting:	August 26, 2020
Contact:	Chair D. Moschetti
	Time Allocated for Item: 5 minutes

AGENDA TITLE: Approval of Minutes from the July 22, 2020 Meeting.

SUMMARY OF REQUEST / BACKGROUND INFORMATION:

See Attached

ITEM 3b

Date of Meeting:	August 26, 2020
Contact:	Ms. S. Riley
	Time Allocated for Item: 5 minutes

AGENDA TITLE: Discussion and Possible Action to Accept Action Minutes for Committee Meetings in Place of Summary Minutes.

SUMMARY OF REQUEST / BACKGROUND INFORMATION:

Current/Summary Minutes are time-consuming for both the Measure B Staff to dictate, and the Committee to read and edit.

ITEM 3c

Date of Meeting:	August 26, 2020
Contact:	Mr. L. Weer (Auditor) and Alyson Bailey P.M.
	Time Allocated for Item: 15 minutes

AGENDA TITLE: Discussion and Possible Action regarding the Auditor's Expenditure Report and Measure B Programs Budget.

SUMMARY OF REQUEST / BACKGROUND INFORMATION:

Program Budget and Monthly Fiscal Line-Item Report Attached

FOR 2021 12

JOURNAL DETAIL 2021 1 TO 2021 12

	ORIGINAL APPROP	TRANFRS/ ADJSTMTS	REVISED BUDGET	YTD ACTUAL	ENCUMBRANCES	AVAILABLE BUDGET	PCT USED

4052 MENTAL HEALTH TREATMENT							

821500 SALES & USE TAX	-8,500,000	0	-8,500,000	.00	.00	-8,500,000.00	.0%
824100 INTEREST	-200,000	0	-200,000	.00	.00	-200,000.00	.0%
861011 REGULAR EMPLOYEES	84,250	0	84,250	9,472.18	.00	74,777.82	11.2%
861021 CO CONT TO RETIREMENT	27,330	0	27,330	3,072.78	.00	24,257.22	11.2%
861022 CO CONT TO OASDI	5,220	0	5,220	585.93	.00	4,634.07	11.2%
861023 CO CONT TO OASDI-MEDIC	1,220	0	1,220	137.03	.00	1,082.97	11.2%
861024 CO CONT TO RET INCREMENT	4,490	0	4,490	504.87	.00	3,985.13	11.2%
861030 CO CONT TO EMPLOYEE INSURANC	6,290	0	6,290	2,087.21	.00	4,202.79	33.2%
862060 COMMUNICATIONS	350	0	350	55.20	.00	294.80	15.8%
862101 INSURANCE-GENERAL	425	0	425	.00	.00	425.00	.0%
862170 OFFICE EXPENSE	2,000	0	2,000	948.00	.00	1,052.00	47.4%
862187 EDUCATION & TRAINING	1,000	0	1,000	.00	.00	1,000.00	.0%
862189 PROF & SPEC SVCS-OTHR	50,000	0	50,000	.00	.00	50,000.00	.0%
862190 PUBL & LEGAL NOTICES	500	0	500	.00	.00	500.00	.0%
862230 INFO TECH EQUIP	1,500	0	1,500	.00	.00	1,500.00	.0%
862239 SPEC DEPT EXP	100,000	0	100,000	.00	.00	100,000.00	.0%
862250 TRNSPRTATION & TRAVEL	500	0	500	.00	.00	500.00	.0%
862253 TRAVEL & TRSP OUT OF COUNTY	1,500	0	1,500	.00	.00	1,500.00	.0%
865802 OPERATING TRANSFER OUT	2,706,600	0	2,706,600	.00	.00	2,706,600.00	.0%
TOTAL MENTAL HEALTH TREATMENT	-5,706,825	0	-5,706,825	16,863.20	.00	-5,723,688.20	-.3%
TOTAL REVENUES	-8,700,000	0	-8,700,000	.00	.00	-8,700,000.00	
TOTAL EXPENSES	2,993,175	0	2,993,175	16,863.20	.00	2,976,311.80	
GRAND TOTAL	-5,706,825	0	-5,706,825	16,863.20	.00	-5,723,688.20	-.3%

** END OF REPORT - Generated by Lloyd Weer **

FOR 2021 12

JOURNAL DETAIL 2021 1 TO 2021 12

	ORIGINAL APPROP	TRANFRS/ ADJSTMTS	REVISED BUDGET	YTD ACTUAL	ENCUMBRANCES	AVAILABLE BUDGET	PCT USED

ME 861011 REGULAR EMPLOYEES							
2021/02/000406 08/14/2020 PRJ	3,382.92	REF PP1720			WARRANT=PP1720	RUN=1 BIWEEKLY	
TOTAL REGULAR EMPLOYEES	84,250	0	84,250	9,472.18	.00	74,777.82	11.2%
861012 EXTRA HELP							

ME 861012 EXTRA HELP	0	0	0	.00	.00	.00	.0%
TOTAL EXTRA HELP	0	0	0	.00	.00	.00	.0%
861013 OVERTIME REG EMP							

ME 861013 OVERTIME REG EMP	0	0	0	.00	.00	.00	.0%
TOTAL OVERTIME REG EMP	0	0	0	.00	.00	.00	.0%
861021 CO CONT TO RETIREMENT							

ME 861021 CO CONT TO RETIREMENT	27,330	0	27,330	3,072.78	.00	24,257.22	11.2%
2021/01/000325 07/17/2020 PRJ	877.94	REF PP1520			WARRANT=PP1520	RUN=1 BIWEEKLY	
2021/01/000690 07/31/2020 PRJ	1,097.42	REF PP1620			WARRANT=PP1620	RUN=1 BIWEEKLY	
2021/02/000406 08/14/2020 PRJ	1,097.42	REF PP1720			WARRANT=PP1720	RUN=1 BIWEEKLY	
TOTAL CO CONT TO RETIREMENT	27,330	0	27,330	3,072.78	.00	24,257.22	11.2%
861022 CO CONT TO OASDI							

ME 861022 CO CONT TO OASDI	5,220	0	5,220	585.93	.00	4,634.07	11.2%
2021/01/000325 07/17/2020 PRJ	167.41	REF PP1520			WARRANT=PP1520	RUN=1 BIWEEKLY	
2021/01/000690 07/31/2020 PRJ	209.26	REF PP1620			WARRANT=PP1620	RUN=1 BIWEEKLY	
2021/02/000406 08/14/2020 PRJ	209.26	REF PP1720			WARRANT=PP1720	RUN=1 BIWEEKLY	

FOR 2021 12

JOURNAL DETAIL 2021 1 TO 2021 12

	ORIGINAL APPROP	TRANFRS/ ADJSTMTS	REVISED BUDGET	YTD ACTUAL	ENCUMBRANCES	AVAILABLE BUDGET	PCT USED
TOTAL CO CONT TO OASDI	5,220	0	5,220	585.93	.00	4,634.07	11.2%

861023 CO CONT TO OASDI-MEDIC							
ME 861023 CO CONT TO OASDI-MEDI	1,220	0	1,220	137.03	.00	1,082.97	11.2%
2021/01/000325 07/17/2020 PRJ	39.15	REF PP1520			WARRANT=PP1520	RUN=1 BIWEEKLY	
2021/01/000690 07/31/2020 PRJ	48.94	REF PP1620			WARRANT=PP1620	RUN=1 BIWEEKLY	
2021/02/000406 08/14/2020 PRJ	48.94	REF PP1720			WARRANT=PP1720	RUN=1 BIWEEKLY	
TOTAL CO CONT TO OASDI-MEDIC	1,220	0	1,220	137.03	.00	1,082.97	11.2%

861024 CO CONT TO RET INCREMENT							
ME 861024 CO CONT TO RET INCREM	4,490	0	4,490	504.87	.00	3,985.13	11.2%
2021/01/000325 07/17/2020 PRJ	144.25	REF PP1520			WARRANT=PP1520	RUN=1 BIWEEKLY	
2021/01/000690 07/31/2020 PRJ	180.31	REF PP1620			WARRANT=PP1620	RUN=1 BIWEEKLY	
2021/02/000406 08/14/2020 PRJ	180.31	REF PP1720			WARRANT=PP1720	RUN=1 BIWEEKLY	
TOTAL CO CONT TO RET INCREMENT	4,490	0	4,490	504.87	.00	3,985.13	11.2%

861030 CO CONT TO EMPLOYEE INSURANCE							
ME 861030 CO CONT TO EMPLOYEE I	6,290	0	6,290	2,087.21	.00	4,202.79	33.2%
2021/01/000325 07/17/2020 PRJ	596.35	REF PP1520			WARRANT=PP1520	RUN=1 BIWEEKLY	
2021/01/000690 07/31/2020 PRJ	745.43	REF PP1620			WARRANT=PP1620	RUN=1 BIWEEKLY	
2021/02/000406 08/14/2020 PRJ	745.43	REF PP1720			WARRANT=PP1720	RUN=1 BIWEEKLY	
TOTAL CO CONT TO EMPLOYEE INSURANCE	6,290	0	6,290	2,087.21	.00	4,202.79	33.2%

861031 CO CONT UNEMPLOYMENT INSURANCE							
ME 861031 CO CONT UNEMPLOYMENT	0	0	0	.00	.00	.00	.0%

FOR 2021 12

JOURNAL DETAIL 2021 1 TO 2021 12

	ORIGINAL APPROP	TRANFRS/ ADJSTMTS	REVISED BUDGET	YTD ACTUAL	ENCUMBRANCES	AVAILABLE BUDGET	PCT USED
TOTAL CO CONT UNEMPLOYMENT INSURANCE	0	0	0	.00	.00	.00	.0%
861035 CO CONT WORKERS COMPENSATION I							
ME 861035 CO CONT WORKERS COMPE	0	0	0	.00	.00	.00	.0%
TOTAL CO CONT WORKERS COMPENSATION I	0	0	0	.00	.00	.00	.0%
862060 COMMUNICATIONS							
ME 862060 COMMUNICATIONS	350	0	350	55.20	.00	294.80	15.8%
2021/02/000516 08/20/2020 API	55.20	VND 005294 IN 9858158289		VERIZON WIRELESS	270569046-00035		
TOTAL COMMUNICATIONS	350	0	350	55.20	.00	294.80	15.8%
862080 FOOD							
ME 862080 FOOD	0	0	0	.00	.00	.00	.0%
TOTAL FOOD	0	0	0	.00	.00	.00	.0%
862090 HOUSEHOLD EXPENSE							
ME 862090 HOUSEHOLD EXPENSE	0	0	0	.00	.00	.00	.0%
TOTAL HOUSEHOLD EXPENSE	0	0	0	.00	.00	.00	.0%
862101 INSURANCE-GENERAL							
ME 862101 INSURANCE-GENERAL	425	0	425	.00	.00	425.00	.0%
TOTAL INSURANCE-GENERAL	425	0	425	.00	.00	425.00	.0%

FOR 2021 12

JOURNAL DETAIL 2021 1 TO 2021 12

	ORIGINAL APPROP	TRANFRS/ ADJSTMTS	REVISED BUDGET	YTD ACTUAL	ENCUMBRANCES	AVAILABLE BUDGET	PCT USED

862120 MAINTENANCE-EQUIPMENT							

ME 862120 MAINTENANCE-EQUIPMENT	0	0	0	.00	.00	.00	.0%
TOTAL MAINTENANCE-EQUIPMENT	0	0	0	.00	.00	.00	.0%
862130 MAINT-STRC IMPR & GRN							

ME 862130 MAINT-STRC IMPR & GRN	0	0	0	.00	.00	.00	.0%
TOTAL MAINT-STRC IMPR & GRN	0	0	0	.00	.00	.00	.0%
862150 MEMBERSHIPS							

ME 862150 MEMBERSHIPS	0	0	0	.00	.00	.00	.0%
TOTAL MEMBERSHIPS	0	0	0	.00	.00	.00	.0%
862170 OFFICE EXPENSE							

ME 862170 OFFICE EXPENSE	2,000	0	2,000	948.00	.00	1,052.00	47.4%
2021/02/000456 08/18/2020 GNI			948.00 REF				
TOTAL OFFICE EXPENSE	2,000	0	2,000	948.00	.00	1,052.00	47.4%
862182 DATA PROCESSING SERVICES							

ME 862182 DATA PROCESSING SERVI	0	0	0	.00	.00	.00	.0%
TOTAL DATA PROCESSING SERVICES	0	0	0	.00	.00	.00	.0%
862185 MEDICAL & DENTAL SVCS							

ME 862185 MEDICAL & DENTAL SVCS	0	0	0	.00	.00	.00	.0%

BLN monday.c63090.0007/29/202

FOR 2021 12

JOURNAL DETAIL 2021 1 TO 2021 12

	ORIGINAL APPROP	TRANFRS/ ADJSTMTS	REVISED BUDGET	YTD ACTUAL	ENCUMBRANCES	AVAILABLE BUDGET	PCT USED
TOTAL MEDICAL & DENTAL SVCS	0	0	0	.00	.00	.00	.0%
862187 EDUCATION & TRAINING							
ME 862187 EDUCATION & TRAINING	1,000	0	1,000	.00	.00	1,000.00	.0%
TOTAL EDUCATION & TRAINING	1,000	0	1,000	.00	.00	1,000.00	.0%
862189 PROF & SPEC SVCS-OTHR							
ME 862189 PROF & SPEC SVCS-OTHR	50,000	0	50,000	.00	.00	50,000.00	.0%
TOTAL PROF & SPEC SVCS-OTHR	50,000	0	50,000	.00	.00	50,000.00	.0%
862190 PUBL & LEGAL NOTICES							
ME 862190 PUBL & LEGAL NOTICES	500	0	500	.00	.00	500.00	.0%
TOTAL PUBL & LEGAL NOTICES	500	0	500	.00	.00	500.00	.0%
862194 A-87 COSTS							
ME 862194 A-87 COSTS	0	0	0	.00	.00	.00	.0%
TOTAL A-87 COSTS	0	0	0	.00	.00	.00	.0%
862200 RNTS & LEASES-EQPMNT							
ME 862200 RNTS & LEASES-EQPMNT	0	0	0	.00	.00	.00	.0%

FOR 2021 12

JOURNAL DETAIL 2021 1 TO 2021 12

	ORIGINAL APPROP	TRANFRS/ ADJSTMTS	REVISED BUDGET	YTD ACTUAL	ENCUMBRANCES	AVAILABLE BUDGET	PCT USED
TOTAL RNTS & LEASES-EQPMNT	0	0	0	.00	.00	.00	.0%

862210 RNTS & LEASES BLD GRD							
ME 862210 RNTS & LEASES BLD GRD	0	0	0	.00	.00	.00	.0%
TOTAL RNTS & LEASES BLD GRD	0	0	0	.00	.00	.00	.0%

862230 INFO TECH EQUIP							
ME 862230 INFO TECH EQUIP	1,500	0	1,500	.00	.00	1,500.00	.0%
2021/01/000324 07/08/2020 GNI	68.74	REF				CDW GOVT #4063095.6006/15/202	
2021/01/000324 07/08/2020 GNI	264.77	REF				CDW GOVT #4063090.0006/15/202	
2021/01/000324 07/08/2020 GNI	880.17	REF				GRANITE DAT630971.3506/17/202	
2021/01/000341 07/08/2020 GRV	-68.74	REF				JUNE 20 PCARD	
2021/01/000341 07/08/2020 GRV	-264.77	REF				JUNE 20 PCARD	
2021/01/000341 07/08/2020 GRV	-880.17	REF				JUNE 20 PCARD	
TOTAL INFO TECH EQUIP	1,500	0	1,500	.00	.00	1,500.00	.0%

862239 SPEC DEPT EXP							
ME 862239 SPEC DEPT EXP	100,000	0	100,000	.00	.00	100,000.00	.0%
TOTAL SPEC DEPT EXP	100,000	0	100,000	.00	.00	100,000.00	.0%

862250 TRNSPRTATION & TRAVEL							
ME 862250 TRNSPRTATION & TRAVEL	500	0	500	.00	.00	500.00	.0%
TOTAL TRNSPRTATION & TRAVEL	500	0	500	.00	.00	500.00	.0%

862253 TRAVEL & TRSP OUT OF COUNTY							

FOR 2021 12

JOURNAL DETAIL 2021 1 TO 2021 12

	ORIGINAL APPROP	TRANFRS/ ADJSTMTS	REVISED BUDGET	YTD ACTUAL	ENCUMBRANCES	AVAILABLE BUDGET	PCT USED
ME 862253 TRAVEL & TRSP OUT OF	1,500	0	1,500	.00	.00	1,500.00	.0%
TOTAL TRAVEL & TRSP OUT OF COUNTY	1,500	0	1,500	.00	.00	1,500.00	.0%
862260 UTILITIES							
ME 862260 UTILITIES	0	0	0	.00	.00	.00	.0%
TOTAL UTILITIES	0	0	0	.00	.00	.00	.0%
863124 GR-SSI-SSP APPLCNTS							
ME 863124 GR-SSI-SSP APPLCNTS	0	0	0	.00	.00	.00	.0%
TOTAL GR-SSI-SSP APPLCNTS	0	0	0	.00	.00	.00	.0%
863280 CONTR TO OTHER AGNCS							
ME 863280 CONTR TO OTHER AGNCS	0	0	0	.00	.00	.00	.0%
TOTAL CONTR TO OTHER AGNCS	0	0	0	.00	.00	.00	.0%
864370 EQUIPMENT							
ME 864370 EQUIPMENT	0	0	0	.00	.00	.00	.0%
TOTAL EQUIPMENT	0	0	0	.00	.00	.00	.0%
865380 INTRAFUND TRANSFERS							
ME 865380 INTRAFUND TRANSFERS	0	0	0	.00	.00	.00	.0%

FOR 2021 12

JOURNAL DETAIL 2021 1 TO 2021 12

	ORIGINAL APPROP	TRANFRS/ ADJSTMTS	REVISED BUDGET	YTD ACTUAL	ENCUMBRANCES	AVAILABLE BUDGET	PCT USED
TOTAL INTRAFUND TRANSFERS	0	0	0	.00	.00	.00	.0%

865802 OPERATING TRANSFER OUT							
ME 865802 OPERATING TRANSFER OU	2,706,600	0	2,706,600	.00	.00	2,706,600.00	.0%
TOTAL OPERATING TRANSFER OUT	2,706,600	0	2,706,600	.00	.00	2,706,600.00	.0%
TOTAL MENTAL HEALTH TREATMENT	-5,706,825	0	-5,706,825	16,863.20	.00	-5,723,688.20	-.3%
TOTAL REVENUES	-8,700,000	0	-8,700,000	.00	.00	-8,700,000.00	
TOTAL EXPENSES	2,993,175	0	2,993,175	16,863.20	.00	2,976,311.80	
GRAND TOTAL	-5,706,825	0	-5,706,825	16,863.20	.00	-5,723,688.20	-.3%

** END OF REPORT - Generated by Lloyd Weer **

**Mendocino County - Measure B Funds
Mental Health Treatment Act**

Revenue and Expenses - Life to Date			Fund 1224, Budget Unit 4052		
Date	Invoice, CRP, Journal No.	Description	Amount	Min 25% Operations	Max 75% Facilities
Revenues:					
2017/18	Total	Measure B Sales Tax Proceeds - April 2018 to June 2018	(1,606,571)	(401,643)	(1,204,929)
2018/19	Total	Measure B Sales Tax Proceeds - July 2018 to June 2019	(8,555,373)	(2,138,843)	(6,416,529)
9/25/2019	CRP 205798	Measure B Sales Tax Proceeds - July 2019	(739,098)	(184,775)	(554,324)
10/25/2019	CRP 207136	Measure B Sales Tax Proceeds - August 2019	(910,284)	(227,571)	(682,713)
11/26/2019	CRP 208392	Measure B Sales Tax Proceeds - September 2019	(652,027)	(163,007)	(489,020)
12/26/2019	CRP 209528	Measure B Sales Tax Proceeds - October 2019	(682,105)	(170,526)	(511,579)
1/27/2020	CRP 210703	Measure B Sales Tax Proceeds - November 2019	(776,491)	(194,123)	(582,368)
2/26/2020	CRP 212294	Measure B Sales Tax Proceeds - December 2019	(909,310)	(227,328)	(681,983)
3/26/2020	CRP 213469	Measure B Sales Tax Proceeds - January 2020	(586,257)	(146,564)	(439,693)
4/27/2020	CRP 214391	Measure B Sales Tax Proceeds - February 2020	(620,557)	(155,139)	(465,418)
5/27/2020	CRP 215310	Measure B Sales Tax Proceeds - March 2020	(476,511)	(119,128)	(357,383)
6/25/2020	CRP 216478	Measure B Sales Tax Proceeds - April 2020	(566,667)	(141,667)	(425,000)
6/30/2020	CRP 217735	Measure B Sales Tax Proceeds - May 2020	(895,873)	(223,968)	(671,905)
		Life to Date Revenue:	(17,977,124)	(4,494,281)	(13,482,843)
Expenses:					
2017/18	Total	Measure B Expenditures - April 2018 to June 2018	199,048	199,048	0
2018/19	Total	Measure B Expenditures - July 2018 to June 2019	31,389	31,389	0
8/22/2019	INV 080119	Sarah A. Riley - Consulting Services Measure B	1,740	1,740	0
9/19/2019	INV 090119	Sarah A. Riley - Consulting Services Measure B	540	540	0
9/23/2019	GEN JE 811	First American Title - Purchase Training Facility (70%)	274,457	0	274,457
10/18/2019	INV 100119	Sarah A. Riley - Consulting Services Measure B	2,700	2,700	0
10/25/2019	GEN JE 987	CEO Labor and Benefits - X. UNG hours worked	2,986	2,986	0
10/25/2019	GEN JE 987	Nash Gonzalez - Consulting time Measure B	7,063	7,063	0
11/15/2019	INV 110119	Sarah A. Riley - Consulting Services Measure B	1,800	1,800	0
12/19/2019	INV 120119	Sarah A. Riley - Consulting Services Measure B	1,320	1,320	0
1/16/2020	INV 010220	Sarah A. Riley - Consulting Services Measure B	480	480	0
1/30/2020	INV 984576	Verizon Wireless - cell phone	50	50	0
2/13/2020	INV 020320	Sarah A. Riley - Consulting Services Measure B	1,320	1,320	0
2/27/2020	INV 984783	Verizon Wireless - cell phone	25	25	0
3/11/2020	GEN JE 445	CEO Labor and Benefits - X. UNG hours worked	2,221	2,221	0
3/11/2020	GEN JE 038	Nash Gonzalez - Consulting time Measure B	1,875	1,875	0
3/26/2020	INV 1242290	Fishman Supply co. - office supplies	8	8	0
4/2/2020	INV 910009510	AT&T Teleconference	126	126	0
4/2/2020	INV 030220	Sarah A. Riley - Consulting Services Measure B	864	864	0
4/30/2020	INV 98522011427	Verizon Wireless - cell phone	46	46	0
4/30/2020	INV 040120	Sarah A. Riley - Consulting Services Measure B	840	840	0
5/28/2020	INV 9854069945	Verizon Wireless - cell phone	77	77	0
6/9/2020	GEN JE 284	Laptop for Measure B	1,052	1,052	0
6/25/2020	INV 9854069945	Verizon Wireless - cell phone	66	66	0
6/30/2020	GEN JE 1322	Measure B Salary and Benefits - A. Blair PP14	5,384	5,384	0
6/30/2020	GEN JE 1808	Measure B Salary and Benefits - A. Blair PP15	1,133	1,133	0
6/30/2020	GEN JE 2525	Sonoma Media	600	600	0
6/30/2020	GEN JE 1855	CDW GOVT and Granite Data - Pcard	1,214	1,214	0
6/30/2020	GEN JE 1603	GMR Transcription July - March 2020	1,679	1,679	0
6/30/2020	Reimbursement	Regional Training Center Remodel costs to date	33,557		33,557
6/30/2020	Reimbursement	Crisis Residential Treatment Facility Design costs	224,468		224,468
		Life to Date Expense:	800,128	267,646	532,482
		Life to Date Interest Earnings:	(302,471)	(75,618)	(226,853)
		Current Measure B Fund Balance:	(17,479,467)	(4,302,252)	(13,177,214)
		Measure B Prudent Reserve at 6.35%:	(1,109,946)	(277,487)	(832,460)

ITEM 3d

Date of Meeting:	August 26, 2020
Contact:	Dr. J. Miller and Alyson Bailey P.M.
	Time Allocated for Item: 15 minutes

AGENDA TITLE: Discussion and Possible Action Regarding the Crisis Residential Facility as Voted Upon by the Board of Supervisors on Aug. 18, 2020, and the Associated CHFFA Grant.

SUMMARY OF REQUEST / BACKGROUND INFORMATION:

The Board of Supervisors unanimously granted Measure B the means to complete the CRT project on Orchard Avenue in Ukiah.

The vote approved all soft costs, including Construction Management with AECOM, all Contractor fees and RFP processes, Construction of the facility, including parking, landscape, fencing, and all items needed to make the beautiful design by Nacht & Lewis a reality.

The RFQ for the CRT is now being advertising on our County website, and will soon help us determine the operational portion of this project.

ITEM 3e

Date of Meeting:	August 26, 2020
Contact:	Ms. C. Angelo, Dr. J. Miller, Chair D. Moschetti
	Time Allocated for Item: 15 minutes

AGENDA TITLE: Discussion of Kemper Ad Hoc Committee Suggestions and AD Hoc Report.

SUMMARY OF REQUEST / BACKGROUND INFORMATION:

Update on recommended Kemper items: Community Education Services, Mobile Outreach, Supportive Housing, and Aftercare Services.

Details:

A one-time allocation of One Million - Three Hundred Thousand dollars (\$1,300,000) to purchase and renovate or build permanent housing for individuals on the coast [in a location to be decided] who are homeless, chronically homeless, or at risk of chronic homelessness who have a mental health condition. In addition, the committee requests that this effort includes the pursuit of matching funds.

Contract with a behavioral health-related agency for community education and support services in the amount of \$350,000 per year for four (4) years (\$1,400,000 total) be developed, authorizing the Behavioral Health Director to award and sign-off on the agreement.

Two-hundred sixty thousand dollars (\$260,000) per year for four (4) years (\$1,040,000 total) to provide follow-up services to all individuals not eligible for County [Medical] services who are being discharged from a psychiatric hospital stay; receiving a 51/50 assessment.

Mobile Crisis Team in partnership with local law enforcement to be reviewed in six months. Original ask: \$340,000 a year for four (4) years (\$1,360,000 total).

All Four Services Total: 5.1 million
Projected Operations Fund: 9.743 million
Projected Remainder: 4.643 million

ITEM 3f

Date of Meeting:	August 26, 2020
Contact:	Alyson Bailey P.M.
	Time Allocated for Item: 10 minutes

AGENDA TITLE:

SUMMARY OF REQUEST / BACKGROUND INFORMATION: Discussion and Possible Action Regarding BHRTC Ad Hoc Approval of Fixed Asset Over \$5000 Purchase: Gun Locker for BHRTC.

The Behavioral Health Regional Training Center is close to completion. Plans for sitework and remodeling have been submitted, and the bid process to hire a contractor is underway.

Identifying, purchasing, and installing the equipment needed in order to create a successful business will take place from now through the end of the year.

The gun locker is one of those necessary pieces of equipment, and the ad hoc committee for this projected voted to purchase the gun locker during their June 2020 meeting.

There is concern that seeing a gun locker upon walking into a Behavioral Health space will create an off-brand, uncomfortable ambiance. This is why the gun locker will be installed in the storage area where the device and its contents will be safely placed behind locked doors, out of sight.

Let it be understood that this venue is a place of equality, safety, vulnerability, and learning for all Behavioral Health stakeholders: Clients, Social Workers, Administrators, Doctors, First Responders, Families, and others.

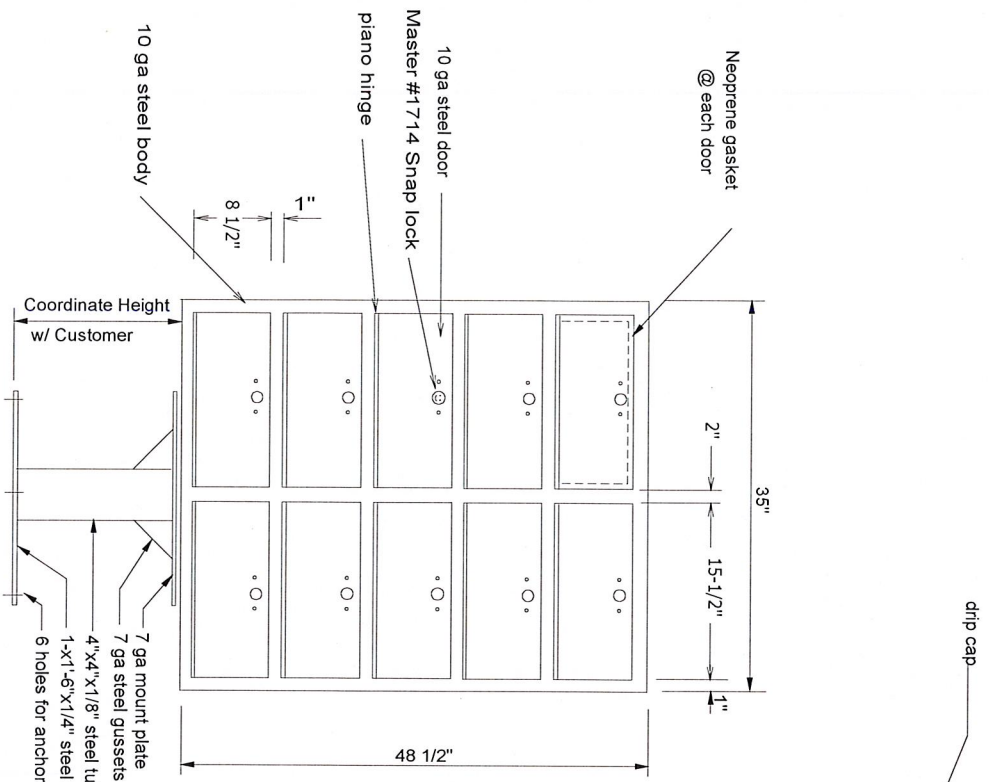

ELEVATION

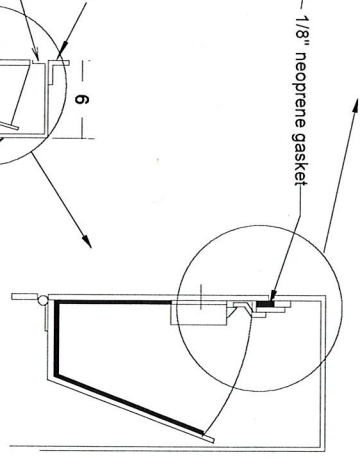
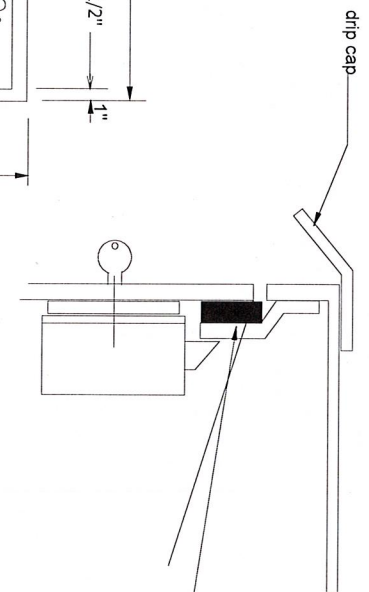

FL-708-10-WP , 10 Compartment Pistol Locker

Zinc plated Powder coat

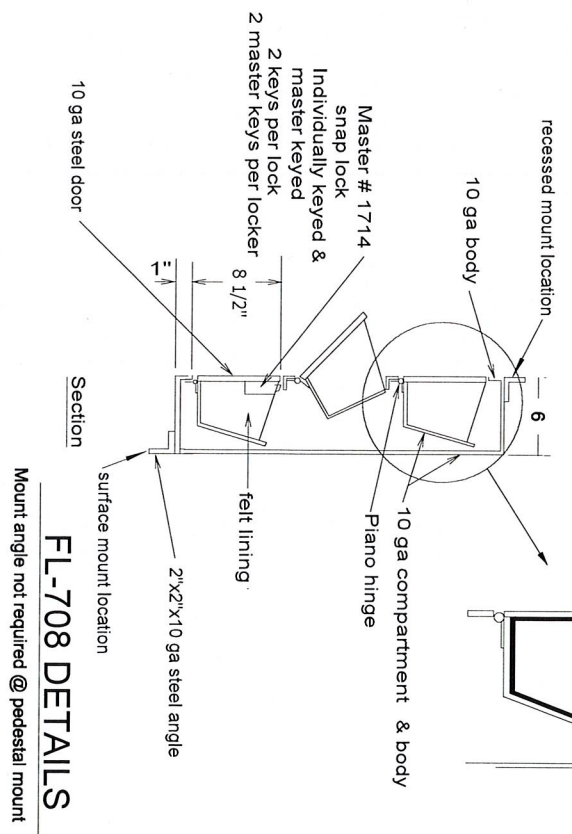

FL-708 DETAILS

Mount angle not required @ pedestal mount

Project	
Customer	
Drawn by	
Date	

FNSCO SECURITY PRODUCTS
 14522 Naples St 763-434-9841
 Ham Lake MN 55304 fax 763-208-0979



**49790 Bayside Ave.
Rush City, MN 55069
763-434-9841**

7/23/2020

Jason Caudillo
Mendocino County Sheriff's Office

RE: Outdoor pistol locker

Dear Jason,

We are pleased to provide you with the following price(s) regarding the standard products of Fasco Inc. will furnish only, the materials based on the following:

Scope of work:

Base bid includes the following items:

2-FL-708-10-WP Heavy duty Law Enforcement, tip out style pistol locker, 10 ga all welded steel construction, piano hinges, snap locks, individually keyed & master keyed, mount angle, zinc plate w/ powder coat finish, gasket lined doors
Pedestals included

Scope of work-

Base Bid _____ Dollars \$ 7,796.00 freight included; no tax

2. Standard warranty
 3. Freight allowed to jobsite
 4. F.O.B. jobsite
 5. Payment terms to be determined : credit approval, Visa or Mastercard
 6. Submittals & delivery will be based upon a mutually agreeable schedule
 7. Price subject to change after 60 days on raw materials. Fuel prices subject to increases after 30 days.
 8. Retainage not allowed on material only contracts
- B. All prices quoted exclude the following items.
- | | |
|-------------------------------------|------------------------------|
| 1. Unloading & storage of materials | 2. Installation |
| 3. Conduit & wire | 4. Anchors, unless specified |
| 5. Taxes | |

Thank you for considering us on this project. Please call me if you have any questions concerning this quote.
Sincerely,

Doug O'Brien
Fasco Inc.

ITEM 3g

Date of Meeting:	August 26, 2020
Contact:	Alyson Bailey P.M.
	Time Allocated for Item: 10 minutes

AGENDA TITLE: Measure B Project Management Report.

SUMMARY OF REQUEST / BACKGROUND INFORMATION:

Program

Staff and Infrastructure

Projects

CRT Phases and Timeline

BHRTC Phases and Timeline

PHF Phases and Timeline

Mental Health Treatment Act Citizens Oversight Committee

Mendocino County Behavioral Health

1120 S. Dora St. Ukiah, CA 95482

707.510-6637 or measureb@mendocinocounty.org

Minutes: Wednesday, July 22, 2020

AGENDA ITEM NO. 1 – CALL TO ORDER AND ROLL CALL (1:07 P.M.)

Committee Members Present: Mr. T. Allman; Dr. A. Barash; Mr. M. Mertle; Mr. L. Weer, Dr. J. Miller; Chair D. Moschetti; Vice Chair J. Diamond; Ms. S. Riley; and Mr. R. Liberty; Ms. C. Angelo; Ms. M. Feretta

Guests: Christian Curtis - County Council, Sheriff Kendall - Mendocino County , DeAnn Splinter and Eric Faddness - Nacht & Lewis

2:10 P.M. Vice Chair J. Diamond takes over meeting due to technical problems

2:28 P.M. Chair D. Moschetti resumes control of meeting

Exit: Vice Chair J. Diamond (3:42 P.M.); Mr. T. Allman (4:15 P.M.)

PUBLIC EXPRESSION ON NON-AGENDA ITEMS

None

3. COMMITTEE MATTERS

None

3a) Approval of Minutes of the June 24, 2020, Meeting

Presenter/s: Chair D. Moschetti

Public Comment: None

Committee Comment: Correct misspelling of “proceeds,” and emphasize required itemized invoices and financial statements by Contractor Sally Riley upon receipt of renewed County contract in June 24, 2020 minutes.

Committee Action: Upon motion by Mr. T. Allman, seconded by Ms. S. Riley, IT IS ORDERED that the Minutes for the June 24, 2020 meeting, are hereby approved barring

Mental Health Treatment Act Citizens Oversight Committee

Mendocino County Behavioral Health

1120 S. Dora St. Ukiah, CA 95482

707.510-6637 or measureb@mendocinocounty.org

Minutes: Wednesday, July 22, 2020

corrections specified above in Committee Comment.

Motion Passes with Ten approvals, and One Abstention

3b) Discussion of the Auditor's Expenditure Report on Measure B Tax Funds, and Estimates of Sales Tax Revenue

Presenter/s: Mr. L. Weer

Public Comment: Sherri Ebryum

Committee Comment: Ms. Shannon Riley questioned the addendum added: Measure B Budget. Chair D. Moschetti suggested that the budget join the agenda for August, and that questions may be answered by email to committee members who would like to know more about the budget between meetings.

Mr. T. Allman objected to bypassing the budget, and requested that more time be taken.

Mr. T. Allman makes an informal recommendation that the budget become a standing line item on each agenda going forward. Not seconded.

Chair D. Moschetti agrees to a brief question period.

Mr. L. Weer addresses Ms. S. Riley's questions regarding Special Program Expenses, Travel Out of County, and Operational Transfers (Expenses).

A budget report will be prepared for August; again, informal.

Committee Action: None

3c) Discussion and Possible Action Regarding the Kemper Ad Hoc Committee's Recommendations from the Collaboration on Funding for Service Gaps and Programs

Presenter/s: Dr. J. Miller, Ms. C. Angelo, Chair D. Mochetti

Mental Health Treatment Act Citizens Oversight Committee

Mendocino County Behavioral Health

1120 S. Dora St. Ukiah, CA 95482

707.510-6637 or measureb@mendocinocounty.org

Minutes: Wednesday, July 22, 2020

Public Comment: Jan Mcgourty, Sherri Ebryum, Bernie Norvel

ci) **Supportive Housing**

Committee Comment: Ms. S. Riley agrees with housing concern, but it feels that Measure B funds could have a better use since there are many housing grants available, and expressed concern regarding locating an appropriate agency to provide supportive services within a supportive housing model. Mr. T. Allman suggested that Measure B monies are tailored to working with matching grants, and that there may be a way to include outside monies that fit the program.

Vice Chair J. Diamond questioned the revisiting of services after so much controversy on the subject. Dr. J. Miller suggested that the change comes from analysis, not just through the Kemper Report, but by existing, working agencies in Mendocino County.

Ms. M. Feretta spoke to the preventative aspects of housing, as well as aftercare. This is why BHAB supported this particular item.

Mr. M. Mettle is concerned that the funding suggested would not be sufficient. Tax credits or other funds may lead to adequate funding. Measure B money is potential “seed money,” not necessarily all funding needed for the project, according to Dr. J. Miller.

Ms. R. Riley suggests that housing should be developed in conjunction with the jurisdiction of the proposed location to ensure project success.

She also suggests that Measure B money may be more powerful in providing the supportive service aspect of the housing proposal instead. Asks whether or not Project Homekey [a new funding initiative] would be appropriate?

Dr J. Miller explained that most services through supportive housing are billable and will not require Measure B dollars. Medi_Cal can be billed, which is why a service component is not detailed in the suggestion.

Mental Health Treatment Act Citizens Oversight Committee

Mendocino County Behavioral Health

1120 S. Dora St. Ukiah, CA 95482

707.510-6637 or measureb@mendocinocounty.org

Minutes: Wednesday, July 22, 2020

Mr. R. Liberty is against building and renovation at this time due to current costs.

Committee Action: Upon motion by Vice Chair J. Diamond, seconded by Ms. M. Feretta, IT IS ORDERED THAT the Mental Health Treatment Citizens Oversight Committee recommends to the Board of Supervisors that Measure B contributes a one-time allocation of One Million - Three Hundred Thousand dollars (\$1,300,000) to purchase and renovate or build permanent supportive housing for individuals on the coast who are homeless, chronically homeless, or at risk of chronic homelessness who have a mental health condition in addition to pursuing matching funds.

Yes, Mr. T. Allman/Yes, Dr. A. Barash/Yes, Mr. L. Weer/Yes, Dr. J. Miller/Yes, Chair D. Moschetti/Yes, Vice Chair J. Diamond/Yes, Mr. M. Mertle/No, Ms. S. Riley/No, Mr. R. Liberty/Yes, Ms. C. Angelo/Yes, Ms. M. Feretta

Motion Passes with Nine Approvals; Two Disapprovals

cii) **Community Education and Support**

Committee Comment: Ms. S. Riley questions as to whether or not the Behavioral Health Regional Training Center could be involved in implementing the service (it can).

Any agency should have to put forward a business plan, a way to implement it {the service}, and so would any other organization who took services on, under Measure B. All organizations would be paid only for services provided.

Mr. J Diamond asked Dr. J Miller if there was an agency within Mendocino County that she would recommend to provide the services being proposed. Dr. J Miller stated that she would recommend NAMI, as this is something NAMI does in other Counties.

Ms. C. Angelo is in support of NAMI championing the anti-stigma, outreach and education initiative if approved. An RFQ process would take on additional time and money.

Mental Health Treatment Act Citizens Oversight Committee

Mendocino County Behavioral Health

1120 S. Dora St. Ukiah, CA 95482

707.510-6637 or measureb@mendocinocounty.org

Minutes: Wednesday, July 22, 2020

Christian Curtis (County Council) plans to research whether or not a committee member who also represents a potentially eligible agency may both represent the committee and said agency while applying for the contract in question.

Committee Action: Upon motion by Vice Chair J. Diamond, seconded by Ms. C. Angelo, IT IS ORDERED that committee for Measure B recommend to the Board of Supervisors that a contract with an agency for community education and support in the amount of \$350,000 per year for four years (1.4 million dollars) and authorizing the Behavioral Health Director to award and sign-off on said contract

Yes, Mr. T. Allman/No, Dr. A. Barash/No, Mr. L. Weer/ Yes, Dr. J. Miller/Abstain, Chair D. Moschetti/Yes, Vice Chair J. Diamond/No, Mr. M. Mertle/Abstain, Ms. S. Riley/Yes, Mr. R. Liberty/Yes, Ms. C. Angelo/Yes, Ms. M. Feretta

Motion Passes with Six Approvals; Three Disapprovals; Two Abstentions

ciii) **Aftercare**

Committee Comment: Mr. T. Allman asked about service providers. It is explained that the potential funding would go to agencies that already provide aftercare to clients who are within the Specialty Mental Health network, allowing for out-of-network individuals to receive the same services.

Vice Chair J. Diamond questioned the number of people who would be served by this endeavor annually. The answer is approximately 140 clients who would otherwise be discharged from Crisis or hospitalization with no follow up. This provides for 60 days of aftercare services to allow for individuals to be provided with services as they are being linked to services within their insurance provider's network of care.

Though private insurers are supposed to provide mental health parity, they do not which is responsible for the problem, requiring the need for intervention.

Committee Action: Upon motion by Mr. T. Allman, seconded by Vice Chair J. Diamond, IT IS ORDERED that committee for Measure B recommend to the Board of Supervisors allocate

Mental Health Treatment Act Citizens Oversight Committee

Mendocino County Behavioral Health

1120 S. Dora St. Ukiah, CA 95482

707.510-6637 or measureb@mendocinocounty.org

Minutes: Wednesday, July 22, 2020

two-hundred sixty thousand dollars (\$260,000) per year for four (4) years (\$1,040,000 total) to provide follow-up services to all individuals not eligible for County services being discharged from a psychiatric hospital stay, receiving a 5150 crisis assessment

Yes, Mr. T. Allman/Yes, Dr. A. Barash/Yes, Mr. L. Weer/Yes, Dr. J. Miller/Yes, Chair D. Moschetti/Yes, Vice Chair J. Diamond/Yes, Mr. M. Mertle/Yes, Ms. S. Riley/Yes, Mr. R. Liberty/ Yes, Ms. C. Angelo/Yes, Ms. M. Feretta
Motion Passes Unanimously

civ) **Mobile Crisis Team**

Guest - Sheriff Kindall : Looking to adopt Butte County's model; Dual Response (an Officer with a Mental Health Rehab Specialist.)

Almost 40% of Mendocino County calls within one week have been Behavioral Health in nature.

Butte County has seen a: 33% decrease in 5150 criteria, 37% fewer ambulance transports to out-of-county services, and beneficial cross training between law enforcement and behavioral health. Confirmed that the Ukiah Chief of Police would also be interested in participating based on past conversation/s.

Committee Comment: Ms. S. Riley is concerned that the program will only be tested throughout the Sheriff's jurisdiction, and that the program/funding will not benefit the incorporated areas in Mendocino County, such as Ukiah, the largest tax and population base. Suggests allocating more funds. Strongly feels that the program should be rolled out countywide.

Dr. J. Miller explained that the pilot program is being recommended to start with the Sheriff's office partially because the more populous areas have crisis resources and hospitals, while citizens in the unincorporated areas are without crisis resources. She is also concerned about rolling out a huge program without a smaller trial and error phase.

Ms. M. Ferreta suggests using the Behavioral Health Regional Training Center as a place where multiple law enforcement and behavioral health agencies can learn and develop together.

Mental Health Treatment Act Citizens Oversight Committee

Mendocino County Behavioral Health

1120 S. Dora St. Ukiah, CA 95482

707.510-6637 or measureb@mendocinocounty.org

Minutes: Wednesday, July 22, 2020

Ms. S. Riley does not want to wait the suggested four years (the duration of the pilot) to further roll out this resource.

Mr. T. Allman suggests that the pilot program could be discussed more fluidly, and become a standing item on the committee's monthly agenda.

Christian Curtis, Esq. CC mentioned that Measure B does need to be cautious in wording when it comes to rolling out civic programs in collaboration with local government entities.

Committee Action: Upon motion by Ms. S. Riley, seconded by Mr. T. Allman, IT IS ORDERED that the Mental Health Treatment Act Citizens Oversight Committee recommends to the Board of Supervisors that they support the development of a Mobile Crisis Team in partnership with local law enforcement to be reviewed in six months and allocate Three Hundred Forty Thousand Dollars (\$340,000) per year for 4 years to fund three Mental Health Rehabilitation Specialist for the Mobile Crisis Team program.

Yes, Mr. T. Allman/Yes, Dr. A. Barash/Yes, Mr. L. Weer/Yes, Dr. J. Miller/Yes, Chair D. Moschetti/Yes, Vice Chair J. Diamond/Yes, Mr. M. Mertle/Yes, Ms. S. Riley/Yes, Mr. R. Liberty. Yes, Ms. C. Angelo/Yes, Ms. M. Feretta
Motion Passes Unanimously

3d) Discussion and Possible Action Regarding Estimated Proceeds, Facility Operating Costs (including Construction of the Crisis Residential Treatment Facility), and Renovation/Construction of an Acute Psychiatric Hospital or PHF

Presenter/s: Mr. L. Weer, Dr. J. Miller, Alyson Bailey P.M.

Public Comment: Jan Mcgourty

Committee Comment:

Mr. M. Mertle questions CHFFA funds and how they will be used?

Mental Health Treatment Act Citizens Oversight Committee

Mendocino County Behavioral Health

1120 S. Dora St. Ukiah, CA 95482

707.510-6637 or measureb@mendocinocounty.org

Minutes: Wednesday, July 22, 2020

Committee Action: None

3e) Discussion and Possible Action on Presentation by Nacht and Lewis on the Proposed Design, Site, and Floorplan of the Crisis Residential Treatment Facility, and Continuation of Construction/Project

Presenter/s: Alyson Bailey P.M., Guests DeAnn Splinter and Eric Fadness

Public Comment: Jan McGourty

Guest - Eric Fadness of Nacht & Lewis

Explained that the CRT project is ready to share with the Planning and Building of Mendocino County. Plans are at 95%. He provides a digital walkthrough of the project design.

The building has been designed to be prefabricated units due to speed and costs.

The outside of the building that will need to be completed.

Masonite and stucco will finish the house, and the roof will have standard concrete shingles.

There are double occupancy rooms for eight to ten residents, three bathrooms, laundry, discrete intake, quiet room, med room, storage, kitchen, and dining.

The building is completely ADA compliant.

Committee Comment: Mr. M. Mertle is concerned about not having certainty that operations are feasible, as is Mr. R. Liberty.

Dr. J. Miller explains that RFP for operations has already been written and is being prepared for release. She also explained that the CHFFA grant funding for \$500,000 will be pulled if the construction process is delayed.

Chair D. Moschetti pointed out that the CRT provides an alternative to the high level of care for clients like a PHFs

Mr. R. Liberty makes a motion to halt all construction on the CRT until the feasibility of affordable operations is determined.

Mental Health Treatment Act Citizens Oversight Committee

Mendocino County Behavioral Health

1120 S. Dora St. Ukiah, CA 95482

707.510-6637 or measureb@mendocinocounty.org

Minutes: Wednesday, July 22, 2020

Ms. C. Angelo is supportive of the spirit of the motion; suggests amendment.

No amendment. There is no second.

Ms. S. Riley agrees to move forward, but feels coerced into the decision because of pressure regarding the CHFFA grant.

Committee Action: Upon motion by Ms. M. Feretta, seconded by Dr. A. Barash, IT IS ORDERED that the committee for Measure B recommends that the Crisis Residential Treatment Facility project continue from the design phase to the Construction Management, and Construction phases for 3.7 million dollars.

Yes, Dr. A. Barash/Yes, Mr. L. Weer/Yes, Dr. J. Miller/Yes, Chair D. Moschetti/Yes, Mr. M. Mertle/Yes, Ms. S. Riley/No, Mr. R. Liberty/Yes, Ms. C. Angelo/Yes, Ms. M. Feretta
Motion Passes with Eight Approvals; One Disapproval; and Two Absences

3f) Discussion and Possible Action Regarding the Recommendation for Contracting with AECOM, Construction Management Services, for the CRT Project Concerning Pre-Construction and Contract Administration in the Amount of \$62,162 and \$269,676 Respectively

Presenter/s: Alyson Bailey P.M.

Public Comment: None

Committee Comment: Mr. M. Mertle asked about the Facility's RFI process and the number of bids. There were five qualified candidates. This is a Facility's contract for over five years; not just for Measure B.

The County does not have the staff to engage in Construction Management inhouse.

Committee Action: None (Informational)

Mental Health Treatment Act Citizens Oversight Committee

Mendocino County Behavioral Health

1120 S. Dora St. Ukiah, CA 95482

707.510-6637 or measureb@mendocinocounty.org

Minutes: Wednesday, July 22, 2020

4. COMMITTEE MEMBER REPORTS

None

5. ADJOURNMENT

THERE BEING NOTHING FURTHER, THE MENTAL HEALTH TREATMENT ACT CITIZENS OVERSIGHT COMMITTEE ADJOURNED AT 5:09 P.M.

Attest: Alyson Bailey

Committee Clerk

The Committee complies with ADA requirements and upon request, will attempt to reasonably accommodate individuals with disabilities by making meeting materials available in appropriate formats (pursuant to Government Code section 54953.2).

Anyone requiring reasonable accommodation to participate in the meeting should contact the Committee clerk by calling (707) 510-6637 at least five days prior to the meeting.

Additional information regarding the Committee may be obtained by referencing:
www.mendocinocounty.org/community/mental-health-oversight-committee