

James Feenan - Fwd: Public Comment for Use Permit No. U_2018-0022 continued public hearing on 12/12/19

From: PBS PBS
To: James Feenan; Caitlin Schafer; Keith Gronendyke
Date: 12/10/2019 2:27 PM
Subject: Fwd: Public Comment for Use Permit No. U_2018-0022 continued public hearing on 12/12/19
Attachments: Mendocino County TabA Standard Road Plans.pdf

Planning & Building Services Staff

County of Mendocino
Main Office:
860 N. Bush St, Ukiah CA 95482
Phone: [\(707\) 234-6650](tel:7072346650)
Coast Office:
120 W. Fir St, Fort Bragg CA 95437
Phone: [\(707\) 964-5379](tel:7079645379)
Web: www.co.mendocino.ca.us/planning/

Mendocino County
DEC 10 2019
Planning & Building Services

>>> Jacob Patterson <jacob.patterson.esq@gmail.com> 12/9/2019 9:01 PM >>>

I didn't see my comment added to Thursday's Zoning Administrator meeting packet online so I thought I would forward it again to make sure it in included.

----- Forwarded message -----

From: **Jacob Patterson** <jacob.patterson.esq@gmail.com>
Date: Thu, Dec 5, 2019 at 2:05 PM
Subject: Public Comment for Use Permit No. U_2018-0022 continued public hearing on 12/12/19
To: <gronendykek@mendocinocounty.org>

Keith,

Please include this public comment and add the attached Mendocino County Road Standards to the administrative record for Use Permit No. U_2018-0022. Mendocino County road standards were mentioned in the staff report and in prior public comments (e.g., that the access road is inadequate because it fails to meet current County standards for the intended uses) but the standards themselves were not included as supporting documentation.

Regards,

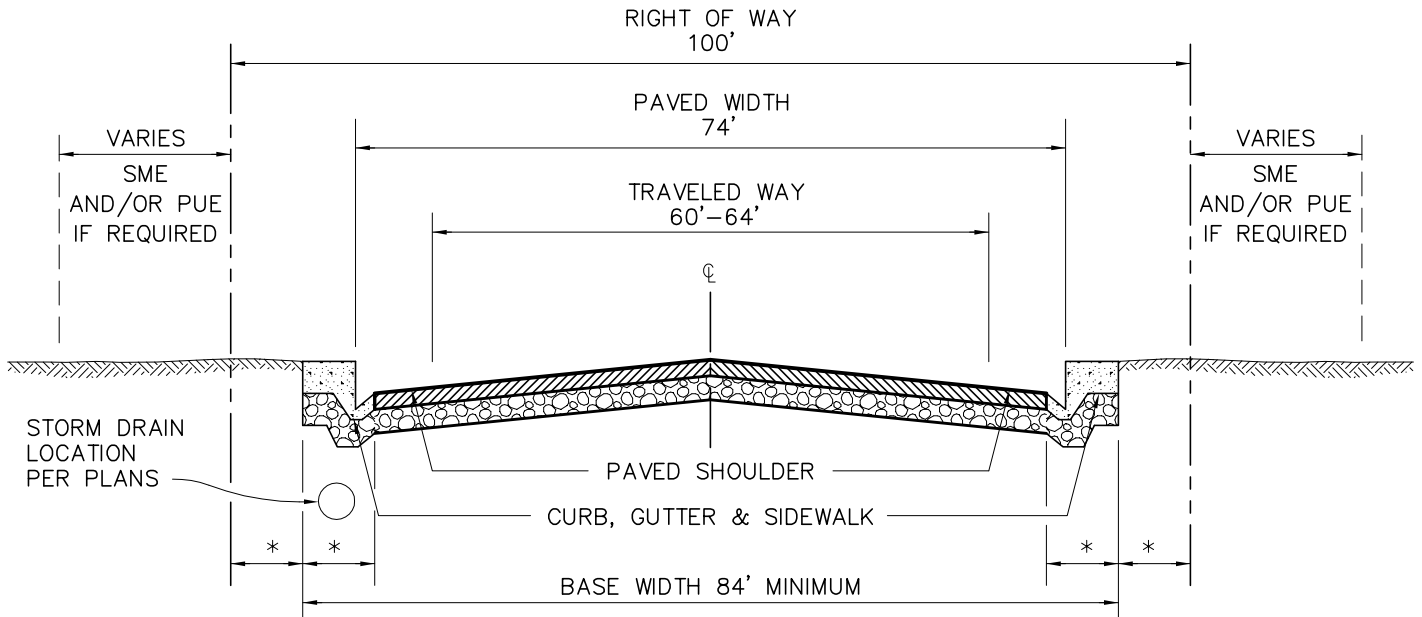

--Jacob

Tab A – Standard Plans



* = VARIES, SEE NOTE 5.

LEGEND:

-  PAVEMENT
-  BASE
- PUE PUBLIC UTILITY EASEMENT
- SME SLOPE MAINTENANCE EASEMENT

NOTES:

1. PARKING GENERALLY PROHIBITED. PAVED SHOULDER TO SERVE AS BIKEWAY AND/OR EMERGENCY STOPPING AREA.
2. RIGHT OF WAY BEHIND SIDEWALK MAY BE USED FOR ROADSIDE FACILITIES SUCH AS SIGNS, PUBLIC UTILITIES, LANDSCAPING AND DRAINAGE FACILITIES.
3. BASED ON THE RECOMMENDATION OF THE DOT DIRECTOR AND SUBJECT TO THE APPROVAL AUTHORITY, THE MINIMUM PAVED WIDTH OF MINOR ARTERIAL AND MAJOR COLLECTOR URBAN ROADS MAY BE REDUCED BY 12'-14' WHERE CENTER TURN LANES OR MEDIANS ARE NOT REQUIRED.
4. BASED ON THE RECOMMENDATION OF THE DOT DIRECTOR AND SUBJECT TO THE APPROVAL AUTHORITY, THE MINIMUM PAVED WIDTH OF MINOR ARTERIAL AND MAJOR COLLECTOR URBAN ROADS MAY BE REDUCED BY UP TO 24 FEET WHERE FOUR TRAVEL LANES ARE NOT REQUIRED.
5. SEE MENDOT STD. NO. A40A FOR CURB, GUTTER AND SIDEWALK DETAILS.



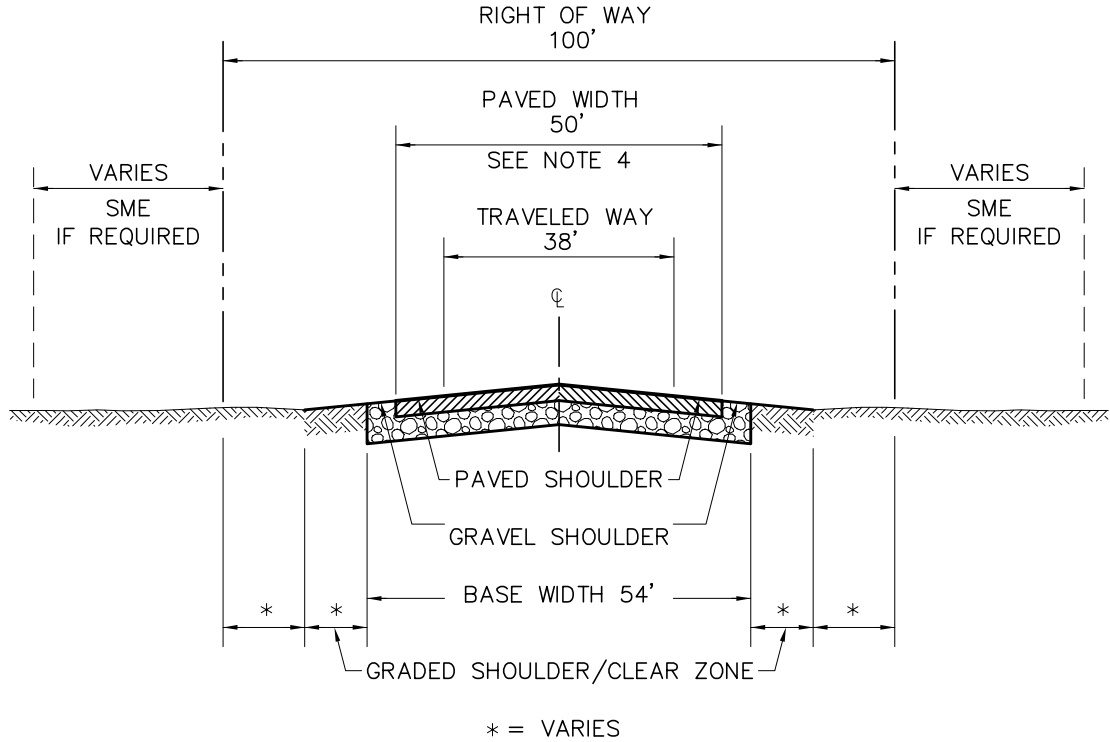

MINOR ARTERIAL AND MAJOR COLLECTOR – URBAN TYPICAL ROAD SECTION

MENDOT STD. NO. **A10A**



LEGEND:

-  PAVEMENT
-  BASE
-  COMPACTED EARTH
- SME SLOPE MAINTENANCE EASEMENT

NOTES:

1. PARKING MAY BE PROHIBITED. PAVED SHOULDER TO SERVE AS BIKEWAY AND WALKWAY.
2. GRADED SHOULDER MAY BE USED FOR ADDITIONAL CLEAR ZONE IF REQUIRED.
3. RIGHT OF WAY OUTSIDE OF CLEAR ZONE MAY BE USED FOR ROADSIDE FACILITIES SUCH AS TURNOUTS, SIGNS, ROADSIDE VEGETATION, PUBLIC UTILITIES AND DRAINAGE FACILITIES.
4. BASED ON THE RECOMMENDATION OF THE DOT DIRECTOR, AND SUBJECT TO THE APPROVAL AUTHORITY, THE MINIMUM PAVED WIDTH OF MINOR ARTERIAL RURAL ROADS MAY BE REDUCED BY UP TO 14' WHERE CENTER TURN LANES OR MEDIANS ARE NOT REQUIRED.
5. SEE MENDOT STD. A18 FOR ROAD GRADING SECTIONS.



**MINOR ARTERIAL – RURAL
TYPICAL ROAD SECTION**

MENDOT
STD. NO.
A10B

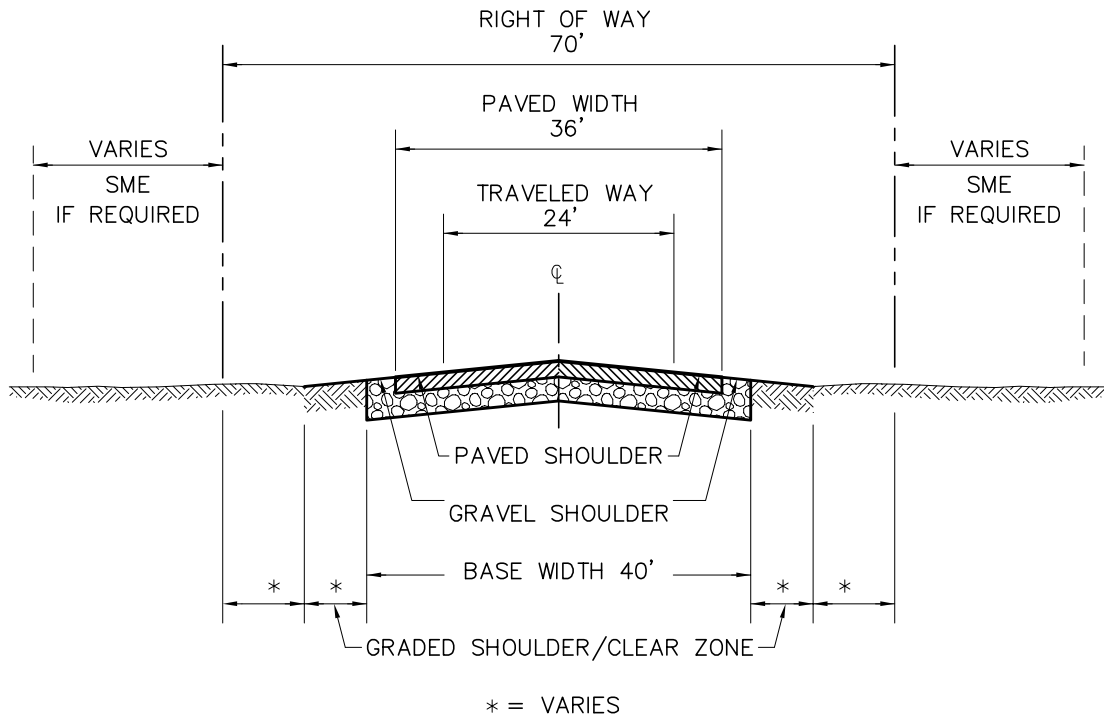

LEGEND:

- PAVEMENT
- BASE
- COMPACTED EARTH
- SME SLOPE MAINTENANCE EASEMENT

NOTES:

1. PARKING MAY BE PROHIBITED. PAVED SHOULDER TO SERVE AS BIKEWAY AND WALKWAY.
2. GRADED SHOULDER MAY BE USED FOR ADDITIONAL CLEAR ZONE IF REQUIRED.
3. RIGHT OF WAY OUTSIDE OF CLEAR ZONE MAY BE USED FOR ROADSIDE FACILITIES SUCH AS TURNOUTS, SIGNS, ROADSIDE VEGETATION, PUBLIC UTILITIES AND DRAINAGE FACILITIES.
4. SEE MENDOT STD. A18 FOR ROAD GRADING SECTIONS.



**CONNECTORS, MAJOR AND MINOR
COLLECTORS, AND LOCAL CONNECTORS—RURAL
TYPICAL ROAD SECTION**

MENDOT
STD. NO.
A10C

SCALE: NONE

DESIGN: RCW

DRAWN: LMM

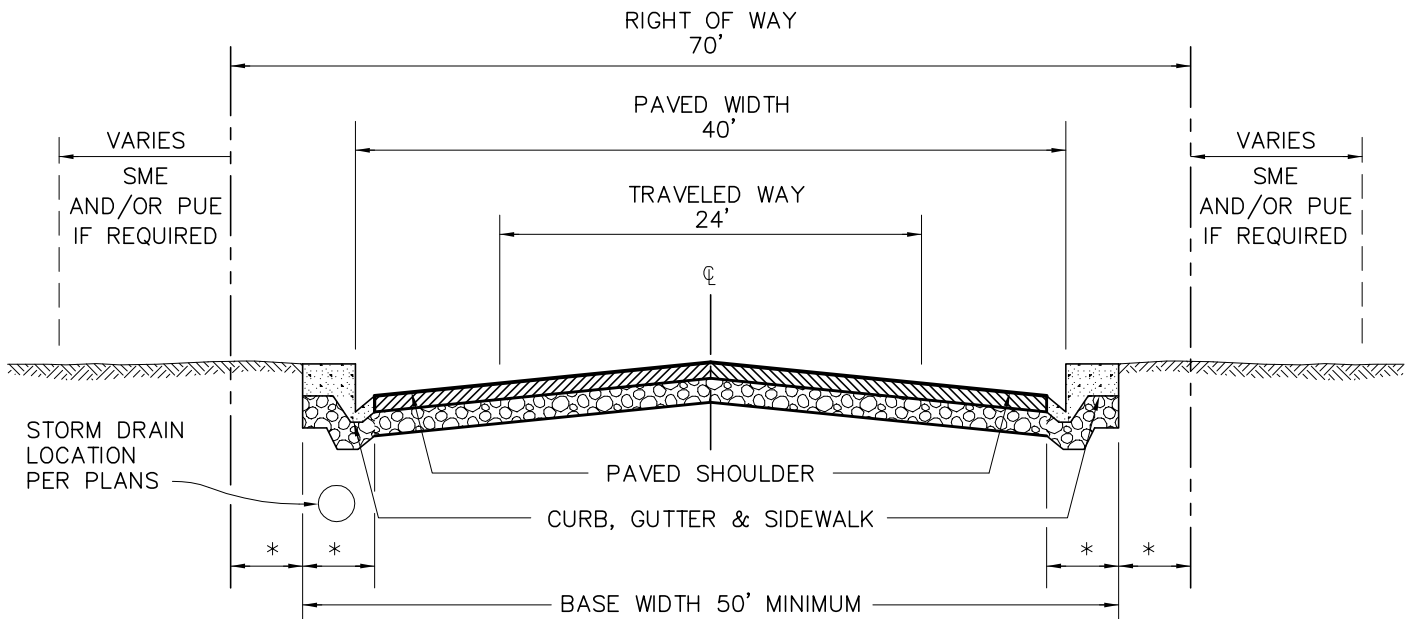

OCT. 2000

PAGE: A-3



* = VARIES, SEE NOTE 3.

LEGEND:

-  PAVEMENT
-  BASE
- PUE PUBLIC UTILITY EASEMENT
- SME SLOPE MAINTENANCE EASEMENT

NOTES:

1. PAVED SHOULDER TO SERVE AS PARKING LANE AND/OR BIKEWAY.
2. RIGHT OF WAY BEHIND SIDEWALK MAY BE USED FOR ROADSIDE FACILITIES SUCH AS SIGNS, PUBLIC UTILITIES, LANDSCAPING AND DRAINAGE FACILITIES.
3. SEE MENDOT STD. NO. A40A FOR CURB, GUTTER AND SIDEWALK DETAILS.



**MINOR COLLECTOR, LOCAL CONNECTOR
URBAN
TYPICAL ROAD SECTION**

MENDOT
STD. NO.
A10D

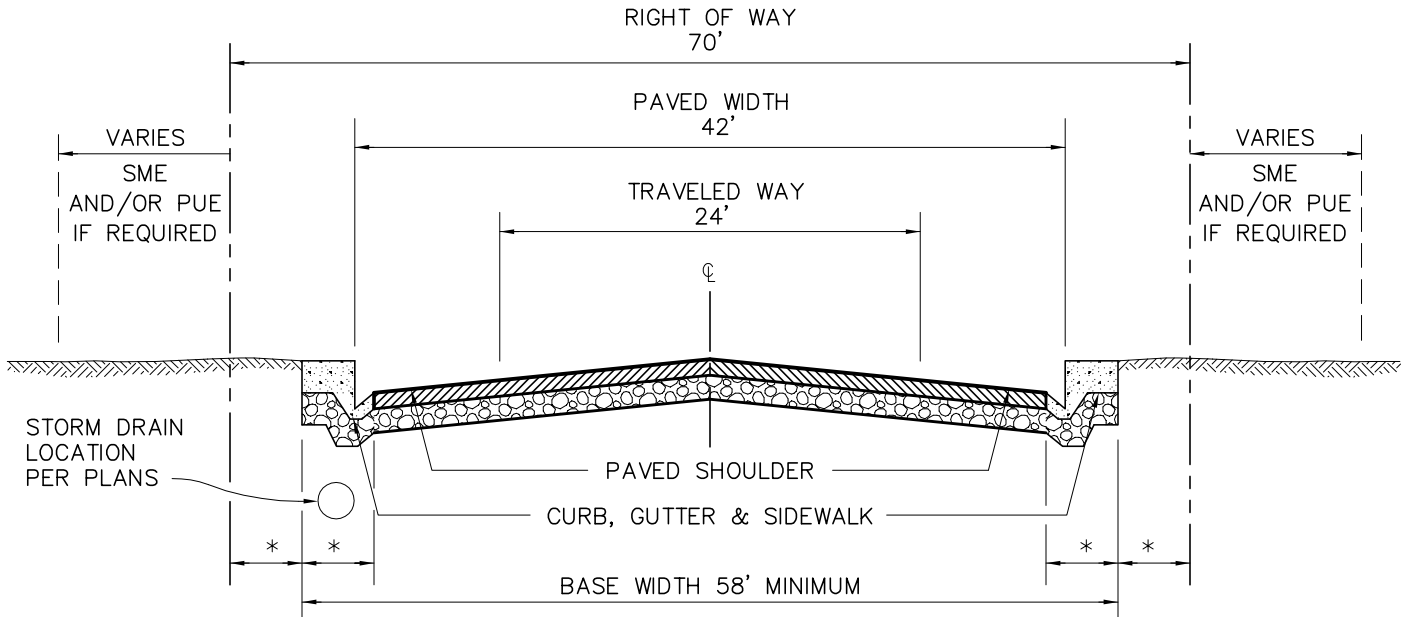

SCALE: NONE | DESIGN: RCW | DRAWN: CLG | OCT. 2000

PAGE: A-4



* = VARIES, SEE NOTE 3.

LEGEND:

-  PAVEMENT
-  BASE
- PUE PUBLIC UTILITY EASEMENT
- SME SLOPE MAINTENANCE EASEMENT

NOTES:

1. PAVED SHOULDER TO SERVE AS PARKING LANE AND/OR BIKEWAY.
2. RIGHT OF WAY BEHIND SIDEWALK MAY BE USED FOR ROADSIDE FACILITIES SUCH AS SIGNS, PUBLIC UTILITIES, LANDSCAPING AND DRAINAGE FACILITIES.
3. SEE MENDOT STD. NO. A40A FOR CURB, GUTTER AND SIDEWALK DETAILS.



LOCAL ROAD, COMMERCIAL OR INDUSTRIAL URBAN TYPICAL ROAD SECTION

MENDOT STD. NO. **A10E**

SCALE: NONE | DESIGN: RCW | DRAWN: CLG | OCT. 2000

PAGE: A-5

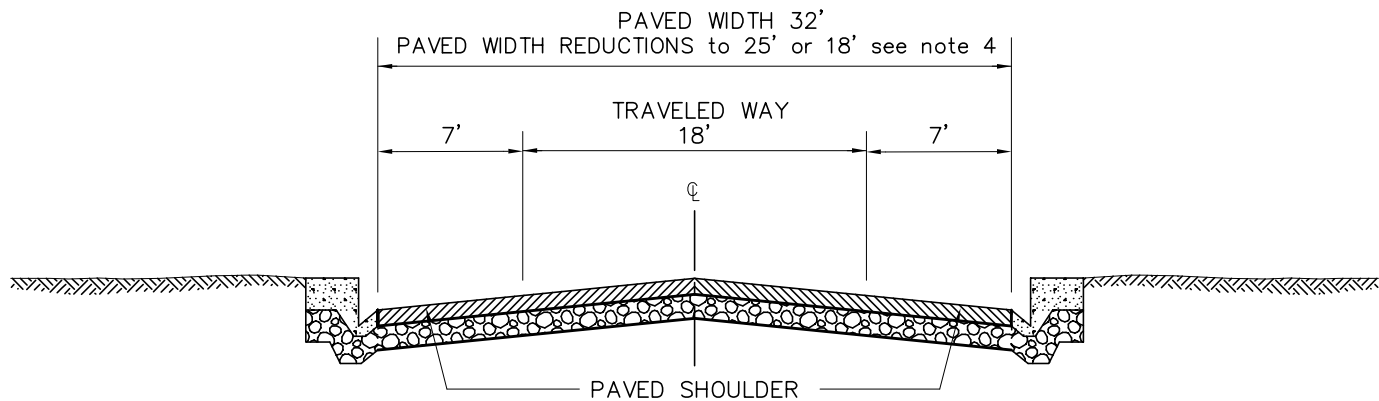

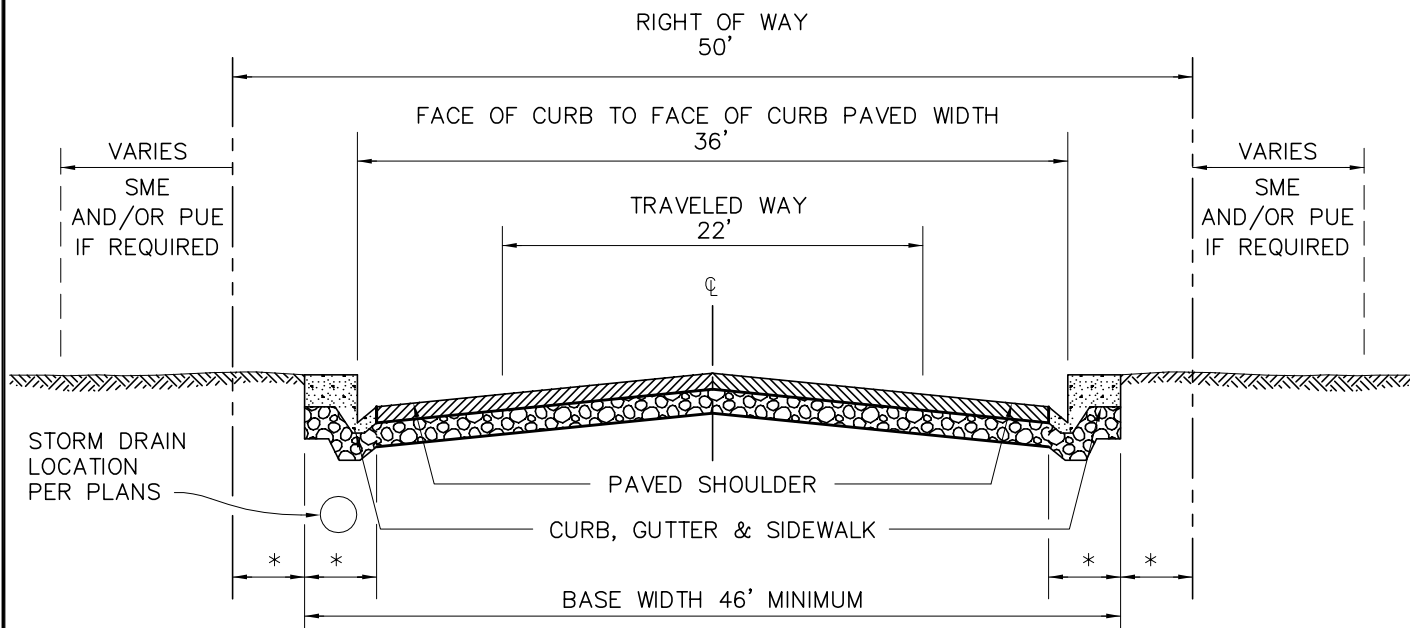

REDUCED

Details not shown
same as standard



STANDARD

LEGEND:

-  PAVEMENT
-  BASE
- PUE PUBLIC UTILITY EASEMENT
- SME SLOPE MAINTENANCE EASEMENT
- * = VARIES, SEE NOTE 3.

NOTES:

1. PAVED SHOULDER TO SERVE AS PARKING LANE WHERE PARKING IS PERMITTED.
2. RIGHT OF WAY BEHIND SIDEWALK MAY BE USED FOR ROADSIDE FACILITIES SUCH AS SIGNS, PUBLIC UTILITIES, LANDSCAPING AND DRAINAGE FACILITIES.
3. SEE MENDOT STD. NO. A40A FOR CURB, GUTTER AND SIDEWALK DETAILS.
4. SEE MENDOT STD. TAB(S) C.3.H & H CONCERNING WIDTH REDUCTIONS RELATED TO NO STREET PARKING.



LOCAL ROAD, RESIDENTIAL AND URBAN TYPICAL ROAD SECTION

MENDOT STD. NO. **A10F**

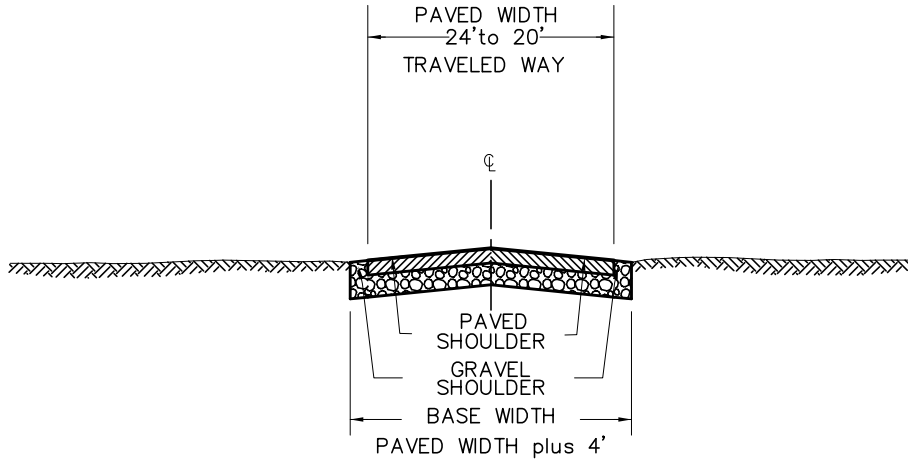

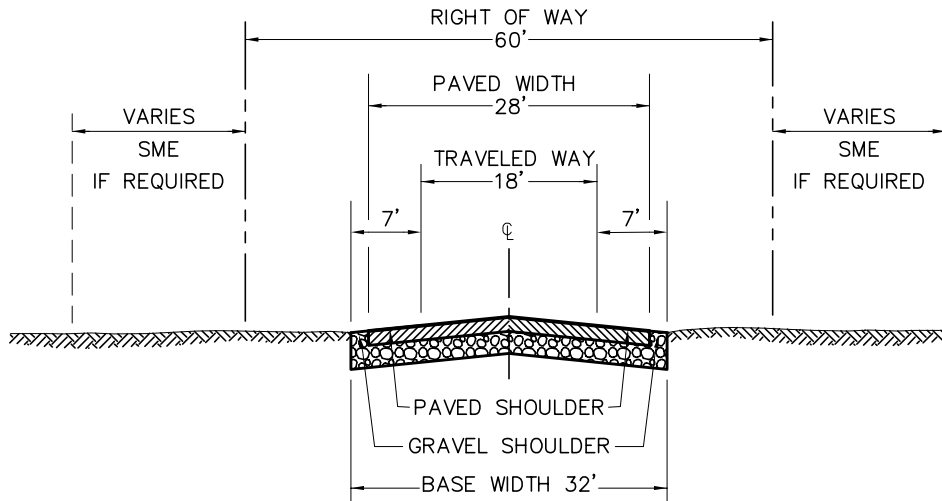

REDUCED

Details not shown
same as STANDARD



STANDARD

LEGEND:

-  PAVEMENT
-  BASE
- SME SLOPE MAINTENANCE EASEMENT

NOTES:

1. PARKING MAY BE PROHIBITED. PAVED SHOULDER TO SERVE AS BIKEWAY AND WALKWAY.
2. RIGHT OF WAY OUTSIDE OF SHOULDER MAY BE USED FOR ROADSIDE FACILITIES SUCH AS TURNOUTS, SIGNS, ROADSIDE VEGETATION, PUBLIC UTILITIES AND DRAINAGE FACILITIES.
3. SEE MENDOT STD. A18 FOR ROAD GRADING SECTIONS.
4. SEE MENDOT STD. TAB(s) C.3.H & H FOR REDUCED WIDTH.



LOCAL ROAD — RURAL TYPICAL ROAD SECTION



MENDOT
STD. NO.
A10G

SCALE: NONE | DESIGN: HND | DRAWN: HND | AUG. 2004

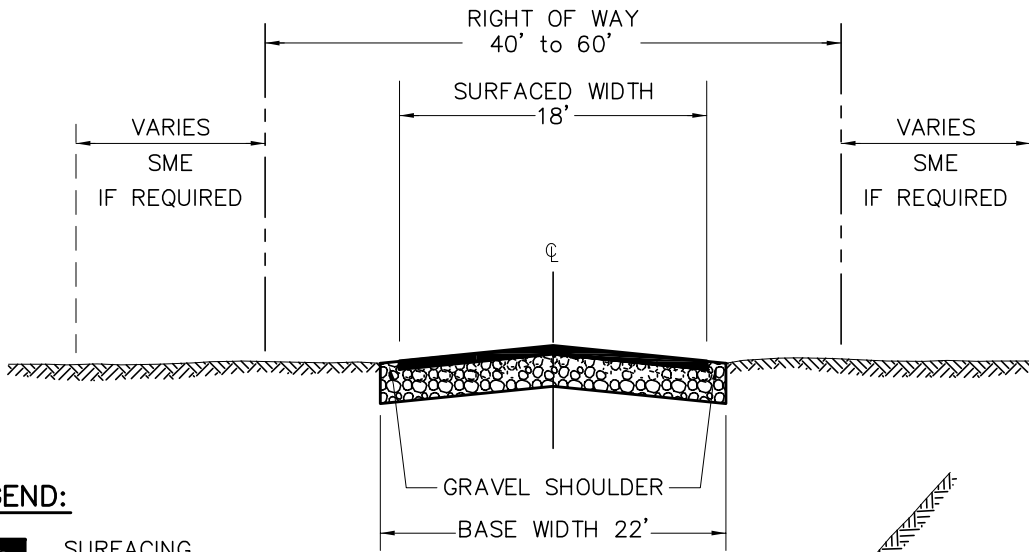
PAGE: A-7



LEGEND:

-  SURFACING
-  BASE
- SME SLOPE MAINTENANCE EASEMENT

2:1 or flatter unless approved by engineer

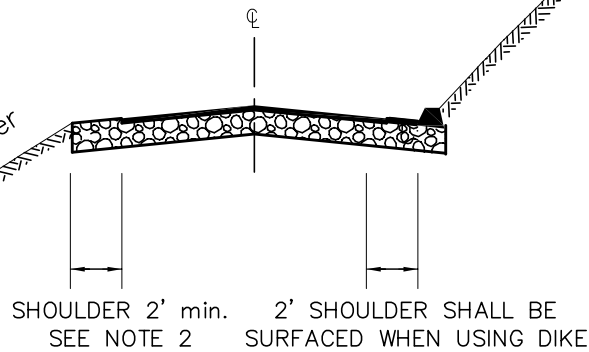

NOTES:

1. PARKING MAY BE PROHIBITED. PAVED SHOULDER TO SERVE AS BIKEWAY AND WALKWAY.
2. RIGHT OF WAY OUTSIDE OF SHOULDER MAY BE USED FOR ROADSIDE FACILITIES SUCH AS TURNOUTS, SIGNS, ROADSIDE VEGETATION, PUBLIC UTILITIES AND DRAINAGE FACILITIES.
3. SEE MENDOT STD. A18 FOR ROAD GRADING SECTIONS.
4. MINIMUM EASEMENT WIDTH SHALL BE 60' WHEN THE ROAD SERVES, OR HAS THE POTENTIAL TO SERVE, MORE THAN 4 LOTS.
5. A STRUCTURAL SECTION DESIGNED WITH A MINIMUM TI 4.5 SHALL BE PROVIDED PER SEC. C.3.S. OTHERWISE, MINIMUM IMPROVEMENT LEVELS FOR NON CONTINUOUS ROADS SHALL BE DEFINED AS FOLLOWS:

PROFILE GRADE	BASE WIDTH	BASE THICKNESS	SURFACING	SURFACING WIDTH
<16%	22'	14"	NONE	NONE
<20%>16%	22'	14"	DOUBLE CHIP SEAL	18'
<20%>16%	22'	9"	2.5" AC min.	18'



**LOCAL ROAD – NON CONTINUOUS
TYPICAL ROAD SECTION**

MENDOT
STD. NO.
A10G1

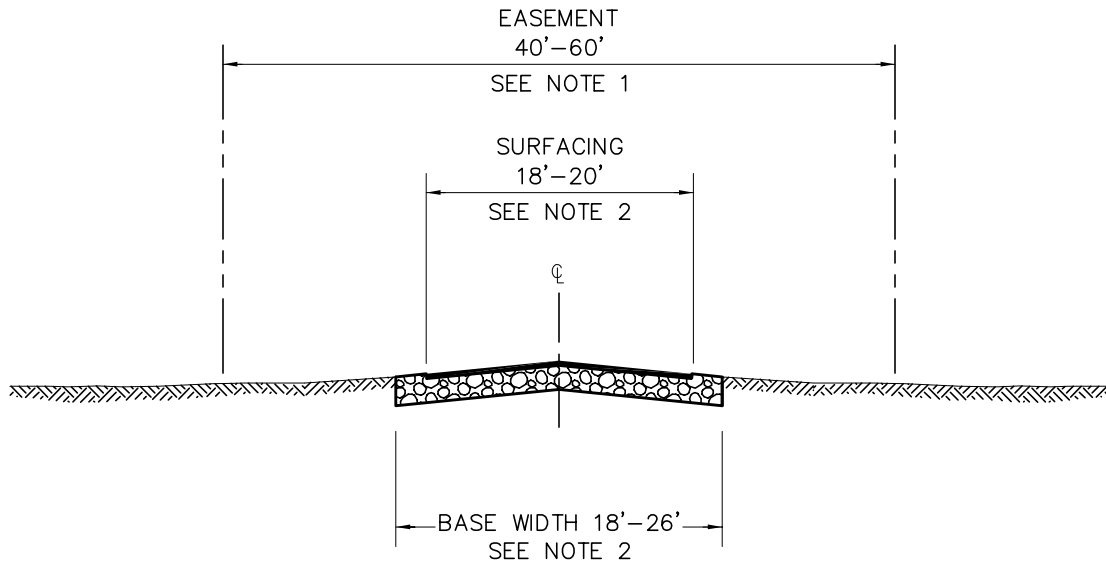

LEGEND:

- SURFACING
- ▨ BASE

NOTES:

1. MINIMUM EASEMENT WIDTH SHALL BE 60' WHEN THE ROAD SERVES, OR HAS THE POTENTIAL TO SERVE, MORE THAN 4 LOTS.
2. IMPROVEMENT LEVELS FOR PRIVATE ROADS SHALL BE DEFINED AS FOLLOWS:

IMPROVEMENT LEVEL	BASE WIDTH	BASE THICKNESS	SURFACING	SURFACING WIDTH
A	22' 8" or Design*	NONE	NONE	NONE
B	22' 12" or Design*	DOUBLE CHIP SEAL	18'	
C	26' 8" or Design*	NONE	NONE'	
D	26' 12" or Design*	DOUBLE CHIP SEAL	20'	

* Structural section thickness may be reduced based on soil "R" value and TI = 4.5, per C.3.S. "Pavement Design"

3. SEE ROAD DESIGN STANDARDS, TAB C, FOR THE REQUIRED IMPROVEMENT LEVELS FOR PRIVATE MINOR SUBDIVISION ROADS.
4. SEE MENDOT A18 FOR ROAD GRADING SECTIONS. ONLY TYPICAL SECTIONS "A" AND "B" SHALL BE USED FOR PRIVATE ROADS.



**PRIVATE
MINOR SUBDIVISION ROAD
TYPICAL ROAD SECTION**

MENDOT
STD. NO.
A10H

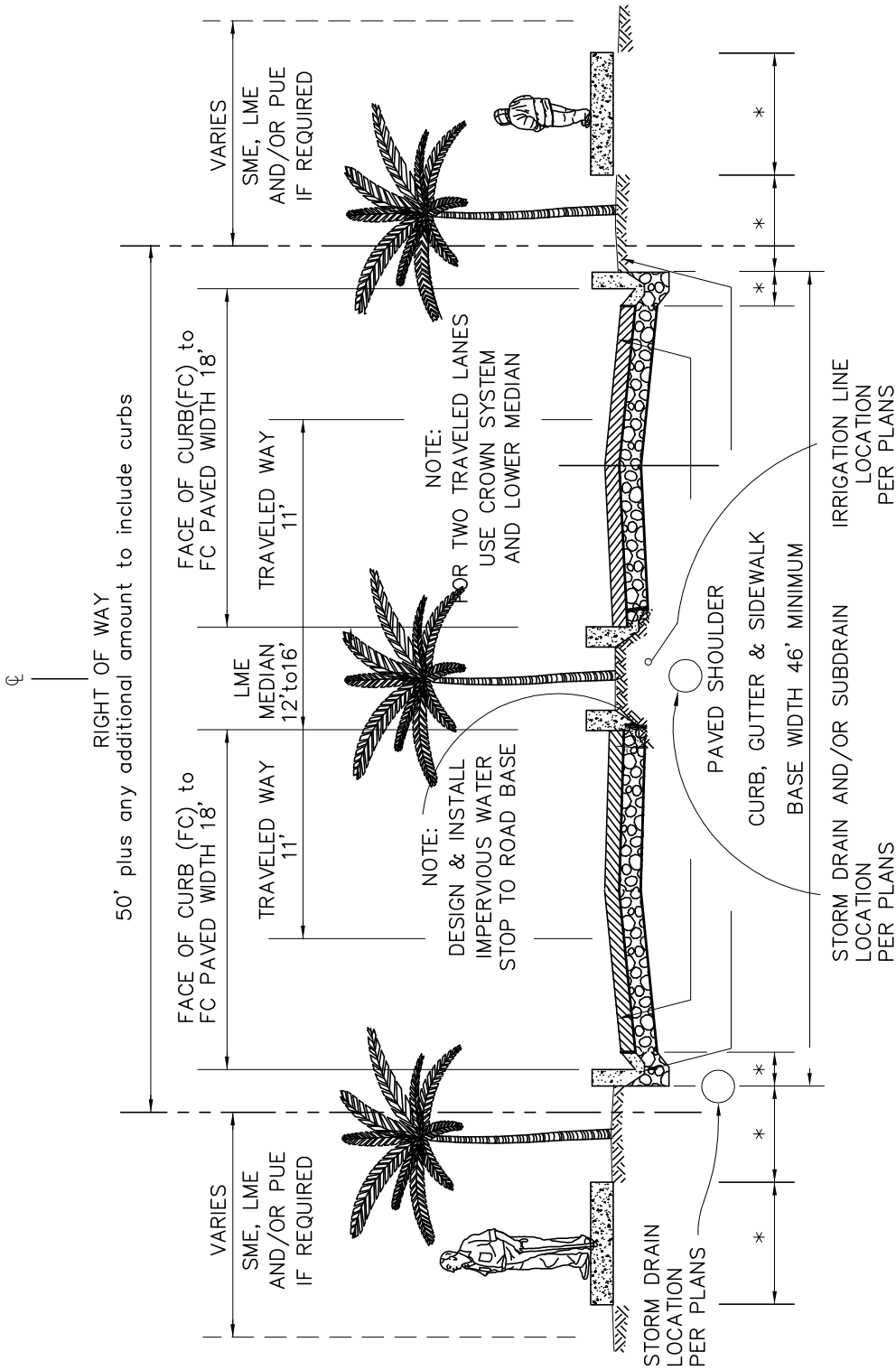

NOTES:

1. PAVED SHOULDER TO SERVE AS PARKING LANE WHERE PARKING IS PERMITTED.
2. RIGHT OF WAY BEHIND SIDEWALK MAY BE USED FOR ROADSIDE FACILITIES SUCH AS SIGNS, PUBLIC UTILITIES, LANDSCAPING AND DRAINAGE FACILITIES.
3. SEE MENDOT STD. NO. A40A FOR CURB, GUTTER, SIDEWALK, & MEDIAN LANDSCAPE MAINTENANCE DETAILS.
4. SEE MENDOT STD. TAB(S) C.3.H & H CONCERNING WIDTH REDUCTIONS RELATED TO NO STREET PARKING.

LEGEND:

- PAVEMENT
- BASE
- PUE
- SME
- LME

* = VARIES, SEE NOTE 3.



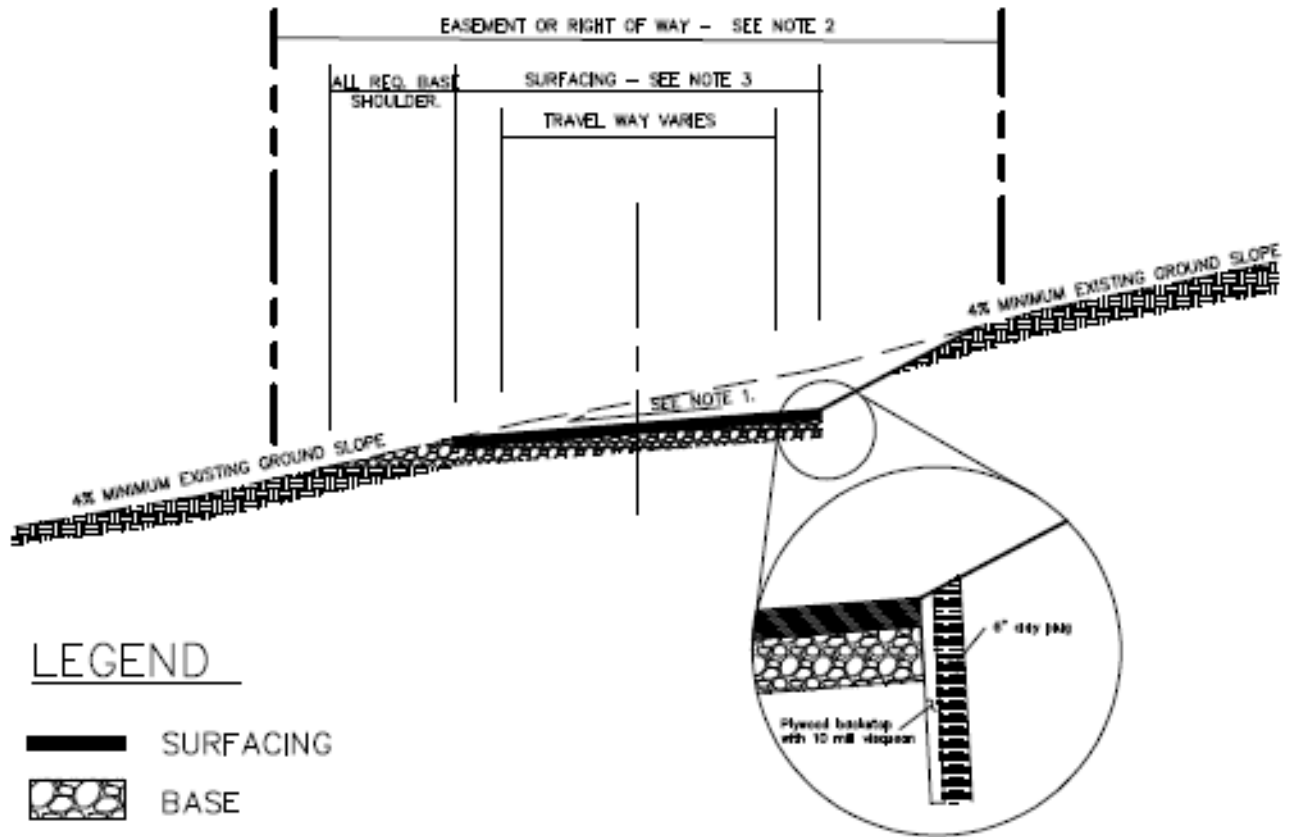

**LANDSCAPED LOCAL ROAD
HEALTHY NEIGHBORHOOD RESIDENTIAL
URBAN STREET DESIGN EXCEPTIONS**

MENDOT
STD. NO.
A10I



LEGEND

-  SURFACING
-  BASE

SEE Note 5. Water Barrier

NOTES:

1. DESIGN OF CROSS SLOPE SHALL CONFORM TO Tab C_d - Alternate Design Standards.
2. MINIMUM PRIVATE EASEMENT OR PUBLIC RIGHT OF WAY WIDTH SHALL CONFORM TO THE ROAD DESIGNATION.
3. SURFACING WIDTH SHALL CONFORM TO THE APPROPRIATE STD. NOS. A10G & H; HOWEVER FULL SHOULDER WIDTH MUST ALL BE PLACED ON THE OUTSLOPED PORTION.
4. PAVEMENT AND/OR BASE THICKNESS' SHALL CONFORM TO THE REQUIRED ROAD DESIGNATION.
5. DEVELOPERS DESIRING TO USE THIS ALTERNATE STANDARD SHALL PROVIDE A WATER BARRIER UNLESS THE PROJECT SOILS INVESTIGATION INDICATES THAT SUBSOIL WATER WILL NOT MIGRATE INTO THE BASE LAYER IN SUFFICIENT AMOUNTS TO CAUSE PAVEMENT DAMAGE.



**LOW IMPACT TO HYDROLOGY
GUIDELINES / ALTERNATE
DESIGN STANDARDS**

MENDOT
STD. NO.
A10J

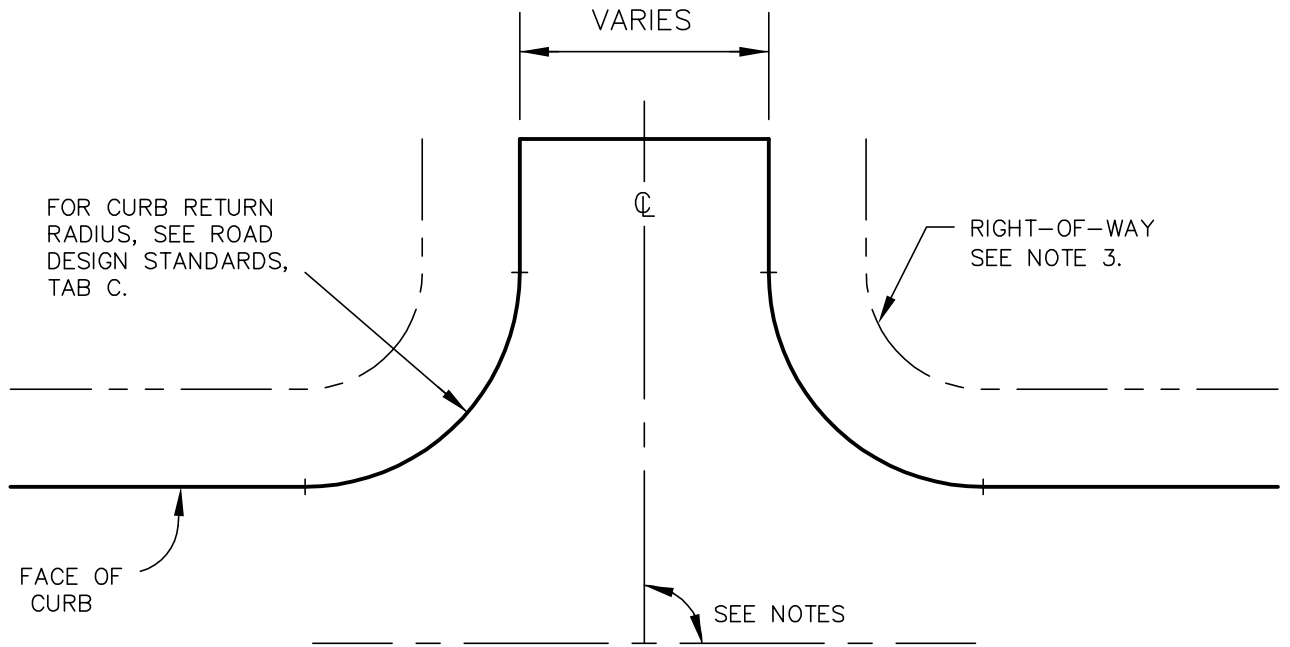

INTERSECTION "A"

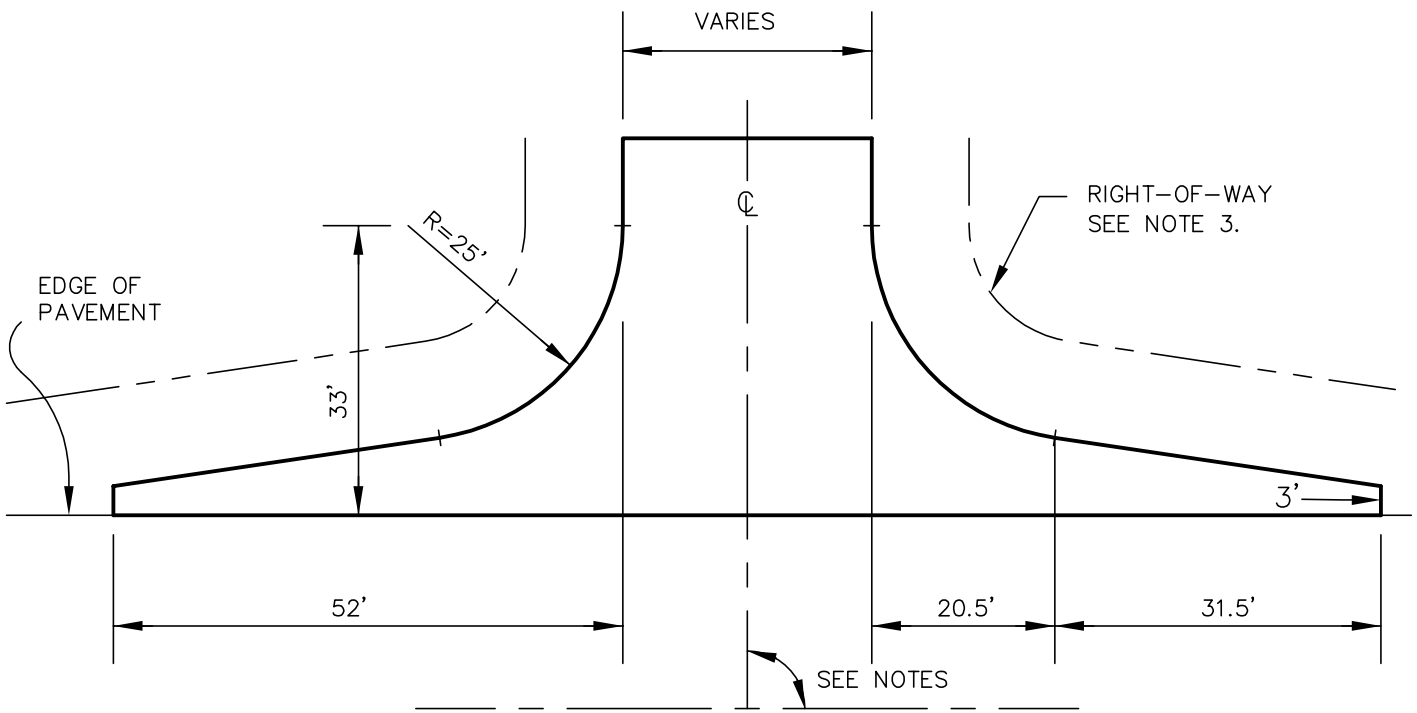

INTERSECTION "B"

NOTE: SEE INTERSECTION GEOMETRY NOTES ON STD. A11B.



INTERSECTION GEOMETRY

MENDOT
STD. NO.
A11A

NOTES:

1. INTERSECTIONS WITH ARTERIAL ROADS SHALL BE DESIGNED ON A CASE-BY-CASE BASIS.
2. INTERSECTION GEOMETRY FOR OTHER ROADS SHALL BE BASED ON THE FOLLOWING TABLE:

ROAD CLASSIFICATION	URBAN MAJOR COLLECTOR	RURAL MAJOR COLLECTOR/ CONNECTOR/ MINOR COLLECTOR	URBAN MINOR COLLECTOR	URBAN LOCAL	RURAL LOCAL/ PRIVATE ROAD
URBAN MAJOR COLLECTOR	A				
RURAL MAJOR COLLECTOR/ CONNECTOR/ MINOR COLLECTOR	A	B			
URBAN MINOR COLLECTOR	A	A	A		
URBAN LOCAL	A	B	A	A	
RURAL LOCAL/ PRIVATE ROAD	A	B	A	A	B

3. RIGHT-OF-WAY LINES AT EACH INTERSECTION SHALL BE ROUNDED.
4. A GREATER RETURN RADIUS MAY BE REQUIRED IF ROADS INTERSECT AT OTHER THAN RIGHT ANGLES.

NOTE: SEE INTERSECTION GEOMETRY ON STD. A11A.



**INTERSECTION GEOMETRY
NOTES**

MENDOT
STD. NO.
A11B

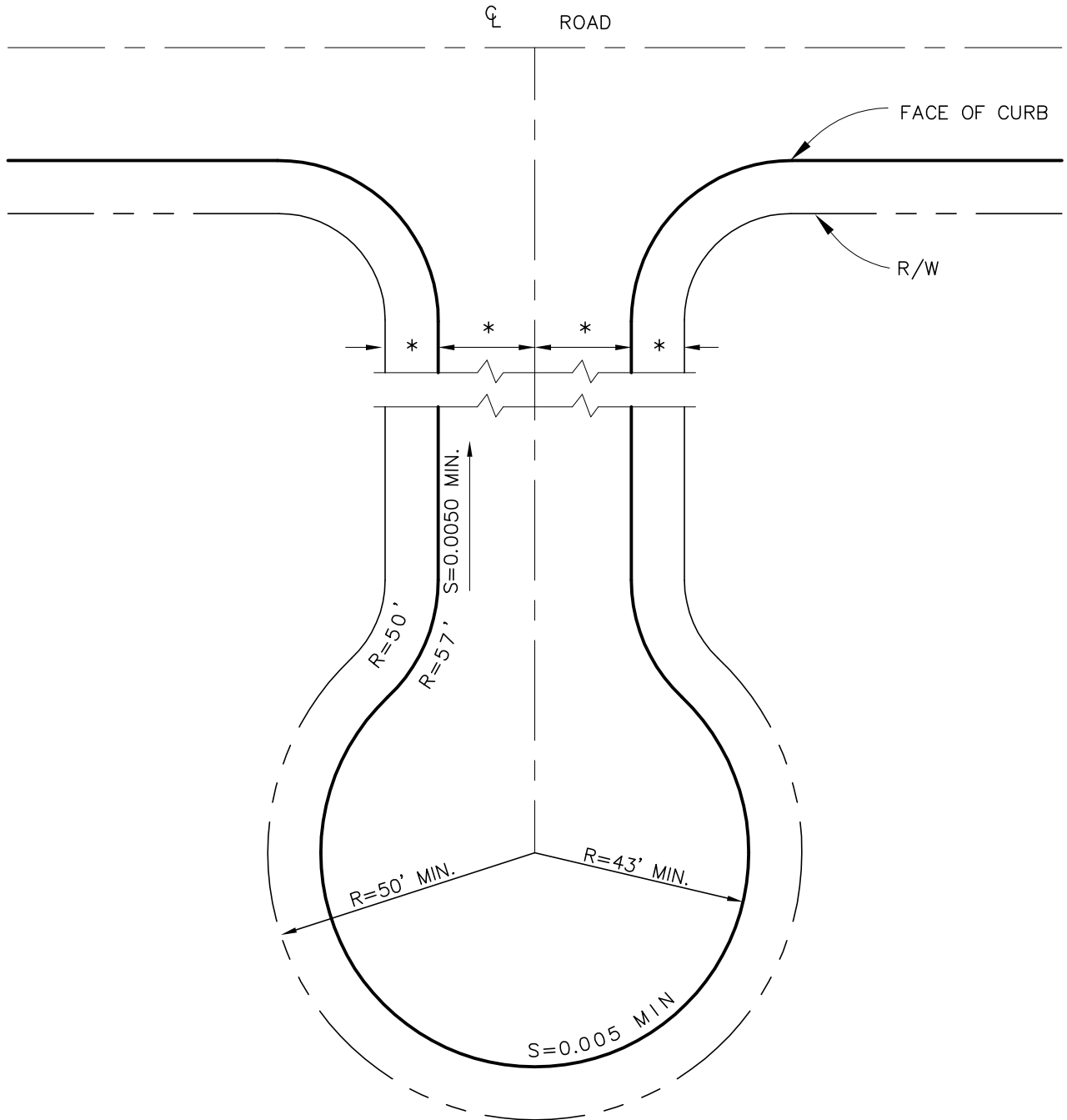

CROSS SLOPE IN BULB AREA SHALL BE MIN 2%

* VARIES. SEE ROAD CLASSIFICATIONS



URBAN CUL-DE-SAC

MENDOT STD. NO. **A12**

SCALE: NONE

DESIGN: RCW

DRAWN: LMM

OCT. 2000

PAGE: A-11

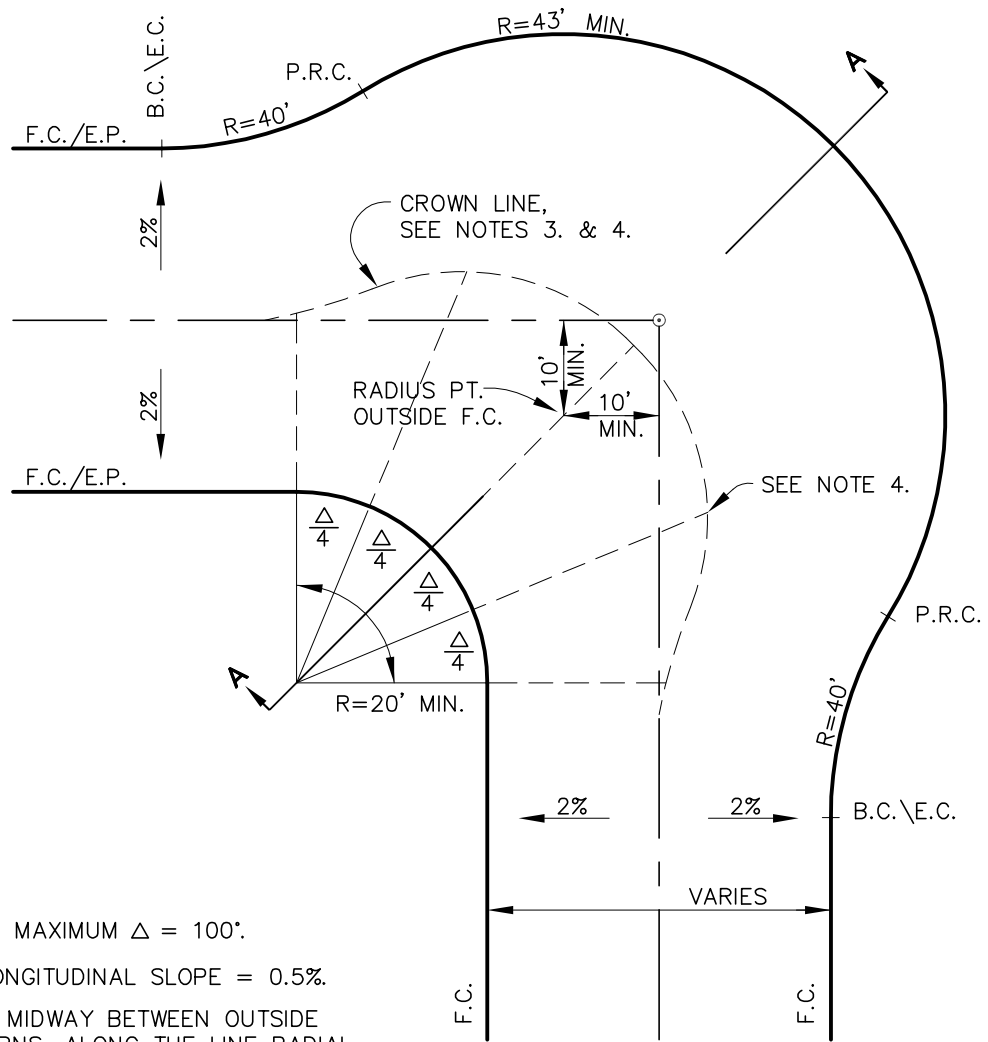

NOTES:

1. MINIMUM $\Delta = 60^\circ$; MAXIMUM $\Delta = 100^\circ$.
2. MINIMUM CURB LONGITUDINAL SLOPE = 0.5%.
3. CROWN LINE LIES MIDWAY BETWEEN OUTSIDE AND INSIDE RETURNS, ALONG THE LINE RADIAL TO INSIDE RETURN.
4. CROWN LINE ELEVATION TO BE SHOWN ON THE PLANS AT $\Delta/4$ POINTS.

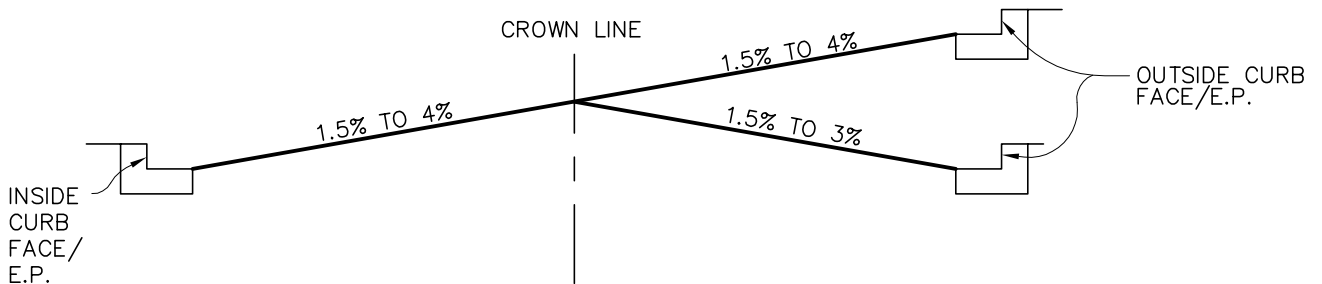

SECTION A-A
MAXIMUM & MINIMUM CROSS SLOPES



ROAD KNUCKLE

MENDOT
STD. NO.
A13

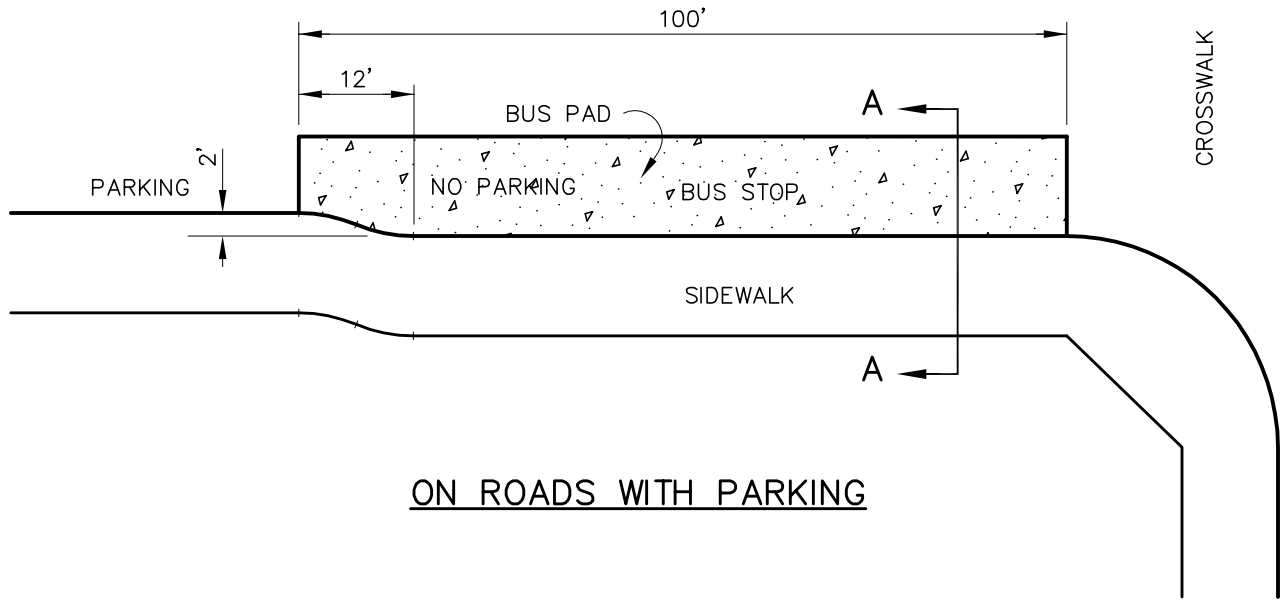

ON ROADS WITH PARKING

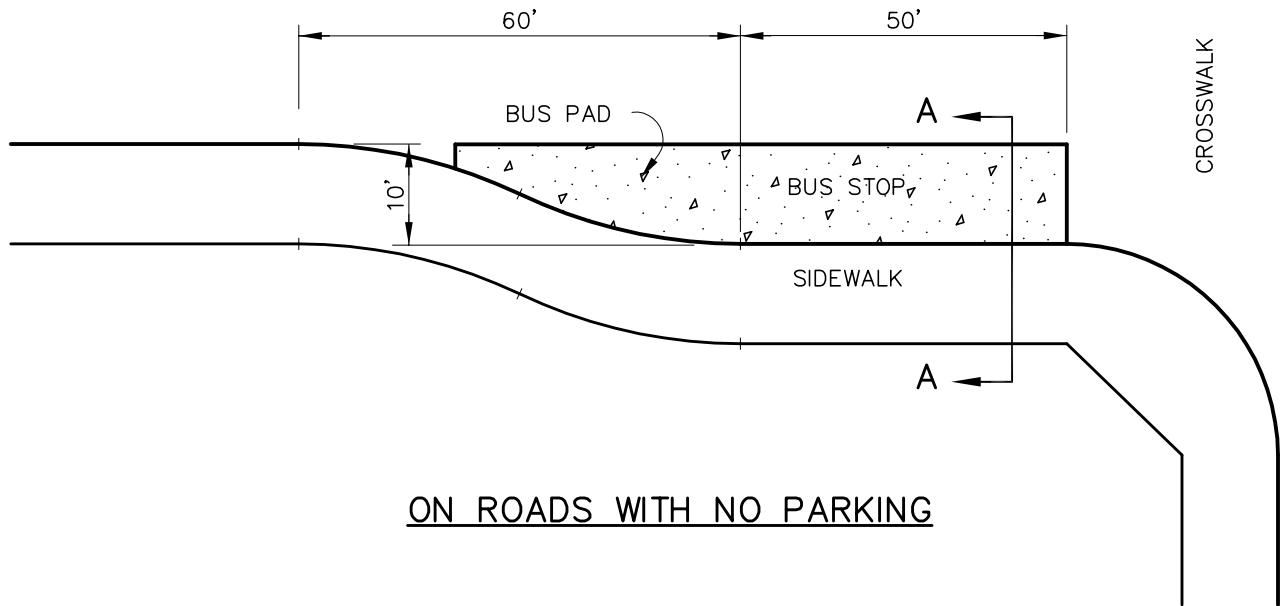

ON ROADS WITH NO PARKING

NOTES:

1. SEE SECTION A-A, MENDOT STD No. A14C
2. BUS BENCHES AND/OR SHELTER SHALL BE LOCATED BEHIND THE SIDEWALK OR IN SUCH A MANNER THAT A MINIMUM 5' CLEAR SIDEWALK IS PROVIDED.
3. DESIGN SHALL CONFORM TO THESE REQUIREMENTS, EXCEPT AS OTHERWISE APPROVED BY THE DOT DIRECTOR.



**BUS STOP –
INTERSECTION LOCATIONS**

MENDOT
STD. NO.
A14A



SCALE: NONE DESIGN: RCW DRAWN: LMM OCT. 2000
BUS STOP - MID BLOCK LOCATIONS

MENDOT STD. NO. **A14B**
PAGE: A-14

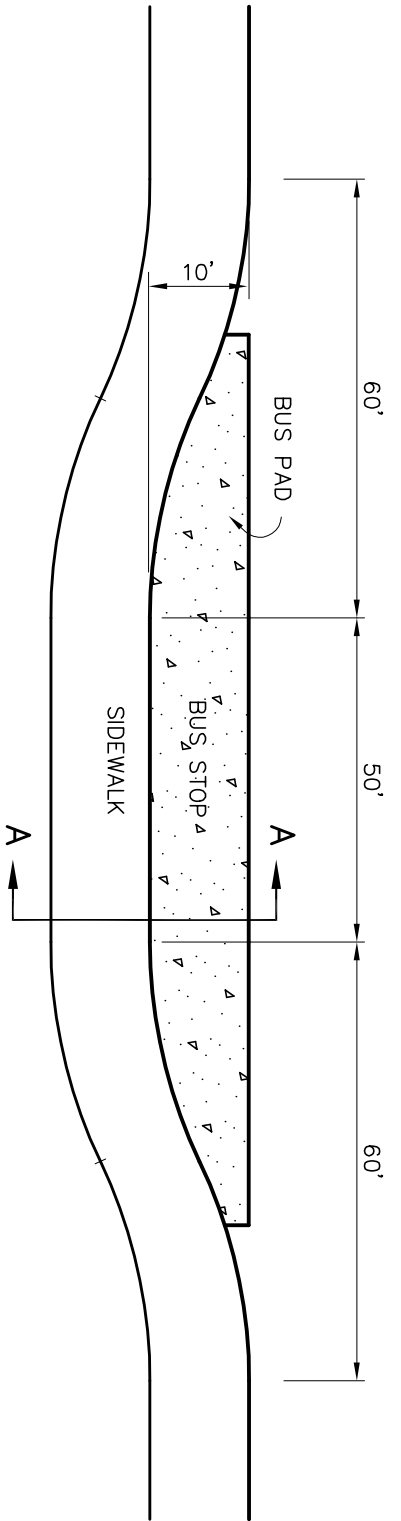
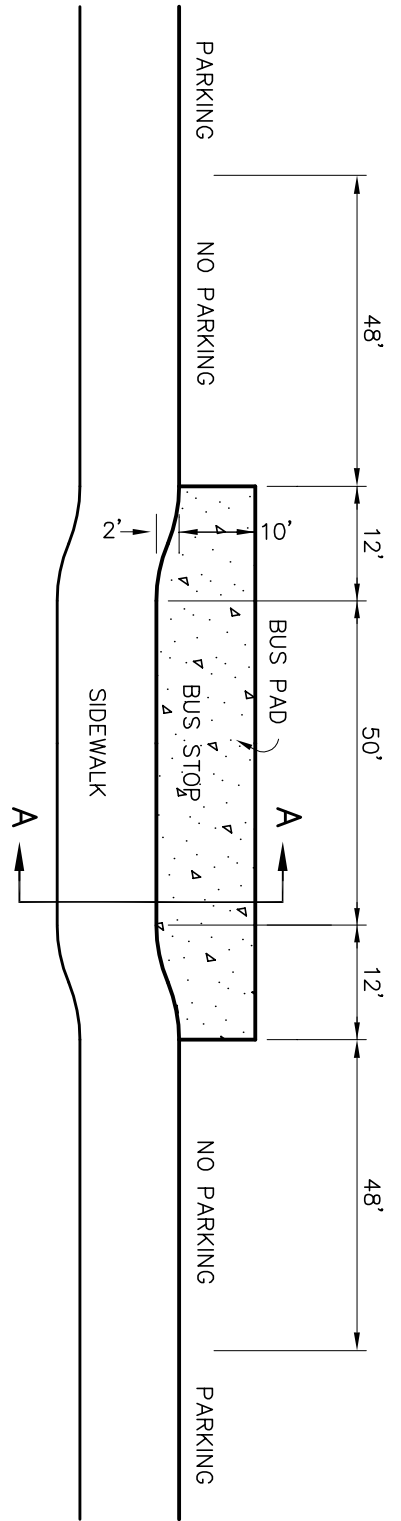

ON ROADS WITH NO PARKING

NOTES:

1. SEE SECTION A-A, MENDOT STD. No. A14C.
2. BUS BENCHES AND SHELTER SHALL BE LOCATED BEHIND THE SIDEWALK OR IN SUCH A MANNER THAT A MINIMUM 5' CLEAR SIDEWALK IS PROVIDED.
3. DESIGN SHALL CONFORM TO THESE REQUIREMENTS, EXCEPT AS OTHERWISE APPROVED BY THE DOT DIRECTOR.

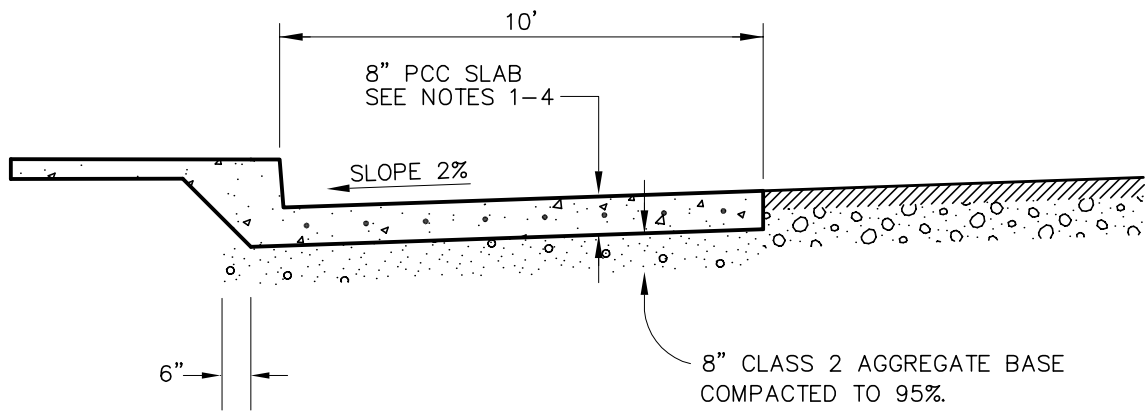

SECTION A-A

NOTES:

1. EXPANSION JOINTS & SCORE MARKS SHALL MATCH EXISTING CURB, GUTTER, & SIDEWALK.
2. USE CLASS "1" P.C.C. (6-SACK MIX) FOR BUS STOP SLAB.
3. CONSTRUCT SUBDRAINS WHEN REQUIRED BY DOT DIRECTOR.
4. REINFORCING STEEL REQUIRED IN CONC. #4 @ 12" O.C. EACH WAY, OR #5 @ 16" O.C. EACH WAY.
5. DESIGN SHALL CONFORM TO THESE REQUIREMENTS EXCEPT AS OTHERWISE APPROVED BY THE DOT DIRECTOR.



**BUS STOP –
SLAB DETAIL**

MENDOT
STD. NO.
A14C

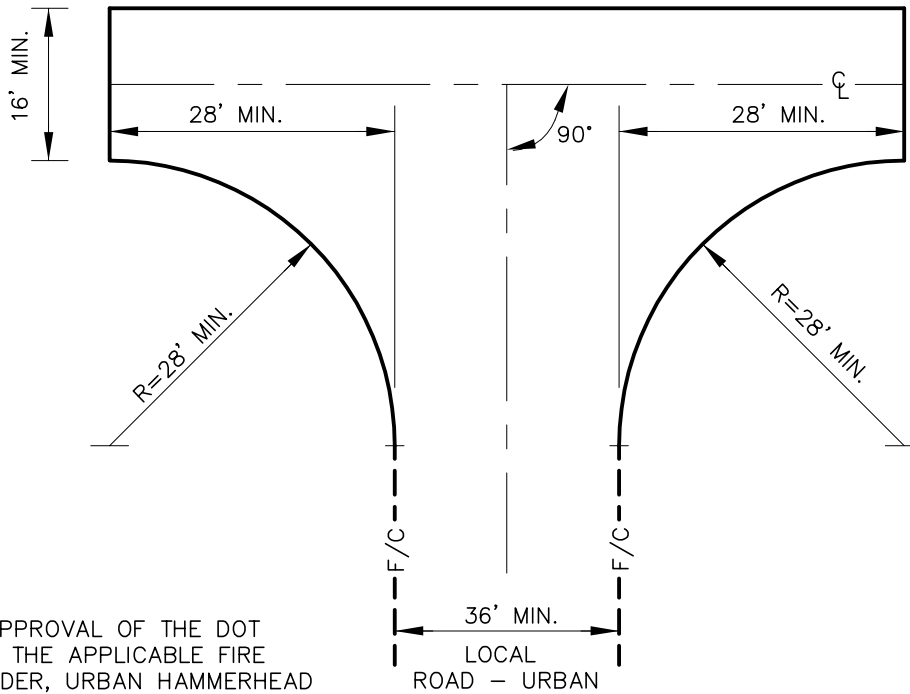
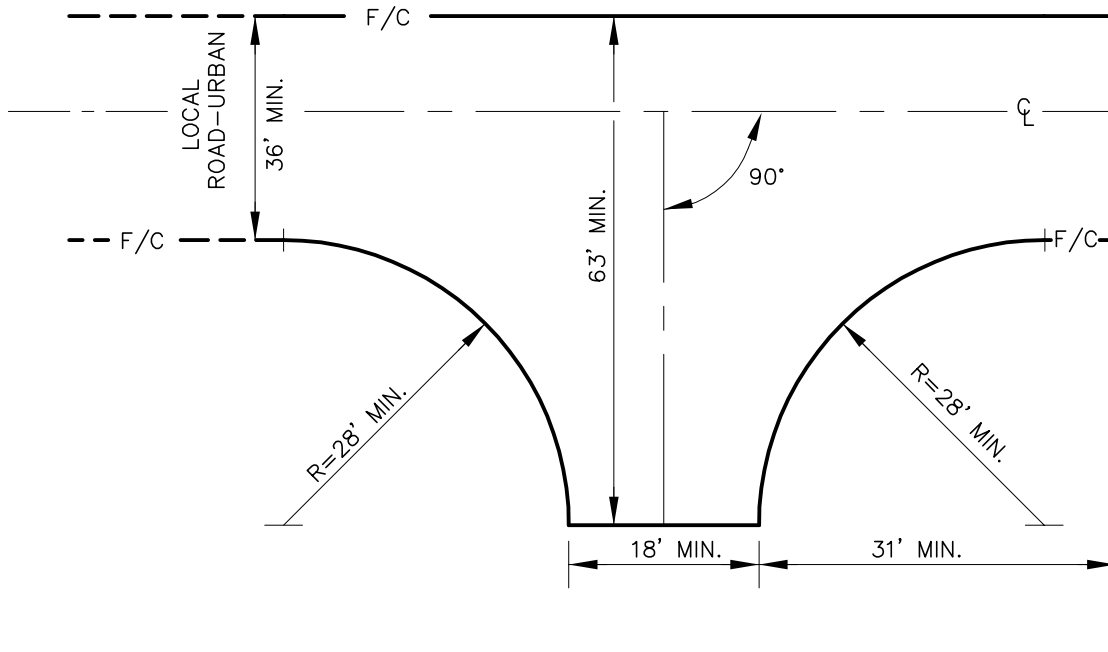

NOTE:

SUBJECT TO APPROVAL OF THE DOT DIRECTOR AND THE APPLICABLE FIRE SERVICE PROVIDER, URBAN HAMMERHEAD TURNAROUNDS MAY ONLY BE USED ON LOCAL ROADS AND SHALL ONLY BE USED WHERE TOPOGRAPHY PRECLUDES THE USE OF A CUL-DE-SAC DESIGN.



**HAMMERHEAD "T" TURNAROUND
URBAN**

MENDOT
STD. NO.
A15

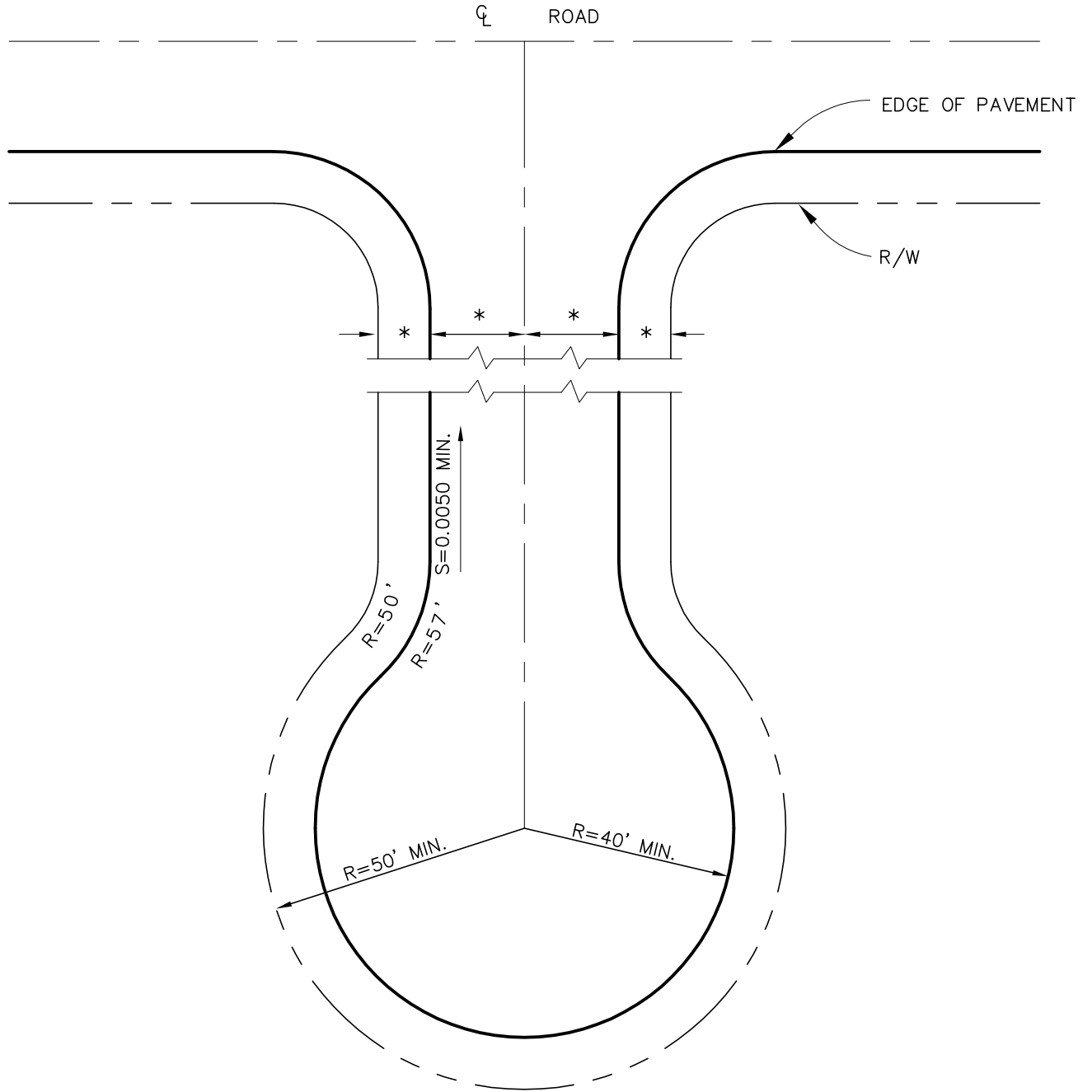

CROSS SLOPE IN BULB AREA
SHALL BE MIN. 2% AND MAX. 7%.

* VARIES. SEE ROAD CLASSIFICATIONS



RURAL CUL-DE-SAC

MENDOT
STD. NO.
A16

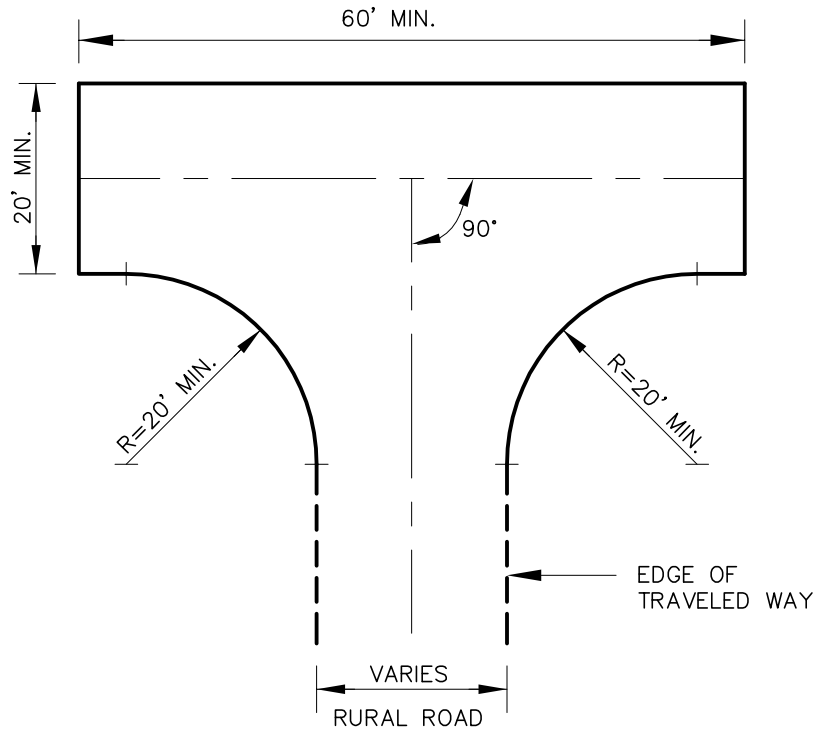
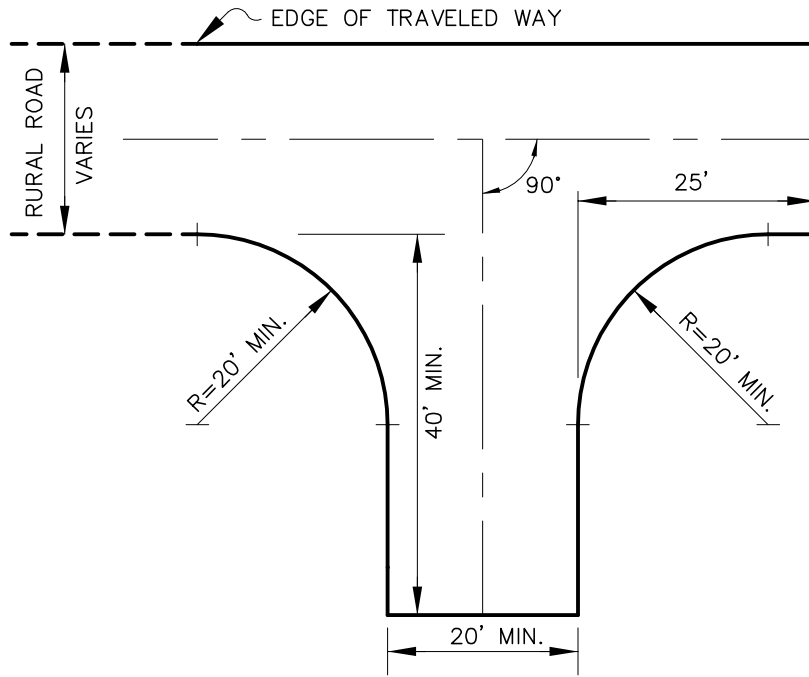

NOTE:

SUBJECT TO APPROVAL OF DOT DIRECTOR, AND THE APPLICABLE FIRE SERVICE PROVIDER, HAMMERHEAD TURN-AROUNDS SHALL ONLY BE USED WHERE TOPOGRAPHY PRECLUDES THE USE OF A CUL-DE-SAC DESIGN.



**HAMMERHEAD "T" TURNAROUND
RURAL**

MENDOT
STD. NO.
A17

TYPICAL SECTION "A"

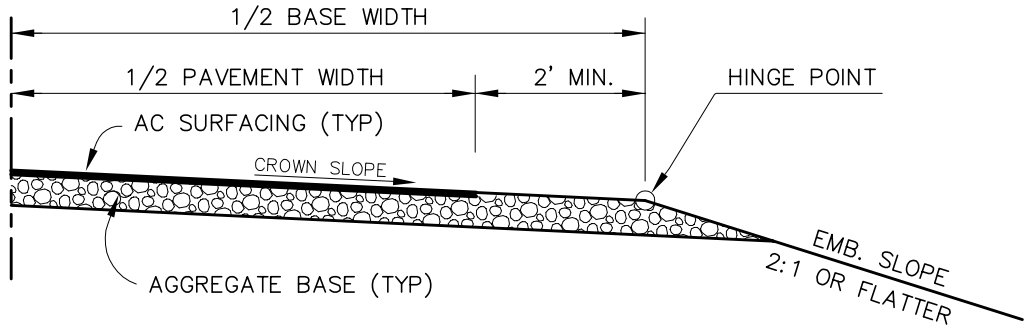

TYPICAL SECTION "B"

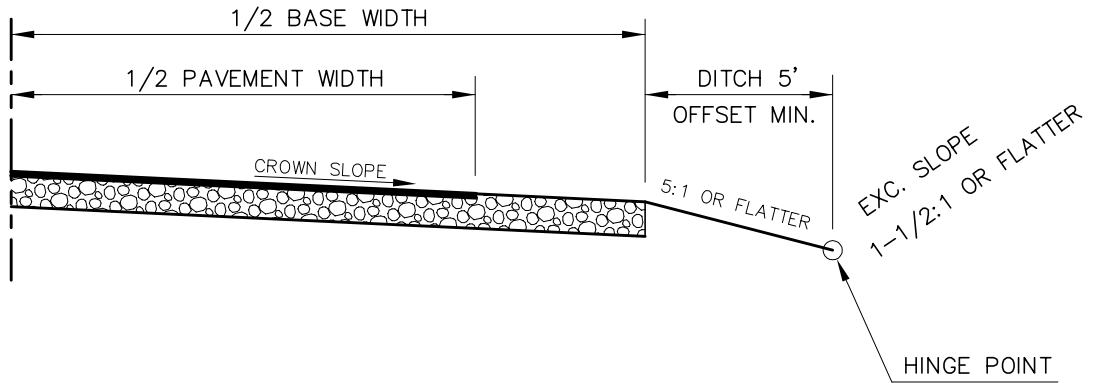

TYPICAL SECTION "C"

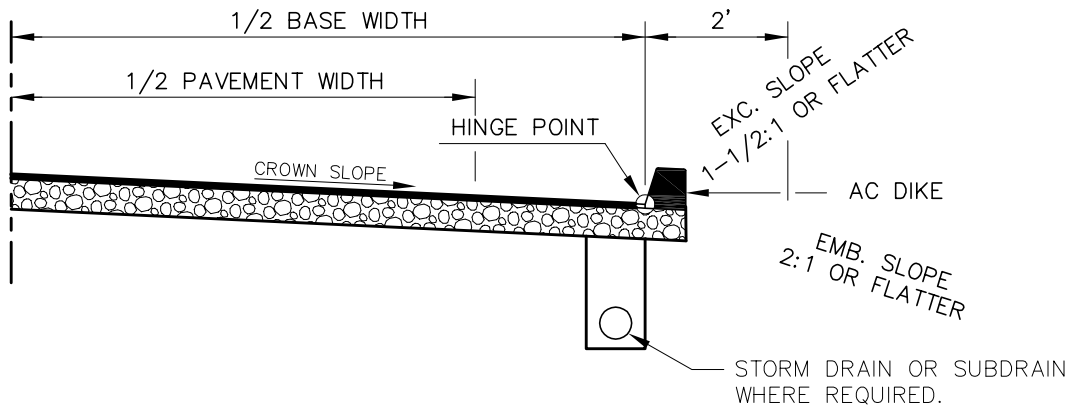

TYPICAL SECTION "D"

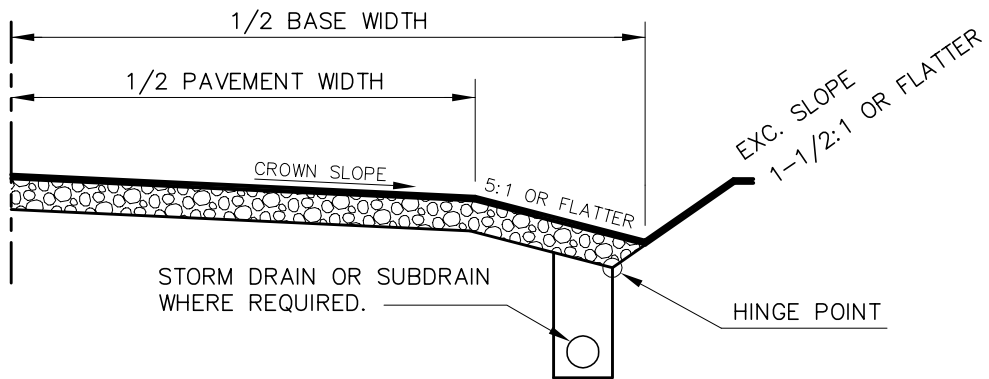

RURAL ROAD GRADING SECTIONS

MENDOT
STD. NO.
A18

GENERAL NOTES

1. ALL MATERIAL WORKMANSHIP AND CONSTRUCTION SHALL CONFORM TO THE COUNTY OF MENDOCINO STANDARD SPECIFICATIONS AND STANDARD PLANS AND THE STATE OF CALIFORNIA STANDARD PLANS AND SPECIFICATIONS, LATEST EDITION.
2. FOR WORK IN OR AFFECTING THE COUNTY ROAD RIGHT-OF-WAY, THE CONTRACTOR SHALL OBTAIN AN ENCROACHMENT PERMIT FROM THE COUNTY OF MENDOCINO (340 LAKE MENDOCINO DRIVE, UKIAH, CA 95482) BEFORE START OF WORK. CONTRACTOR SHALL COMPLY WITH ALL REQUIREMENTS OF THE PERMIT. FOR WORK IN OR AFFECTING THE STATE HIGHWAY RIGHT-OF-WAY, A CALTRANS ENCROACHMENT PERMIT IS REQUIRED.
3. CONTRACTOR SHALL OBTAIN REQUIRED PERMITS FROM ALL AGENCIES AND PAY ALL AGENCY FEES PRIOR TO COMMENCEMENT OF ANY WORK. CONTRACTOR SHALL CONFORM WITH ZONING CODE, BUILDING CODE, AND ALL OTHER REQUIREMENTS ADMINISTERED BY THE COUNTY OF MENDOCINO PLANNING AND BUILDING SERVICES DEPARTMENT.
4. CONTRACTOR SHALL GIVE THE COUNTY OF MENDOCINO DEPARTMENT OF TRANSPORTATION 48 HOURS NOTICE BEFORE STARTING WORK. CONTRACTOR SHALL ARRANGE A PRE-CONSTRUCTION MEETING. CALL (707) 463-4363 OR CONTACT AT 340 LAKE MENDOCINO DRIVE, UKIAH, CA 95482.
5. WORK HOURS ARE LIMITED TO MONDAY THROUGH FRIDAY, 7:00 A.M. TO 5:00 P.M. WHEN LANE CLOSURES ARE MADE FOR A WORK DAY ONLY, AT THE END OF EACH WORK DAY, ALL COMPONENTS OF THE TRAFFIC CONTROL SYSTEM, EXCEPT PORTABLE DELINEATORS PLACED ALONG OPEN TRENCHES OR EXCAVATION ADJACENT TO THE TRAVELED WAY, SHALL BE REMOVED FROM THE TRAVELED WAY AND SHOULDER. IF THE CONTRACTOR SO ELECTS, SAID COMPONENTS MAY BE STORED AT SELECTED CENTRAL LOCATIONS AS APPROVED BY THE DOT DIRECTOR, WITHIN THE LIMITS OF THE COUNTY RIGHT OF WAY. INSPECTION WILL BE AVAILABLE MONDAY THROUGH FRIDAY FROM 8:00 A.M. TO 4:30P.M. CONTRACTORS SHALL SCHEDULE INSPECTIONS 48 HOURS IN ADVANCE BY CALLING (707) 463-4363.
6. ANY DISCREPANCY DISCOVERED BY CONTRACTOR IN THESE PLANS OR ANY FIELD CONDITIONS DISCOVERED BY CONTRACTOR THAT MAY DELAY OR OBSTRUCT THE PROPER COMPLETION OF THE WORK PER THESE PLANS SHALL BE BROUGHT TO THE ATTENTION OF THE COUNTY DOT AND OWNER IMMEDIATELY UPON DISCOVERY. SAID NOTIFICATION SHALL BE IN WRITING.
7. GRADE BREAKS ON CURBS AND SIDEWALKS SHALL BE ROUNDED OFF IN FORMS AND SURFACE FINISHING.
8. ITEMS SPECIFIED ON THE STANDARD PLANS ARE APPROVED FOR USE BY THE COUNTY OF MENDOCINO. ALL SUBSTITUTES OR ALTERATIONS SHALL BE SUBMITTED TO THE COUNTY OF MENDOCINO FOR APPROVAL.
9. THE CONTRACTOR SHALL MAINTAIN A NEAT APPEARANCE TO THE WORK. IN ANY AREA VISIBLE TO THE PUBLIC, THE FOLLOWING SHALL APPLY:

 WHEN PRACTICABLE, BROKEN CONCRETE AND DEBRIS DEVELOPED DURING CLEARING AND GRUBBING SHALL BE DISPOSED OF CONCURRENTLY WITH ITS REMOVAL. IF STOCKPILING IS NECESSARY, THE MATERIAL SHALL BE REMOVED OR DISPOSED OF WEEKLY.

 THE CONTRACTOR SHALL FURNISH TRASH BINS FOR ALL DEBRIS FROM STRUCTURE CONSTRUCTION. ALL DEBRIS SHALL BE PLACED IN TRASH BINS DAILY. FORMS OR FALSEWORK THAT ARE TO BE REUSED SHALL BE STACKED NEATLY CONCURRENTLY WITH THEIR REMOVAL. FORMS AND FALSEWORK THAT ARE NOT TO BE REUSED SHALL BE DISPOSED OF CONCURRENTLY WITH THEIR REMOVAL.
10. CONTRACTOR SHALL COMPLY WITH ANY AND ALL MITIGATION MEASURES ADOPTED BY THE COUNTY OF MENDOCINO FOR THE PROJECT.
11. CONTRACTOR SHALL COMPLY WITH THE COUNTY OF MENDOCINO CODE 22.12 REGARDING THE DISCOVERY OF ARCHAEOLOGICAL SITES DURING THE PERFORMANCE OF WORK.
12. OWNER OR CONTRACTOR SHALL PROVIDE COMPACTION, GRADATION, SAND EQUIVALENT AND ALL OTHER TESTS AS REQUIRED BY THE COUNTY MENDOCINO.



**IMPROVEMENT PLAN
STANDARD NOTES – GENERAL**

MEN DOT
STD. NO.
A20A

SCALE: NONE | DESIGN: HND | DRAWN: HND | FEB. 2008

PAGE: A-20

NOTIFICATION FOR INSPECTIONS

APPROVAL OF ALL WORK SHALL BE NECESSARY AT THE COMPLETION OF EACH OF THE FOLLOWING STAGES OF WORK AND SUCH APPROVAL MUST BE OBTAINED BEFORE SUBSEQUENT STAGES OF WORK MAY BE COMMENCED. ADDITIONALLY, THE INSPECTOR SHALL BE NOTIFIED AT LEAST 48 HOURS IN ADVANCE OF ANY OF THE FOLLOWING STAGES OF WORK.

ANY CONSTRUCTION OR EXCAVATION REQUIRING INSPECTION THAT IS UNDERTAKEN WITHOUT INSPECTION IS SUBJECT TO RECONSTRUCTION AND REEXCAVATION AT THE CONTRACTOR'S EXPENSE.

INSPECTION MUST BE SCHEDULED FOR THE FOLLOWING WORK:

1. COMPACTION AND PREPARATION OF EMBANKMENTS, EXCAVATIONS, AND SUBGRADE.
2. CONSTRUCTION OF FORMS FOR ALL CONCRETE STRUCTURES, INCLUDING CURBS, GUTTERS, AND SIDEWALKS.
3. EXCAVATION FOR STORM DRAINS AND CULVERTS.
4. PLACING OF CONCRETE IN STRUCTURES, INCLUDING CURBS, GUTTERS AND SIDEWALKS.
5. PLACING OF STORM DRAINS AND CULVERT PIPES.
6. EXCAVATION AND BACKFILL FOR STRUCTURES AND PIPES AND PUBLIC UTILITIES. WATER AND SEWER FACILITIES MUST BE INSPECTED BY THE COMPANY/AGENCY WITH JURISDICTION.
7. CONSTRUCTION OF ROADSIDE DITCHES AND OTHER DRAINAGE WAYS.
8. PLACING AND COMPACTING OF BASE MATERIAL. IF MORE THAN ONE COURSE OR TYPE OF BASE OR SUBBASE IS TO BE USED, APPROVAL SHALL BE NECESSARY FOR EACH COURSE AND/OR TYPE.
9. PLACING OF PAVEMENT OR SURFACING. WITHIN 48 HOURS OF PAVING, ALL WATER VALVE BOXES, CLEANOUTS AND MANHOLE FRAMES AND COVERS SHALL BE BROUGHT TO GRADE AND INSPECTED.
10. STRIPING AND SIGNING LAYOUT AND PLACEMENT.
11. FINAL CLEAN-UP.



**IMPROVEMENT PLAN
STANDARD NOTES
NOTIFICATION FOR INSPECTIONS**

MENDOT
STD. NO.
A20B

GRADING STANDARD NOTES

1. AN ENCROACHMENT PERMIT MUST BE OBTAINED FROM THE COUNTY OF MENDOCINO DEPARTMENT OF TRANSPORTATION PRIOR TO ANY GRADING SHOWN ON THESE PLANS, CONTRACTOR SHALL ALSO COMPLY WITH ANY AND ALL GRADING PERMIT REQUIREMENTS ADMINISTERED BY THE COUNTY OF MENDOCINO PLANNING AND BUILDING SERVICES DEPARTMENT.
2. THE CONTRACTOR SHALL BE RESPONSIBLE FOR COORDINATING THE WORK WITH THE SOILS ENGINEER. ALL GRADING SHALL BE PERFORMED TO THE SATISFACTION OF THE SOILS ENGINEER AND SHALL BE IN CONFORMANCE WITH THE PROJECT SOILS REPORT.
3. ROAD SUBGRADE SHALL BE COMPACTED PER THE COUNTY STANDARD ROAD SPECIFICATIONS.
4. AS A MINIMUM, ALL GRADED AREAS AND EXPOSED SOIL WITHIN THIS PROJECT SHALL BE SEEDED FOR EROSION CONTROL BY THE CONTRACTOR. SEED AND MULCH WILL BE APPLIED BY OCTOBER 15TH TO ALL CUT AND FILL SLOPES WITHIN OR ADJACENT TO PROJECT ROADS. SEED AND FERTILIZER WILL BE APPLIED HYDRAULICALLY OR BY HAND AT THE RATES SPECIFIED BELOW. ON SLOPES, STRAW WILL BE APPLIED BY BLOWER OR BY HAND AND ANCHORED IN PLACE BY PUNCHING. ALL CRITICAL EARTHWORK OPERATIONS SHALL BE PERFORMED DURING THE DRY WEATHER SEASON, FROM APRIL 15TH TO OCTOBER 15TH OR AS OTHERWISE APPROVED BY THE DEPARTMENT OF TRANSPORTATION. THE CLEARING OF EXISTING VEGETATION SHALL BE CONFINED WITHIN THE LIMITS OF ACTUAL EARTHWORK. STAGING OF THE WORK SHALL BE REQUIRED TO ENSURE THAT THE AMOUNT OF LAND CLEARED AT ANY TIME IS LIMITED TO THE AREA THAT CAN BE DEVELOPED DURING THE CONSTRUCTION PERIOD. STORM WATER SHALL NOT BE ALLOWED TO FLOW DIRECTLY DOWN UNPROTECTED SLOPES. ENERGY DISSIPATING STRUCTURES AND EROSION CONTROL DEVICES SHALL BE PLACED AT ALL DRAINAGE OUTLETS WHICH DISCHARGE TO NATURAL CHANNELS AS SHOWN ON THESE PLANS. ALL SEDIMENT TRAPS SHALL BE MAINTAINED BY THE CONTRACTOR UNTIL SUCH TIME THAT THE COUNTY ACCEPTS MAINTENANCE RESPONSIBILITY.

<u>ITEM</u>	<u>POUNDS PER ACRE</u>
"BLANDO BROME"	30
ANNUAL RYE GRASS	20
FERTILIZER (16-20-0 & 15% SULPHUR)	500
STRAW MULCH	4000 OR 3500 LBS OF WOOD CELLULOSE

5. THE ABANDONMENT OR ALTERATION OF ANY AND ALL SEPTIC SYSTEMS AND WELLS SHALL COMPLY WITH THE COUNTY OF MENDOCINO HEALTH DEPARTMENT PERMIT REQUIREMENTS.
6. THE CONTRACTOR SHALL BE RESPONSIBLE TO PROVIDE DUST CONTROL MEASURES FOR THE ENTIRE CONSTRUCTION PERIOD OF THIS PROJECT TO THE SATISFACTION OF THE COUNTY AND AIR QUALITY MANAGEMENT DISTRICT AS APPLICABLE.
7. PROJECTS GREATER THAN OR EQUAL TO ONE (1) ACRE IN SIZE WILL REQUIRE A CONSTRUCTION GENERAL PERMIT AND STORM WATER POLLUTION PREVENTION PLAN (SWPPP) THROUGH THE APPROPRIATE REGIONAL WATER QUALITY CONTROL BOARD.
8. THE CONTRACTOR SHALL NOTIFY THE MENDOCINO COUNTY ENVIRONMENTAL HEALTH DEPARTMENT AT 234-6625 IMMEDIATELY IF HAZARDOUS WASTE OR MATERIAL IS ENCOUNTERED DURING EXCAVATION OF GRADING OPERATIONS.



**IMPROVEMENT PLAN
STANDARD NOTES – GRADING**

MEN DOT
STD. NO.
A20C

SCALE: NONE | DESIGN: HND | DRAWN: HND | FEB. 2008

PAGE: A-22

UNDERGROUND CONSTRUCTION STANDARD NOTES

1. NO GUARANTEE IS INTENDED THAT UNDERGROUND OBSTRUCTIONS, NOT SHOWN ON THESE PLANS, MAY BE ENCOUNTERED. THOSE SHOWN ARE BASED ON THE BEST INFORMATION AVAILABLE AND THE CONTRACTOR IS CAUTIONED THAT THE OWNER, THE ENGINEER, AND THE COUNTY OF MENDOCINO ASSUME NO RESPONSIBILITY FOR ANY OBSTRUCTIONS EITHER SHOWN OR NOT SHOWN ON THESE PLANS. THE CONTRACTOR SHALL COOPERATE WITH ALL UTILITY COMPANIES WORKING WITHIN THE LIMITS OF THIS PROJECT.
2. CONTRACTOR SHALL NOT BEGIN EXCAVATION UNTIL ALL EXISTING UTILITIES HAVE BEEN MARKED IN THE FIELD BY THE APPLICABLE ENTITY RESPONSIBLE FOR THAT PARTICULAR UTILITY. THE CONTRACTOR SHALL NOTIFY EACH APPLICABLE ENTITY AT LEAST 24 HOURS BEFORE STARTING WORK.
3. UNDERGROUND SERVICE ALERT: CALL TOLL FREE (800) 227-2600 OR 811 AT LEAST 48 HOURS PRIOR TO EXCAVATION.
4. CONTRACTOR SHALL UNCOVER EXISTING BURIED UTILITIES WITH UTILITY OWNER TO VERIFY LOCATIONS AND ELEVATIONS OF UTILITIES. BURIED UTILITIES INCLUDE BUT ARE NOT LIMITED TO WATER MAINS AND LATERALS, SEWER MAINS, STORM DRAINS, GAS MAINS AND LATERALS, ELECTRICAL DISTRIBUTION LINES AND TELEPHONE LINES. ALL UTILITIES CONFLICTING WITH THE PROPOSED CONSTRUCTION SHALL BE RELOCATED PRIOR TO THE START OF CONSTRUCTION.
5. THE CONTRACTOR SHALL VERIFY EXISTING INVERTS PRIOR TO THE COMMENCEMENT OF ANY CONSTRUCTION. THE CIVIL ENGINEER IN RESPONSIBLE CHARGE OF THE WORK MAY ADJUST THE GRADE OF NEW STORM DRAIN CONSTRUCTION ACCORDINGLY WITH CONCURRENCE FROM THE COUNTY DEPARTMENT OF TRANSPORTATION.
6. DISTANCES AND INVERTS ARE TO AND AT THE CENTER OF THE MANHOLES, CLEANOUTS, DROP INLETS, CATCH BASINS, AND YARD DRAINS OR AS MARKED ON THE DRAWINGS.
7. ALL UNDERGROUND IMPROVEMENTS SHALL BE INSTALLED AND APPROVED PRIOR TO PAVING.
8. THE CONTRACTOR SHALL STAMP THE LETTER "S" ON THE FACE OF CURB DIRECTLY ABOVE THE SEWER LATERAL, AND THE LETTER "W" ON THE FACE OF CURB DIRECTLY ABOVE WATER SERVICES, AND "B" ON FACE OF CURB DIRECTLY ABOVE A BLOW OFF OR AIR RELIEF VALVE. AT A DRIVEWAY THE STAMP SHALL BE PLACED AT THE BACK OF RAMP. THE LETTERS SHALL BE 4" HIGH AND COMPLETELY LEGIBLE.
9. SURFACE MOUNTED TRANSFORMERS SHALL NOT BE USED UNLESS LOCATION OF SUCH UTILITIES ARE SHOWN ON THE PLANS AND APPROVED BY THE COUNTY.



**IMPROVEMENT PLAN
STANDARD NOTES
UNDERGROUND CONSTRUCTION**

MENDOT
STD. NO.
A20D

DRAINAGE STANDARD NOTES

1. STORM DRAIN CONDUITS SHALL CONFORM TO CALTRANS SPECIFICATIONS AND SHALL BE R.C.P. PIPE, CORRUGATED METAL PIPE OR HDPE PLASTIC PIPE WITH SMOOTH INTERIOR WALL. CORRUGATED METAL PIPE SHALL NOT BE USED IN THE ROAD RIGHT-OF-WAY, EXCEPT FOR DRIVEWAY CULVERTS, CROSS CULVERTS, AND CREEK OUTLETS. MINIMUM COVER OVER PIPE TO BE 30", EXCEPT WHERE SLURRY CEMENT BACKFILL IS PROVIDED PER MENDOT STD. A60C. THE MAXIMUM ALLOWABLE COVER SHALL BE LIMITED TO 11 FEET FOR ALL SIZES.
2. ALL STORM DRAIN MANHOLES SHALL BE A MINIMUM OF 48" IN DIAMETER. UNLESS OTHERWISE NOTED, MANHOLE FRAME AND COVER SHALL HAVE 24" CLEAR OPENING, AND BE HEAVY DUTY NON-ROCKING. RAISED LETTERS ON TOP OF THE COVER SHALL READ "STORM DRAIN". PIPES SHALL NOT PROTRUDE INSIDE THE MANHOLE. PIPE ENDS SHALL BE ROUNDED.
3. REINFORCED CONCRETE PIPE AND CAST-IN-PLACE STORM DRAIN PIPE SHALL BE PLACED AND BACKFILLED IN ACCORDANCE WITH STANDARD DRAWINGS A60A, A60B, AND A60C. STORM DRAIN WITHIN COUNTY MAINTAINED ROADS SHALL BE MINIMUM 18 INCH DIAMETER, WITH FOLLOWING EXCEPTIONS:
 - A. LATERALS SERVING INDIVIDUAL PROPERTIES MAY BE 12 INCH DIAMETER
 - B. DRIVEWAY CULVERTS MAY BE A MINIMUM OF 12 INCH DIAMETER.



**IMPROVEMENT PLAN
STANDARD NOTES – DRAINAGE**

MENDOT
STD. NO.
A20E

SIGNING, STRIPING AND PAVEMENT MARKINGS STANDARD NOTES

1. CONTRACTOR SHALL NOTIFY THE COUNTY DEPARTMENT OF TRANSPORTATION (DOT) OF CONTRACTOR'S INTENT TO PLACE ANY PAVEMENT MARKER, TRAFFIC STRIPE, PAVEMENT MARKING, AND PAVEMENT LEGEND LAYOUT LINES 10 WORKING DAYS BEFORE THE MARKER AND STRIPES WORK IS TO BE PERFORMED. ALL LABOR, EQUIPMENT AND MATERIALS SHALL BE PROVIDED BY THE CONTRACTOR.
2. ALL LAYOUT WORK IS TO BE PERFORMED BY THE CONTRACTOR AND SHALL BE FIELD APPROVED BY A COUNTY INSPECTOR BEFORE THE ACTUAL WORK BEGINS.
3. PAVEMENT MARKERS AND TRAFFIC STRIPE DETAIL REFERENCE NUMBERS ARE SHOWN ON CALTRANS STANDARD PLANS A20-A, A20-B, A20-C AND A20-D.
4. ROADSIDE SIGNS: ROADSIDE SIGNS SHALL BE AS SHOWN ON THE PLANS, IN ACCORDANCE WITH THE PROVISIONS OF SECTION 56, "SIGNS", OF THE STANDARD SPECIFICATIONS, AND AS DIRECTED BY THE COUNTY DEPARTMENT OF TRANSPORTATION.
5. SIGN PANELS SHALL CONFORM TO THE CURRENT CALTRANS SIGN PANEL SPECIFICATIONS. MINIMUM GRADE OF SIGN SHEETING MATERIAL SHALL BE TYPE 2, SUPER ENGINEERING GRADE, PER MOST CURRENT ASTM SPECIFICATION, OR HIGHER GRADE AS REQUIRED BY THE DOT DIRECTOR. SIGNS USED FOR SCHOOL AREA TRAFFIC CONTROL SHALL BE RETROFLECTIVE OR ILLUMINATED, AS SHOWN ON PLANS.
6. LOCATIONS OF ALL SIGNS SHALL BE AS SHOWN ON THE PLANS AND AS DIRECTED BY THE COUNTY.
7. SIGN PANELS SHALL BE MOUNTED ON METAL OR WOOD POSTS AS SHOWN ON THE PLANS. POST MATERIALS AND INSTALLATION SHALL BE PER THE CALTRANS STANDARD PLANS AND SPECIFICATIONS. METAL POSTS SHALL BE WIDE-FLANGE METAL POSTS PER CALTRANS STANDARD SPECIFICATIONS. ALL FASTENERS AND ATTACHMENT HARDWARE SHALL BE GALVANIZED.
8. MARKERS AND DELINEATORS: MARKERS AND DELINEATORS SHALL BE AS SHOWN ON THE PLANS AND IN ACCORDANCE WITH THE PROVISIONS OF SECTION 82, "MARKERS AND DELINEATORS" OF THE STANDARD SPECIFICATIONS AND THESE SPECIAL PROVISIONS, AND AS DIRECTED BY THE COUNTY DEPARTMENT OF TRANSPORTATION DIRECTOR.
9. LOCATION OF ALL MARKERS AND DELINEATORS SHALL BE AS SHOWN ON THE PLANS AND AS DIRECTED BY THE COUNTY DEPARTMENT OF TRANSPORTATION DIRECTOR.
10. TRAFFIC STRIPES AND PAVEMENT MARKINGS: TRAFFIC STRIPES AND PAVEMENT MARKINGS SHALL BE AS SHOWN ON THE PLANS, IN ACCORDANCE WITH THE PROVISIONS OF SECTION 84, "TRAFFIC STRIPES AND PAVEMENT MARKINGS" OF THE STANDARD SPECIFICATIONS AND AS DIRECTED BY THE COUNTY DEPARTMENT OF TRANSPORTATION DIRECTOR.



**IMPROVEMENT PLAN
STANDARD NOTES
SIGNING, STRIPING & MARKINGS**

MENDOT
STD. NO.
A20F

SIGNING, STRIPING AND PAVEMENT MARKINGS STANDARD NOTES (CONTINUED)

11. ALL STRIPING PAVEMENT MARKINGS, INCLUDING STOPLINES, AND ALL CHANNELIZING LINES SHALL BE THERMOPLASTIC UNLESS OTHERWISE SHOWN OR NOTED ON THE PLANS.
12. THERMOPLASTIC TRAFFIC STRIPES AND PAVEMENT MARKINGS: THERMOPLASTIC TRAFFIC STRIPES AND PAVEMENT MARKINGS SHALL CONFORM TO THE PROVISIONS OF SECTION 84-2, "THERMOPLASTIC TRAFFIC STRIPES AND PAVEMENT MARKINGS" OF THE STANDARD SPECIFICATIONS.
13. THERMOPLASTIC MATERIAL SHALL BE APPLIED AT A MINIMUM THICKNESS OF 0.125 INCH.
14. PAVEMENT MARKERS: PAVEMENT MARKERS SHALL BE IN ACCORDANCE WITH THE PROVISIONS OF SECTION 85, "PAVEMENT MARKERS" OF THE STANDARD SPECIFICATIONS.
15. PAINTED/THERMOPLASTIC STRIPES AND PAVEMENT MARKINGS: EXISTING PAINTED/THERMOPLASTIC TRAFFIC STRIPES AND PAVEMENT MARKINGS WHICH CONFLICT WITH THE NEW TRAFFIC STRIPING AND PAVEMENT MARKING PLANS SHALL BE REMOVED BY THE CONTRACTOR IN ACCORDANCE WITH SECTION 15-2, REMOVAL METHODS, OF THE CALTRANS STANDARD SPECIFICATIONS.
16. RAISED PAVEMENT MARKER REMOVAL: EXISTING RAISED PAVEMENT MARKERS WHICH CONFLICT WITH THE NEW TRAFFIC STRIPING AND PAVEMENT MARKING PLAN SHALL BE REMOVED BY THE CONTRACTOR IN ACCORDANCE WITH SECTION 15-2, REMOVAL METHODS, OF THE CALTRANS STANDARD SPECIFICATIONS.



**IMPROVEMENT PLAN
STANDARD NOTES – SIGNING,
STRIPING & MARKINGS (CONTINUED)**

MENDOT
STD. NO.
A20G

SCALE: NONE | DESIGN: RCW | DRAWN: LMM | OCT. 2000

PAGE: A-26

LIGHTING NOTES:

1. ALL WIRING METHODS AND EQUIPMENT CONSTRUCTION SHALL CONFORM TO THE CURRENT NATIONAL ELECTRICAL CODE.
2. ALL WIRING SHALL BE IN APPROVED CONDUIT. ALL CONDUIT SHALL BE A MINIMUM OF 2" DIAMETER, SCHEDULE 40 P.V.C. (POLYVINYL CHLORIDE), EXCEPT FROM EACH STREET LIGHT TO THE ADJACENT PULL BOX WHICH MAY BE 1" DIAMETER PVC OR METAL, AND SHALL HAVE THE FOLLOWING COVER FROM TOP OF CONDUIT.
 - A. WITHIN SIDEWALK OR PARKWAY AREAS: 18" MIN.
 - B. WITHIN ROADWAY AREAS: 30" MIN.
3. ALL METAL CONDUIT AND OTHER METAL PARTS SHALL BE CONTINUOUSLY BONDED AND GROUNDED.
4. ALL BENDS AND/OR OFFSETS SHALL BE MADE WITH FACTORY SECTIONS.
5. UNLESS OTHERWISE APPROVED BY THE DOT DIRECTOR, A NO. 5 PULL BOX (STATE STD. ES-8) SHALL BE USED AT ALL STREET LIGHT STANDARDS.
6. ALL PULL BOXES SHALL BE PER CALTRANS STD. No. ES-8.
7. WHEN PULL BOXES ARE SUBJECT TO VEHICULAR TRAFFIC, THEY SHALL BE SET ON CONCRETE FOOTINGS AND CAST IRON TRAFFIC COVERS SHALL BE INSTALLED.
8. ALL SPLICES SHALL BE MADE WITH APPROVED SOLDERLESS WATERPROOF CONNECTORS OF THE PROPER SIZE PER NEC 300-15. (EXAMPLE: WIRENUT OR SPLIT BOLT PLUS TAPE PLUS COATING.) ALL SPLICES SHALL BE LOCATED IN AN APPROVED BOX.
9. ALL EMPTY CONDUITS SHALL HAVE A 1/4" NYLON PULL ROPE PROVIDED INSIDE.
10. ALL CONDUITS SHALL BE SEALED WITH AN APPROVED DUCT SEAL. CONDUITS STUBBED FOR FUTURE EXTENSION SHALL BE CAPPED.
11. ALL STREET LIGHTING PROJECTS ARE SUBJECT TO APPROVAL BY THE DOT DIRECTOR.
12. ALL PULL BOX COVERS SHALL BE SECURED WITH BRASS HOLD DOWN BOLTS AND INSCRIBED, "STREET LIGHTING".
13. ALL STREET LIGHTS EQUIPPED WITH A PHOTOCELL CONTROL SHALL HAVE THE PHOTOCELL ORIENTED TO THE NORTH.
14. ALL WIRE SHALL BE THHN A.W.G. THE MINIMUM SIZE SHALL BE #8.



**IMPROVEMENT PLAN
STANDARD NOTES – LIGHTING**

MENDOT
STD. NO.
A20H

SCALE: NONE | DESIGN: RCW | DRAWN: LMM | OCT. 2000

PAGE: A-27

PRESERVATION OF SURVEY MONUMENTS:

1. CONTRACTOR IS RESPONSIBLE FOR PRESERVATION AND/OR PERPETUATION OF ALL EXISTING MONUMENTS WHICH CONTROL SUBDIVISIONS, TRACTS, BOUNDARIES, STREETS, HIGHWAYS, OR OTHER RIGHTS-OF-WAY, EASEMENTS, OR PROVIDE SURVEY CONTROL WHICH WILL BE DISTURBED OR REMOVED DUE TO CONTRACTOR'S WORK. CONTRACTOR SHALL PROVIDE A MINIMUM OF 10 WORKING DAYS NOTICE TO CIVIL ENGINEER OR SURVEYOR IN RESPONSIBLE CHARGE OF THE WORK PRIOR TO DISTURBANCE OR REMOVAL OF EXISTING MONUMENTS. CIVIL ENGINEER OR SURVEYOR IN RESPONSIBLE CHARGE OF THE WORK SHALL COORDINATE WITH CONTRACTOR TO RESET MONUMENTS OR PROVIDE PERMANENT WITNESS MONUMENTS AND FILE THE REQUIRED DOCUMENTATION WITH THE COUNTY SURVEYOR PURSUANT TO BUSINESS AND PROFESSIONS CODE SECTION 8771.

2. CONTRACTOR IS RESPONSIBLE FOR ALL COSTS TO RESET ANY RECORD SURVEY MONUMENTS DAMAGED BY CONTRACTOR'S FORCES – PERSONNEL OR SUB-CONTRACTORS.



**IMPROVEMENT PLAN STANDARD
NOTES – PRESERVATION OF
SURVEY MONUMENTS**

MENDOT
STD. NO.
A20I

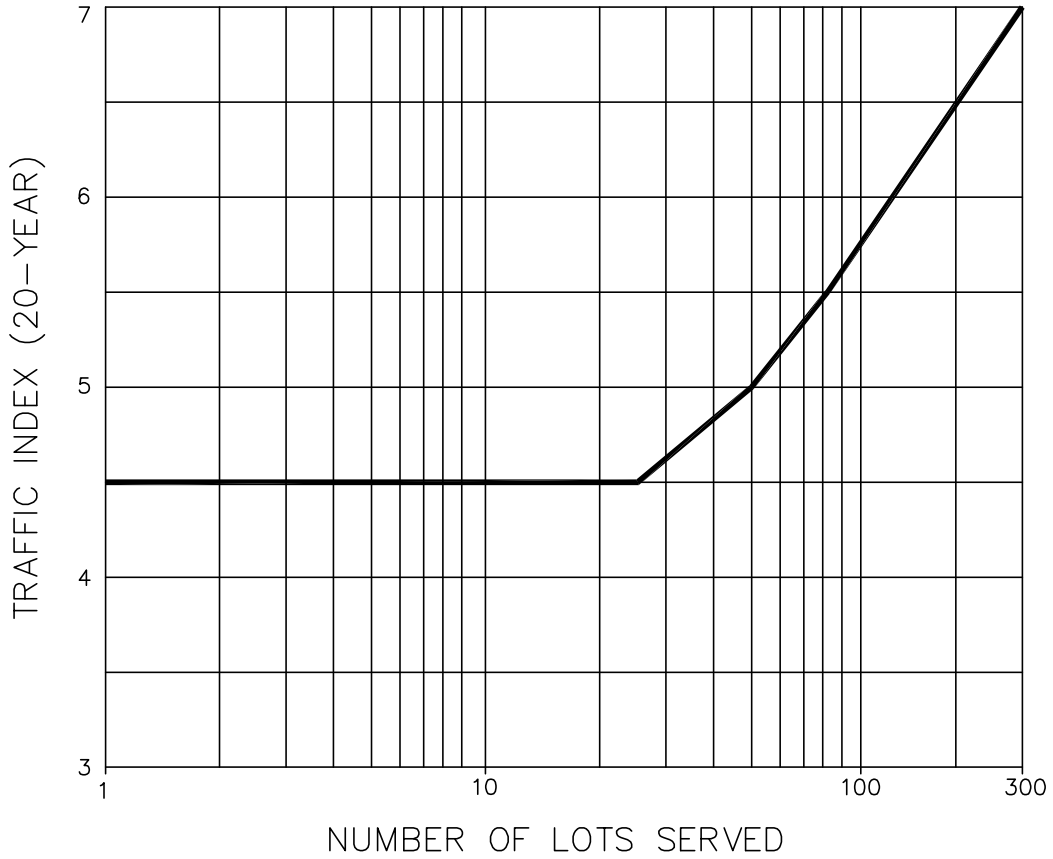

T.I. = 2.472 (LOTS)^{0.1825}

MIN. T.I. = 4.5

NOTES:

1. FOR USE WITH RESIDENTIAL ROADS THAT SERVE OR MAY SERVE 300 LOTS OR LESS.
2. CHART IS BASED ON A 20 YEAR DESIGN LIFE.
3. THE NUMBER OF LOTS SERVED SHALL INCLUDE ALL LOTS WHOSE RESIDENTS WOULD USE THE ROAD FOR ACCESS. LOTS ON THE ROAD UNDER DESIGN OR ON CONNECTING ROADS SHALL BE INCLUDED IN THE TOTAL.



**TRAFFIC INDEX (TI) CHART
FOR FLEXIBLE PAVEMENTS –
RESIDENTIAL ROADS**

MENDOT
STD. NO.
A21

STRUCTURAL DESIGN CHART FOR FLEXIBLE PAVEMENTS

EQUATION:
 $G.E. = 0.0032 (T.I.)(100-R)$

G.E. = GRAVEL EQUIVALENT
 T.I. = TRAFFIC INDEX
 R = RESISTANCE VALUE

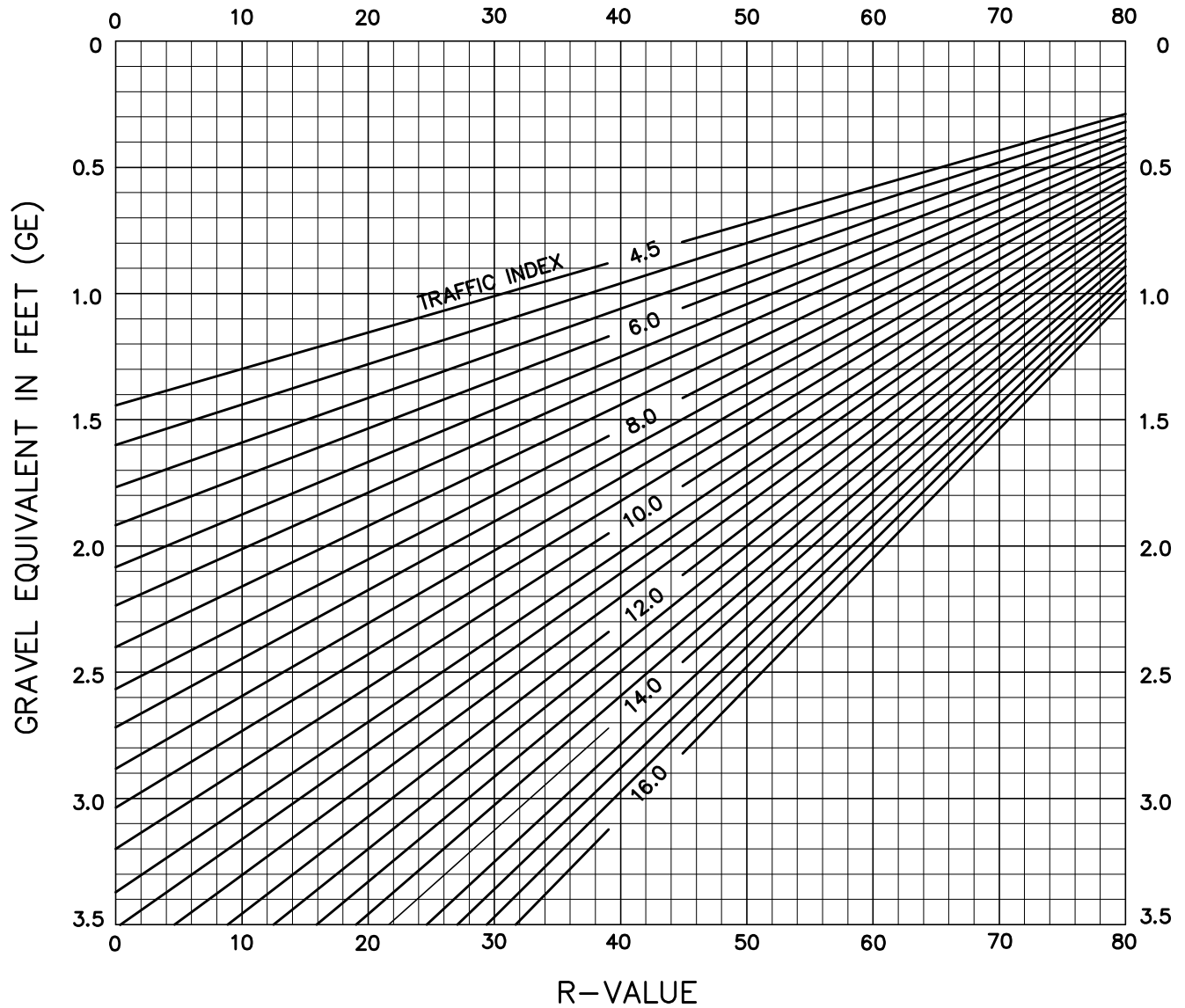

GRAVEL EQUIVALENTS (GE) CHART FOR FLEXIBLE PAVEMENTS

MENDOT
 STD. NO.
A22

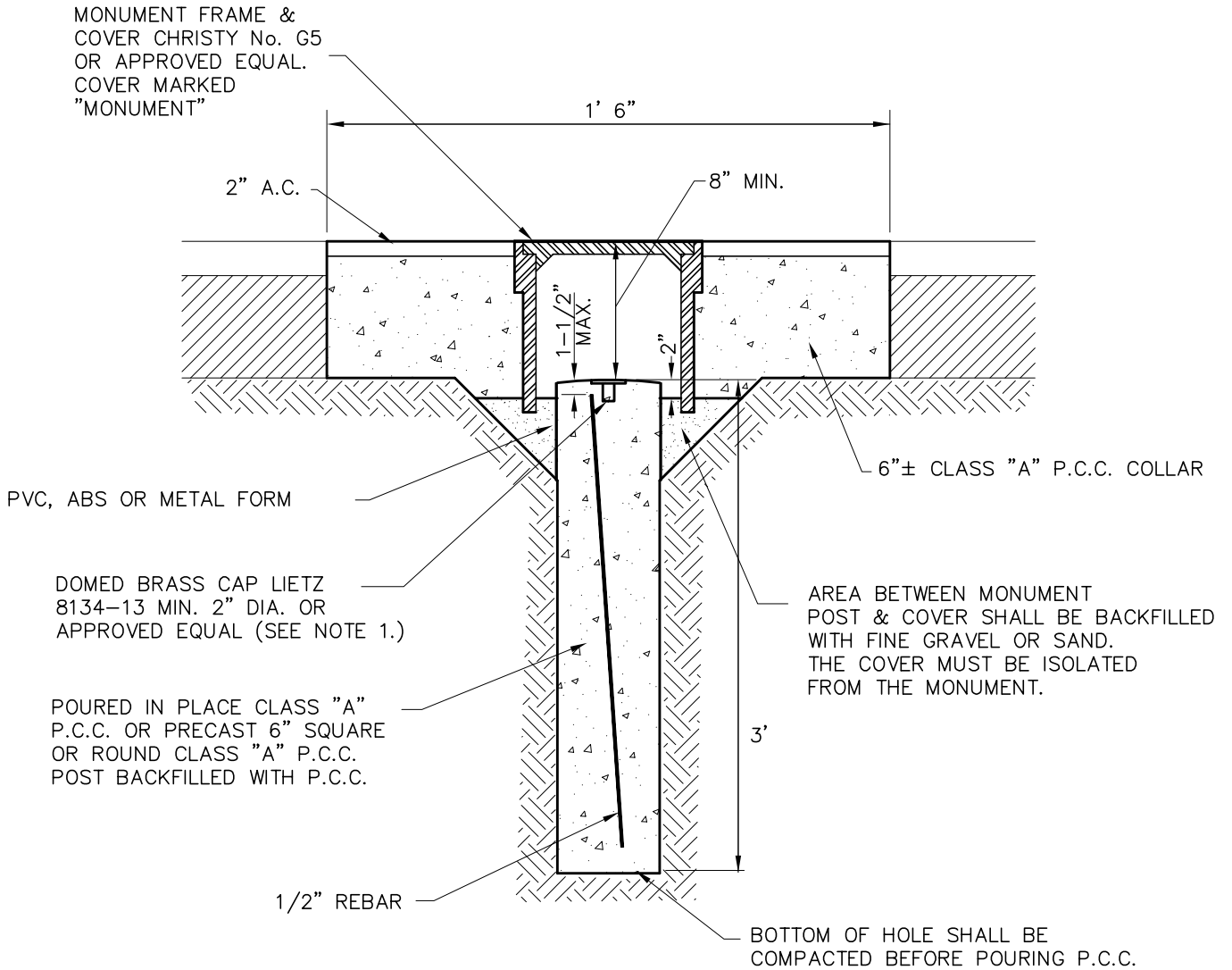

NOTES:

1. SURVEYOR OR ENGINEER SETTING THE MONUMENT SHALL INDICATE EXACT POINT BY MAKING A CROSS ON THE CAP AND SHALL STAMP YEAR SET AND HIS/HER LICENSE TYPE AND NUMBER.
2. THE DEPTH OF THE MONUMENT POST SHALL BE LENGTHENED OR SHORTENED AS DICTATED BY THE GROUND CONDITIONS OR AS APPROVED BY THE DOT DIRECTOR. IN SOFT GROUND OR FILL AREAS THE MONUMENT POST SHALL BE LENGTHENED TO BED IT ON A STABLE BASE.



SURVEY MONUMENT – ROAD

MENDOT
STD. NO.
A30



BARRICADE - ROAD

MENDOT
STD. NO.
A31

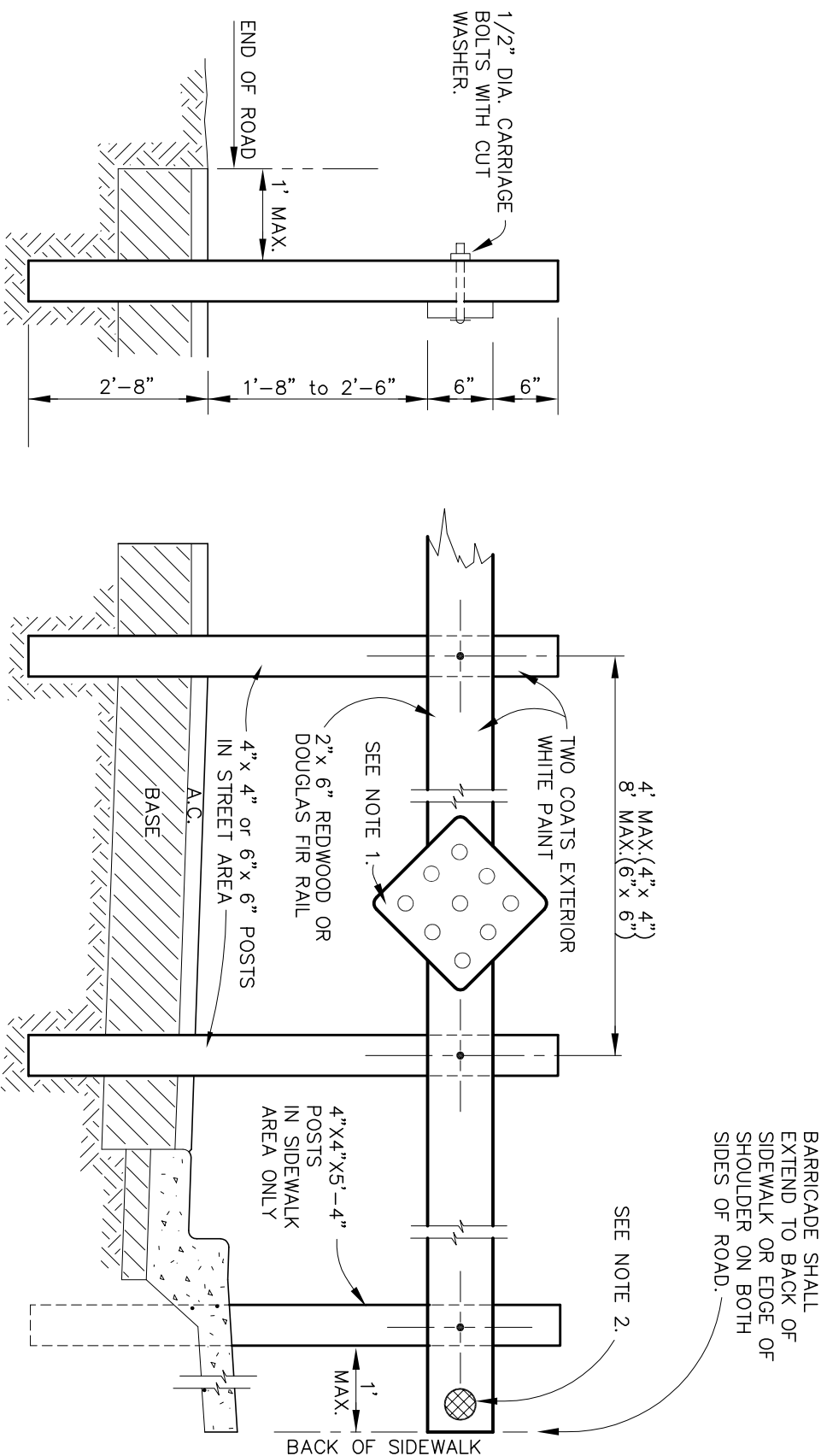

NOTES:

1. INSTALL 18" X 18" ALUMINUM TYPE N-5 REFLECTOR, NO MORE THAN 8' O.C., MINIMUM 3
2. SIDEWALKS ONLY - INSTALL 4" YELLOW REFLECTORS AT 3' O.C.
3. POSTS SHALL BE CLEAR REDWOOD OR PRESSURE TREATED FIR APPROVED FOR IN GROUND USE UNDER UBC.
4. ALL HARDWARE SHALL BE HOT-DIPPED GALVANIZED.



BARRICADE - SIDEWALK

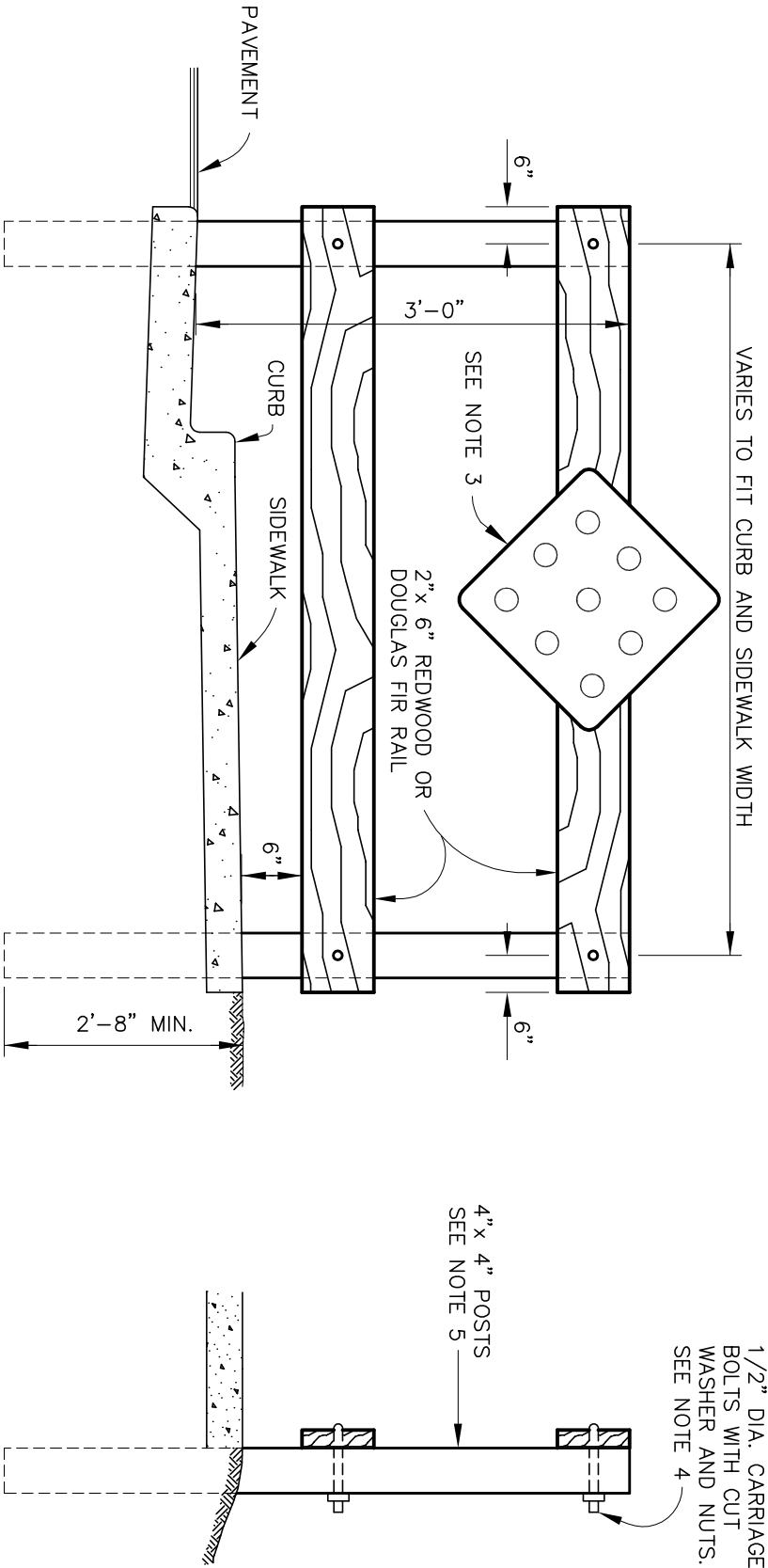

NOTES:

1. SIDEWALK BARRICADES TO BE ERRECTED AT ANY LOCATION WHERE SATISFACTORY PROVISION CAN NOT MADE FOR PEDESTRIANS TO CONTINUE BEYOND THE TERMINUS OF A SIDEWALK.
2. ALL EXPOSED SURFACES TO BE PAINTED WITH TWO (2) COATS OF WHITE PAINT.
3. INSTALL 18" X 18" ALUMINUM TYPE N-5 REFLECTOR, NO MORE THAN 8' O.C., MINIMUM 3
4. ALL HARDWARE SHALL BE HOT-DIPPED GALVANIZED.
5. POSTS SHALL BE CLEAR REDWOOD OR PRESSURE-TREATED FIR APPROVED FOR IN-GROUND USE UNDER UBC.

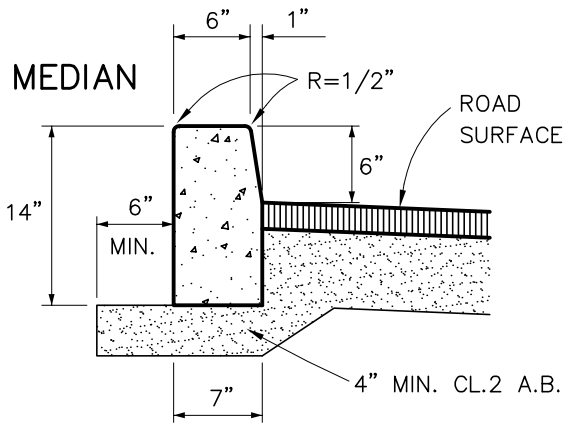

**STANDARD
VERTICAL CURB**

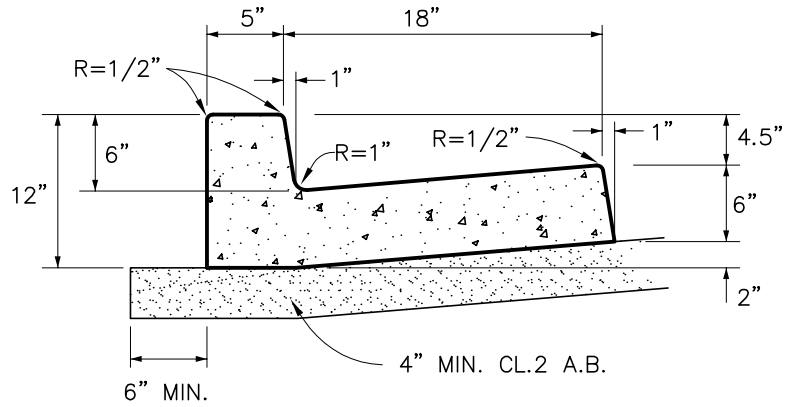

**STANDARD
CURB AND GUTTER**

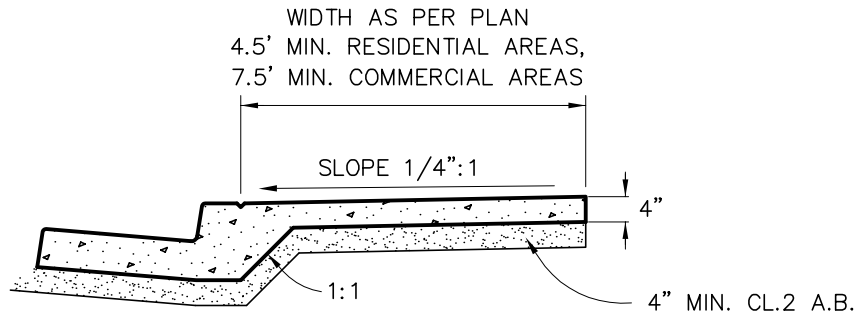

**TYPE 'A' SIDEWALK
PLACED MONOLITHIC WITH CURB**

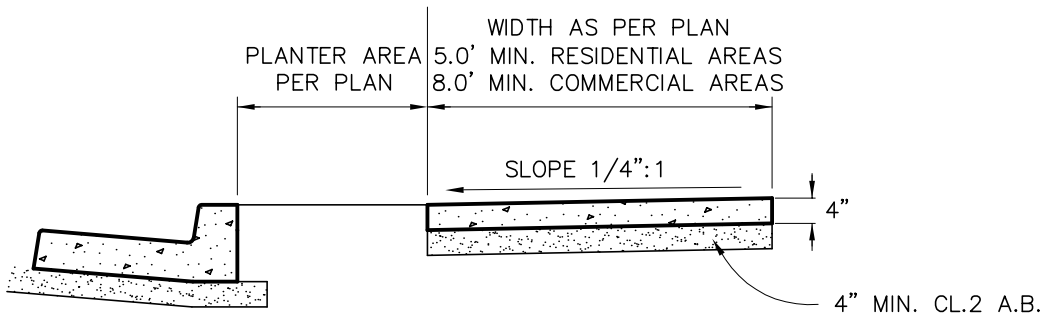

**TYPE 'B' SIDEWALK
PLACED SEPARATE FROM CURB**

SEE CURB, GUTTER AND SIDEWALK NOTES ON STANDARD A40B



CURB, GUTTER, SIDEWALK & MEDIAN

MENDOT
STD. NO.
A40A

SCALE: NONE | DESIGN: HND | DRAWN: HND | JUNE 2006

PAGE: A-34

NOTES:

1. CONCRETE SHALL BE CLASS 1, 1" MAXIMUM AGGREGATE SIZE PER CALTRANS STANDARD SPECIFICATIONS AND SHALL CONTAIN NOT LESS THAN 6 SACKS OF CEMENT PER CUBIC YARD. NO COLOR OR LAMP-BLACK SHALL BE ADDED UNLESS OTHERWISE SHOWN ON THE PLANS OR SPECIAL PROVISIONS.
2. EXPANSION JOINTS, 1/2 INCH WIDE, SHALL BE PLACED AT BOTH SIDES OF DRIVEWAY APPROACHES, AT EACH SIDE OF DRAINAGE STRUCTURES, AT ENDS OF CURB RETURNS, AND AT 60 FEET ON CENTER. EXPANSION JOINTS SHALL BE ALIGNED THROUGH ADJACENT CURB, GUTTER AND SIDEWALK.
3. WEAKENED PLANE JOINTS AT LEAST 1-1/2 INCH DEEP SHALL BE PLACED AT 15 FEET ON CENTER. WEAKENED PLANE JOINTS SHALL BE INSTALLED AT CENTER OF ALL DRIVEWAY APPROACHES OVER 20' WIDE.
4. SCORE MARKS AT LEAST 1/4 INCH DEEP SHALL BE PLACED AT BACK OF CURB AND IN ALL SIDEWALKS TO ESTABLISH AN EQUAL SQUARE PATTERN BASED ON THE SIDEWALK WIDTH. MAXIMUM SCORE MARK SPACING SHALL BE 5 FEET.
5. SUBGRADE SHALL BE COMPACTED TO AT LEAST 95% RELATIVE COMPACTION IN THE TOP 6 INCHES.
6. EXISTING CONCRETE TO BE REPLACED SHALL BE REMOVED AT EXPANSION JOINTS, WEAKENED PLANE JOINTS OR SCORE MARKS. CONCRETE REMOVED AT WEAKENED PLANE JOINTS OR SCORE MARKS SHALL BE SAWCUT. SAWCUTS SHALL BE AT LEAST 1-1/2 INCH DEEP.
7. NO UTILITY BOXES OR POLES SHALL BE PLACED IN THE SIDEWALK AREA WITHOUT THE WRITTEN APPROVAL OF THE DOT DIRECTOR.
8. NEW WORK SHALL MATCH EXISTING IN SCORE PATTERN AND COLOR.
9. NO CONCRETE SHALL BE PLACED UNTIL AFTER THE COUNTY INSPECTOR HAS APPROVED FORMS AND SUBGRADE.
10. ALL EXPOSED EDGES SHALL BE ROUNDED WITH 1/2 INCH RADIUS TOOL.
11. ALL SURFACES SHALL BE BROOM FINISHED.
12. ALL SIDEWALK CONSTRUCTED ADJACENT TO CURBS SHALL BE TYPE "A", PLACED MONOLITHIC WITH CURB, UNLESS OTHERWISE SHOWN ON THE PLANS OR SPECIAL PROVISIONS.
13. LANDSCAPE MAINTENANCE EASEMENTS (LME) SHALL BE MAINTAINED BY THE ENTITY TASKED WITH THAT RESPONSIBILITY THROUGH THE DEVELOPMENT PERMIT. SHOULD VEGETATION EVER POSE A SAFETY HAZARD THE MENDOCINO COUNTY ROAD COMMISSIONER RESERVES ALL OPTIONS UNDER CALIFORNIA STREETS AND HIGHWAYS CODE. SOME OPTIONS UNDER THE STREETS AND HIGHWAYS CODE ARE TO REMOVE THE VEGETATION OR CAUSE THE VEGETATION TO BE REMOVED BY OTHERS, *AT THE RESPONSIBLE PARTIES EXPENSE*. THE LANDSCAPE MAINTENANCE EASEMENT HOLDER SHALL BE CONSIDERED THE OWNER OF THE VEGETATION AND ALSO BE FINED FOR EACH DAY THE VEGETATION REMAINS IN PLACE AFTER DIRECTION BY THE ROAD COMMISSIONER TO REMOVE IT.
14. THE ROAD BASEMENT SOILS AND BASE ROCK SECTION SHALL BE PROTECTED FROM SUBSURFACE WATER BY DESIGN AND MAINTENANCE OF SURFACE AND SUBSURFACE WATER INTERCEPTORS IN THE LANDSCAPE MAINTENANCE EASEMENTS (LME). DAMAGE TO THE ROAD SECTION AS A RESULT OF IMPROPER MAINTENANCE OF THE LME SHALL BE REPAIRED AT THE EXPENSE OF THE ENTITY TASKED WITH THAT RESPONSIBILITY THROUGH THE DEVELOPMENT PERMIT.

NOTES REFER TO STANDARD A40A



**CURB, GUTTER, SIDEWALK & MEDIAN
LANDSCAPE MAINTENANCE NOTES**

MENDOT
STD. NO.
A40B

SCALE: NONE

DESIGN: HND

DRAWN: HND

JUNE 2006

PAGE: A-35

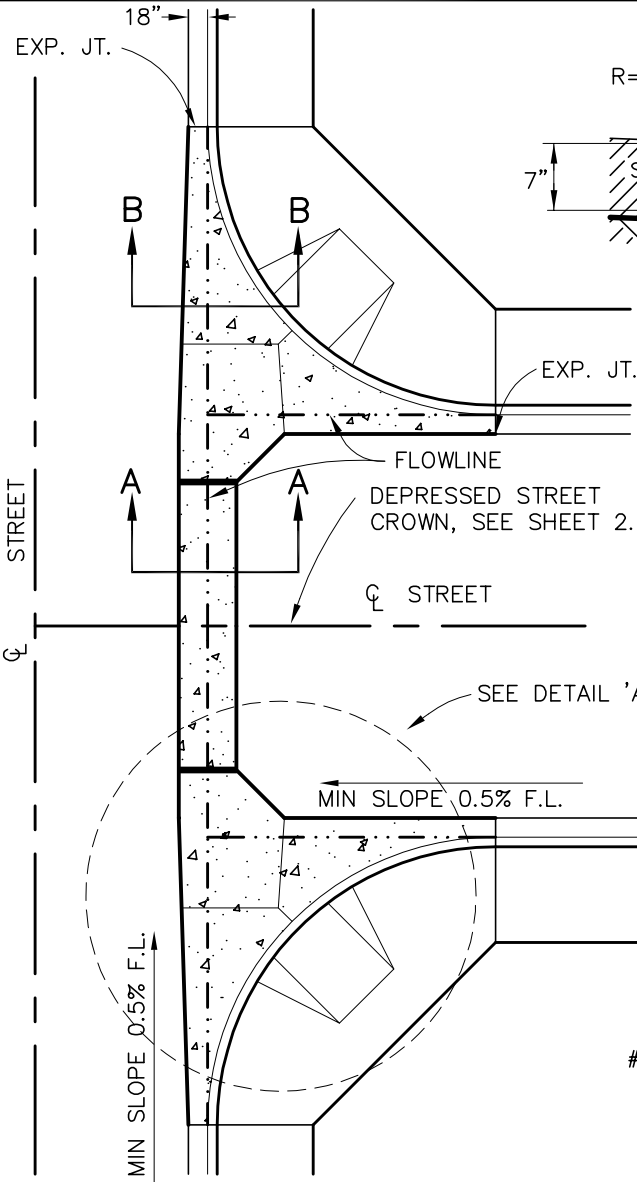

TYP. CROSS-GUTTER PLAN

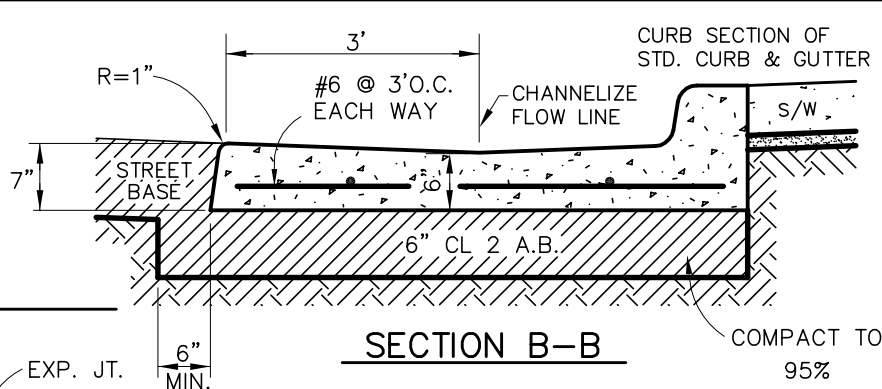

SECTION B-B

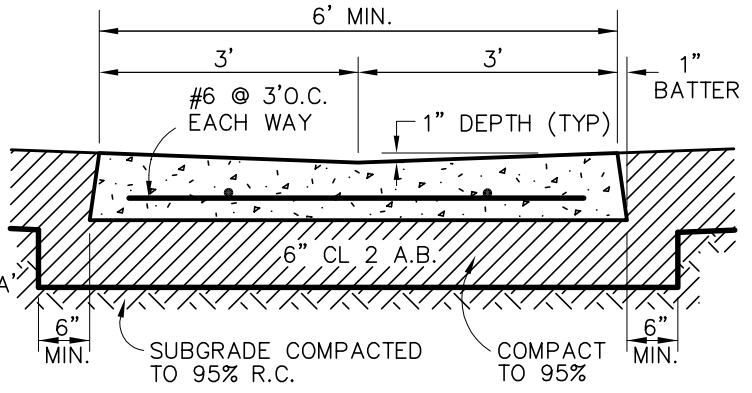

SECTION A-A

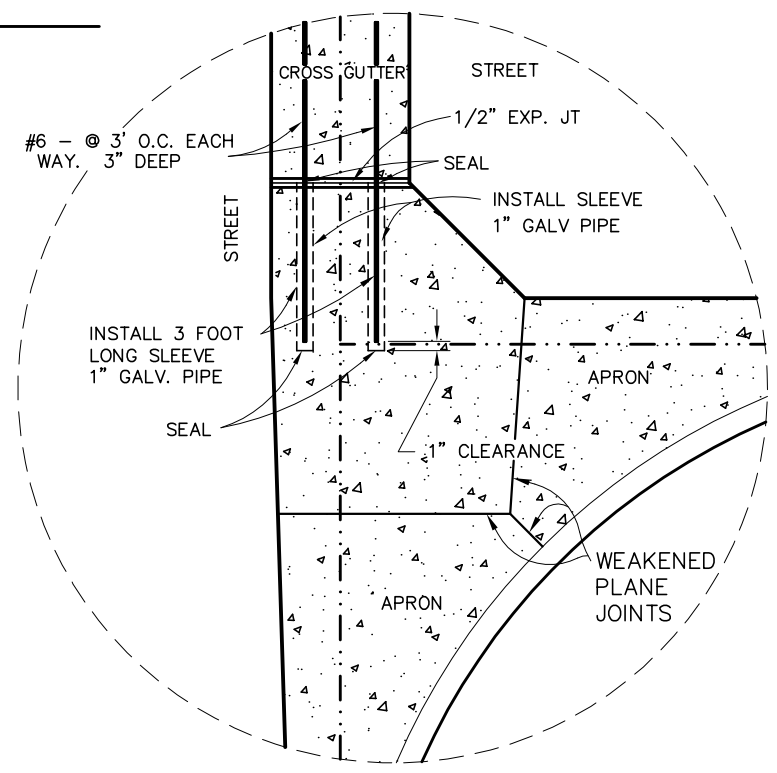

DETAIL "A"
TYPICAL BOTH SIDES

NOTE:

ALL CONCRETE SHALL BE CLASS "1"
(6 SACK/CU. YARD)

LEGEND

- EXP. JOINT 1/2" EXPANSION JOINT
- AREA OF APRON & CROSS GUTTER



VALLEY GUTTER

MENDOT
STD. NO.
A41A

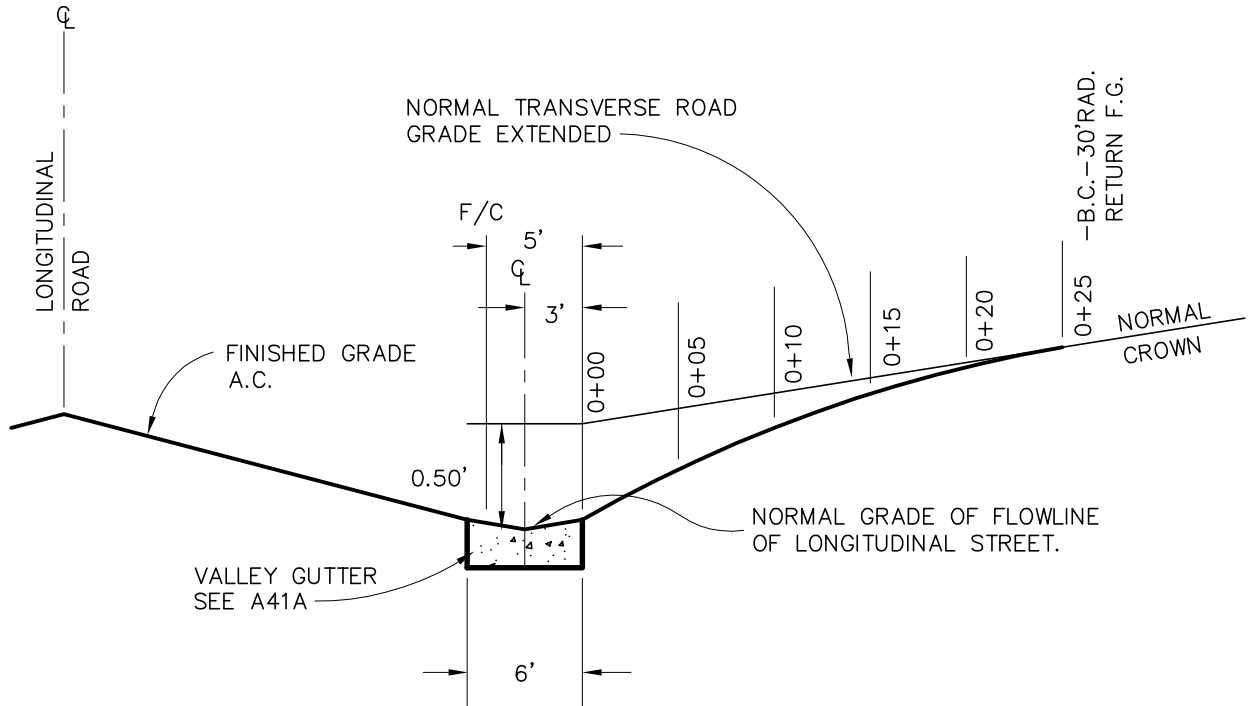

PROFILE ALONG CL TRANSVERSE ROAD

NOTE:

ORDINATES, IN DECIMAL PARTS OF A FOOT, ESTABLISH THE DISTANCE OF THE PAVEMENT SURFACE OF THE TRANSVERSE ROAD BELOW THE NORMAL ROAD GRADE, FROM STA 0+00 TO 0+25.

	A.C. SURFACING					
STA	0+00	0+05	0+10	0+15	0+20	0+25
ORDIN	0.42	0.31	0.20	0.09	0.02	0.00



**VALLEY GUTTER
ROAD PROFILE**

MENDOT
STD. NO.
A41B

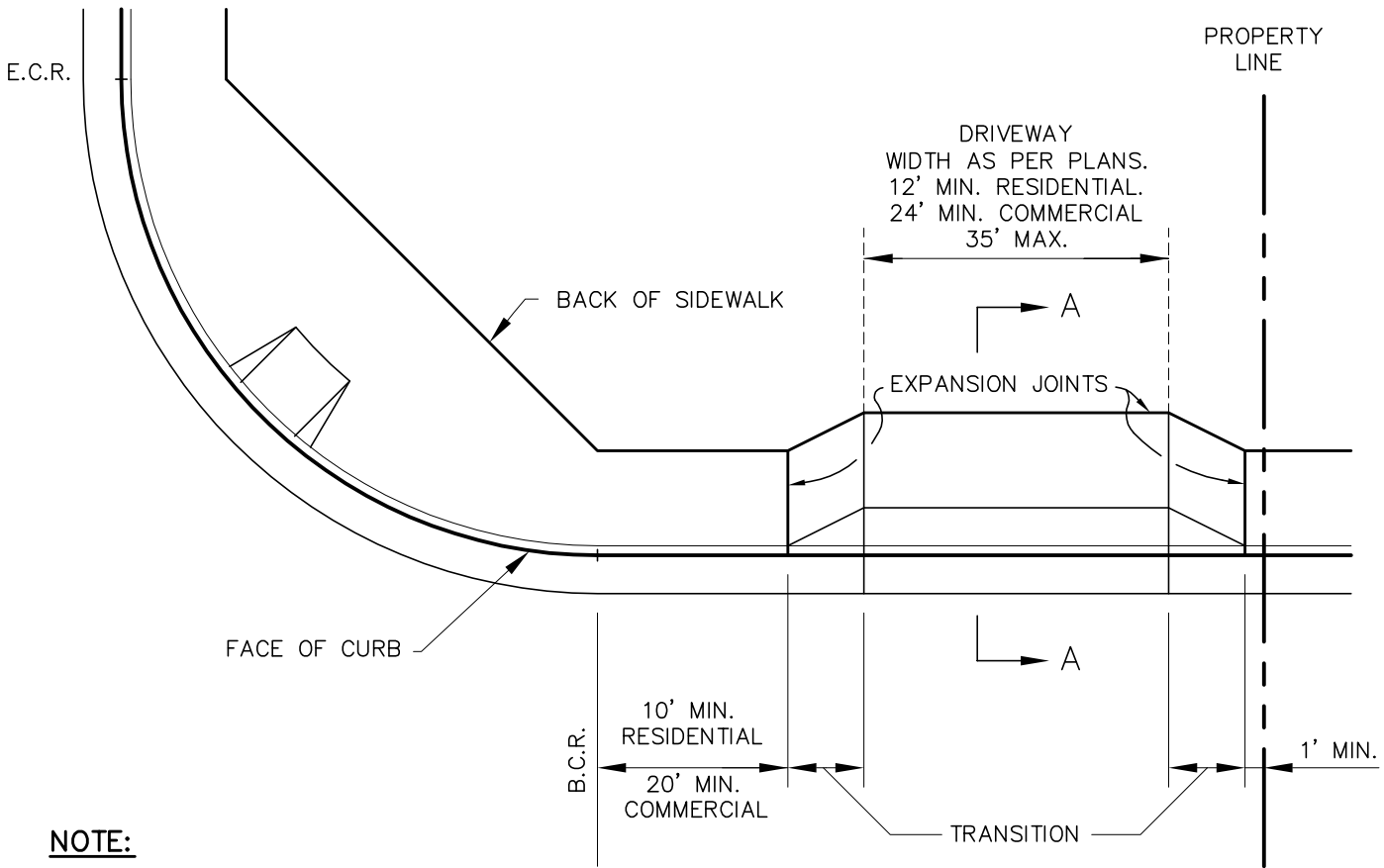

NOTE:

1. SEE MENDOT STD. NO. A40B FOR GENERAL NOTES.

PLAN

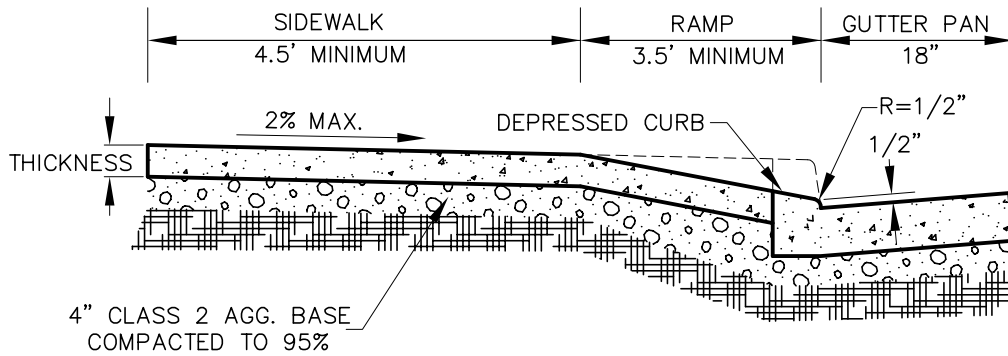

SECTION A-A

DRIVEWAY TYPE	THICKNESS	TRANSITION
RESIDENTIAL	6"	2'
COMMERCIAL	8"	4'



**DRIVEWAY APPROACH
URBAN ROADS**

MENDOT
STD. NO.
A50

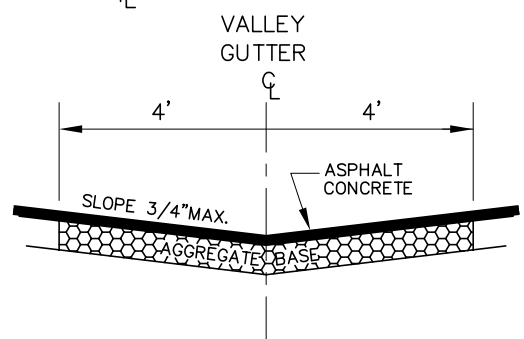
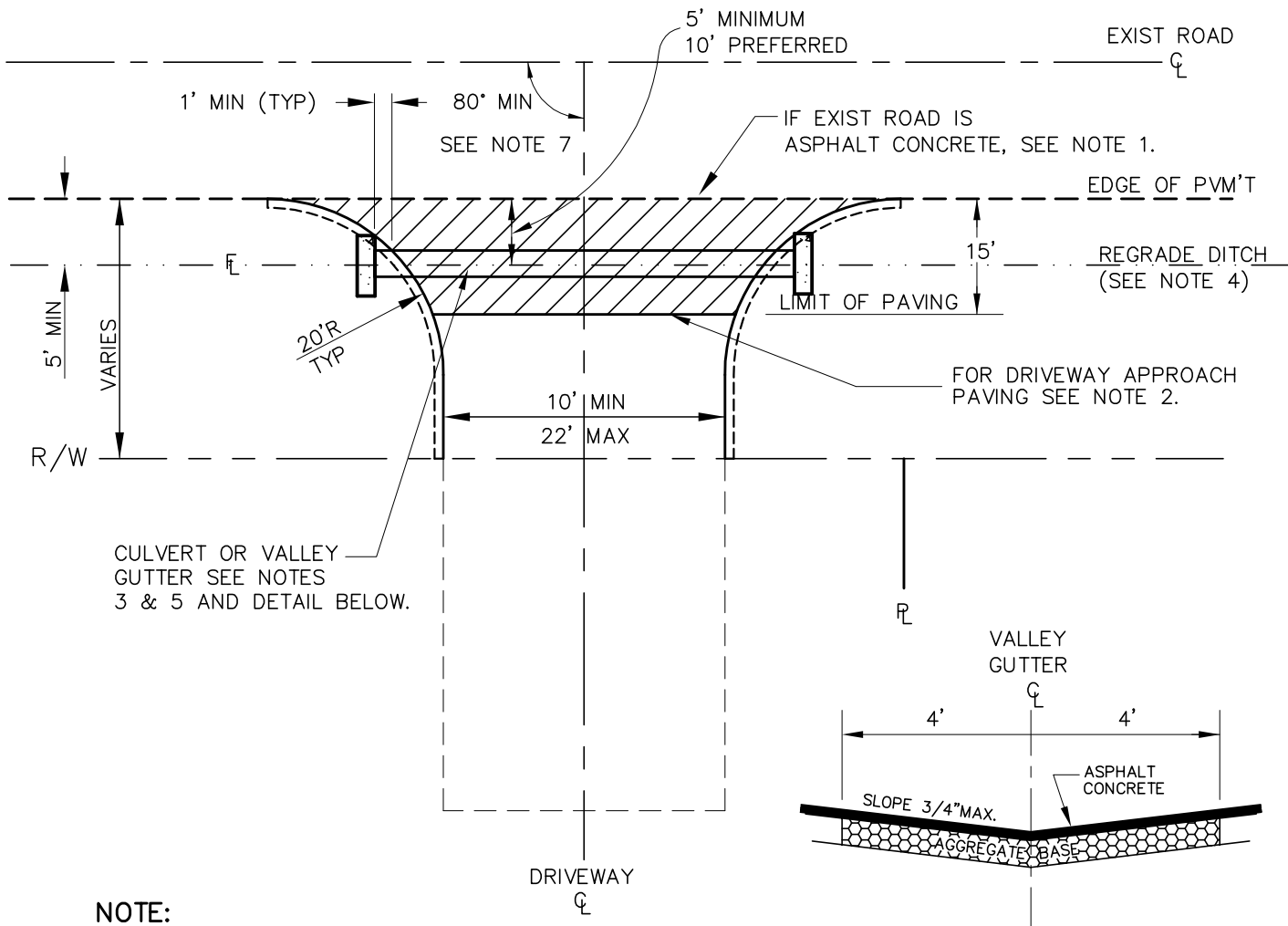

NOTE:
SEE STD. A51C FOR ALL REFERENCED NOTES.

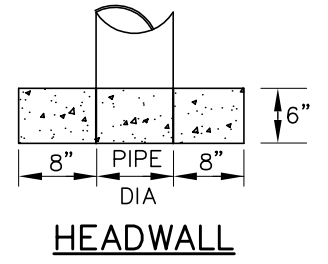
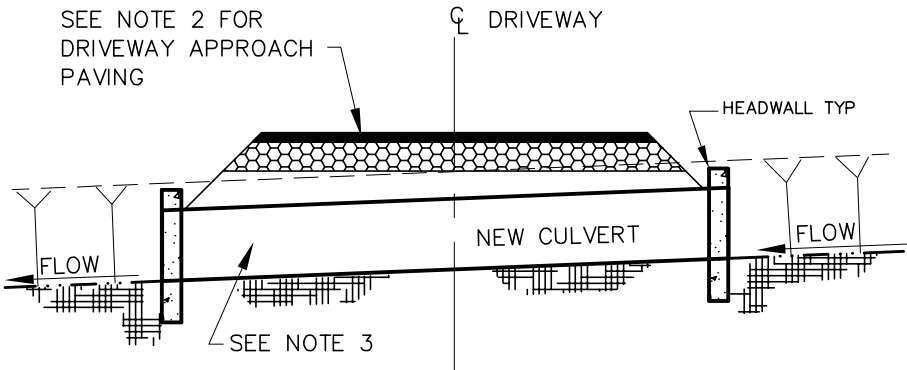
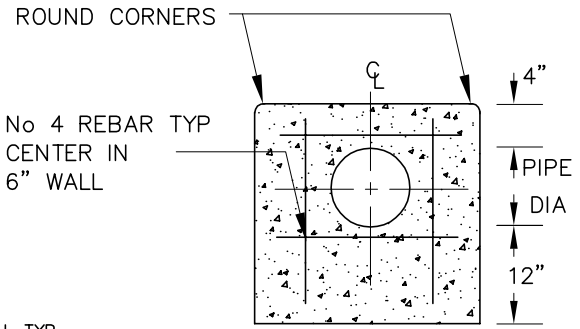

RESIDENTIAL DRIVEWAY APPROACH RURAL ROADS

MENDOT
STD. NO.
A51A

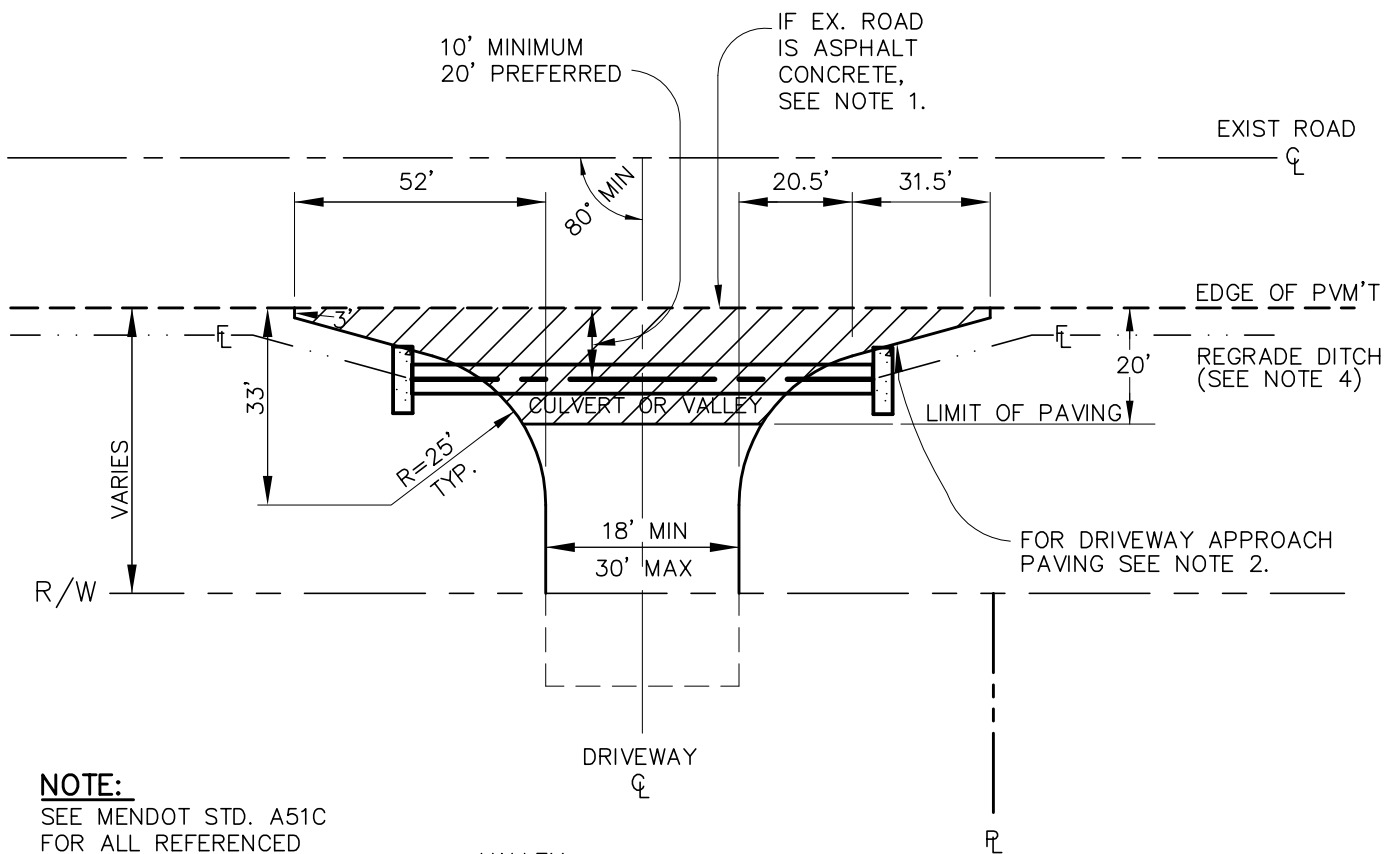

NOTE:
SEE MENDOT STD. A51C
FOR ALL REFERENCED
NOTES.

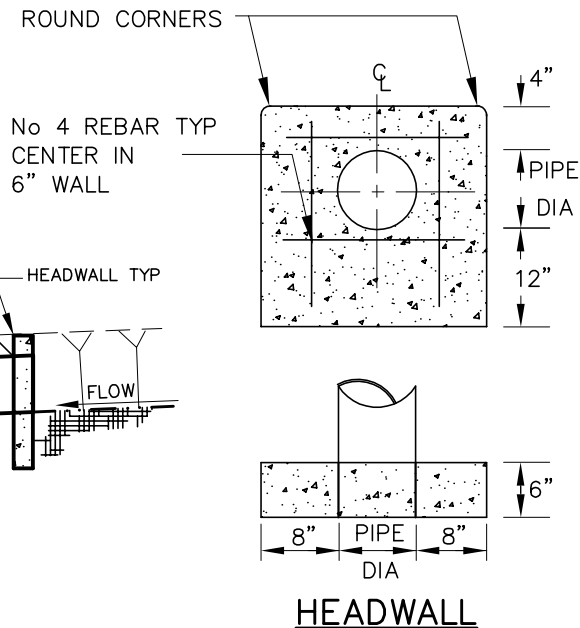
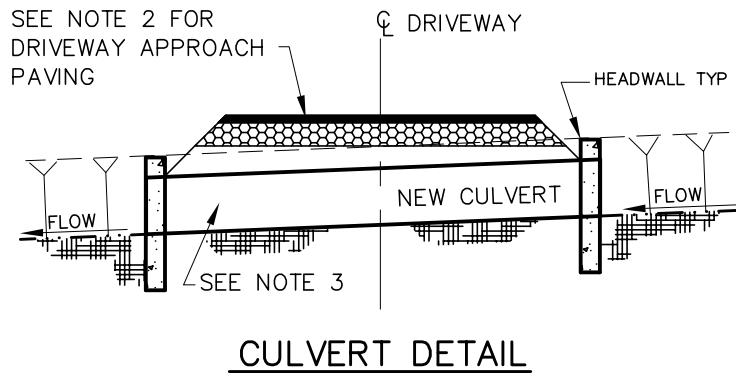
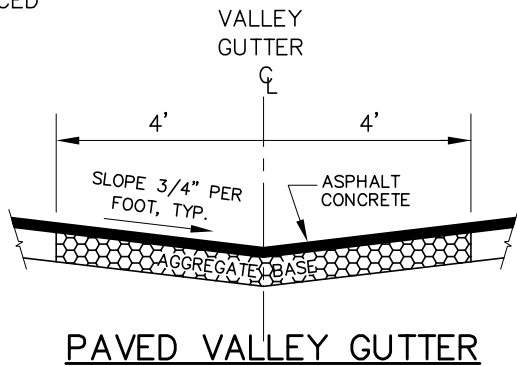

**COMMERCIAL DRIVEWAY
AND PRIVATE ROAD APPROACH
RURAL ROADS**

MENDOT
STD. NO.
A51B

NOTES:

1. NEATLY CUT EXIST. EDGE OF PAVEMENT AND APPLY TACK COAT.
2. RESIDENTIAL DRIVEWAY APPROACH MATERIAL SHALL BE ASPHALT CONCRETE IF ROAD FRONTING DRIVEWAY IS PAVED, PAVING SHALL CONSIST OF 2" A.C. OVER 6" A.B. MINIMUM.
3. COMMERCIAL DRIVEWAY AND PRIVATE ROAD APPROACH MATERIAL SHALL BE ASPHALT CONCRETE IF ROAD FRONTING THE APPROACH IS PAVED. PAVING SHALL CONSIST OF 3" A.C. OVER 8" CL. 2 A.B. MINIMUM.
4. DRIVEWAY APPROACH SURFACING SHALL BE COMPARABLE TO THE SURFACING OF THE ADJACENT ROAD. AGGREGATE BASE SHALL BE ONE FOOT WIDER THAN THE PAVED WIDTH ON EACH SIDE.
5. CULVERT SHALL BE 12" DIA. MIN. R.C.P. OR HDPE PLASTIC PIPE WITH SMOOTH INTERIOR WALL CONFORMING TO CALTRANS STANDARD SPECIFICATIONS. IN NO CASE SHALL PIPE BE SMALLER THAN UP STREAM CULVERT. LENGTH OF THE CULVERT SHALL BE THAT REQUIRED TO EXTEND ONE FOOT BEYOND THE TOE OF THE DRIVEWAY FILL.
6. REGRADE DITCH ADJACENT TO PROPERTY LINE FOR ENTIRE FRONTAGE OF PROPERTY, IF REQUIRED.
7. CULVERT SHALL BE REQUIRED WHERE THERE IS A ROADSIDE DITCH, UNLESS FLOWLINE OF DITCH IS LESS THAN 3" BELOW EDGE OF PAVEMENT PROFILE. VALLEY GUTTER SHALL BE PROVIDED WHERE CULVERT IS NOT REQUIRED (SEE DETAIL ON STD. NO. A51A)
8. ALL DRIVEWAYS SHALL INTERSECT EXIST STREETS AT 80' MINIMUM, UNLESS OTHERWISE APPROVED BY THE DOT DIRECTOR.
9. SEE MENDOT STD NO. A52 FOR DRIVEWAY/ROAD CONNECTION PROFILE.
10. SEE MENDOT STD NO. A53 FOR SIGHT DISTANCE REQUIREMENTS.
11. AN ENCROACHMENT PERMIT SHALL BE OBTAINED PRIOR TO CONSTRUCTING A DRIVEWAY APPROACH ON A COUNTY ROAD.
12. CULVERT SIZE AND MATERIAL SUBJECT TO THE APPROVAL OF COUNTY



**DRIVEWAY APPROACH
RURAL ROADS – NOTES**

MENDOT
STD. NO.
A51C

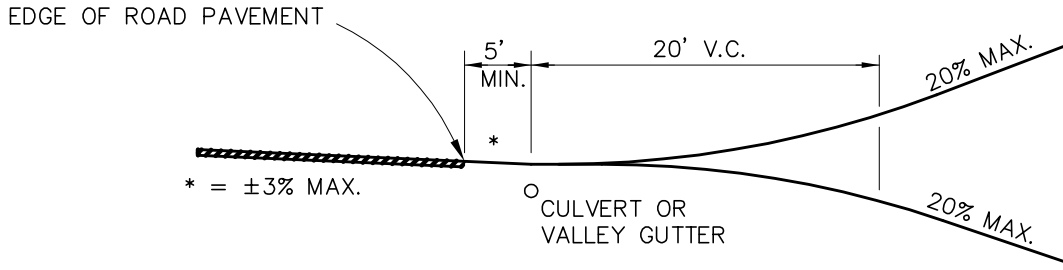

RURAL ROADS/RESIDENTIAL DRIVEWAYS

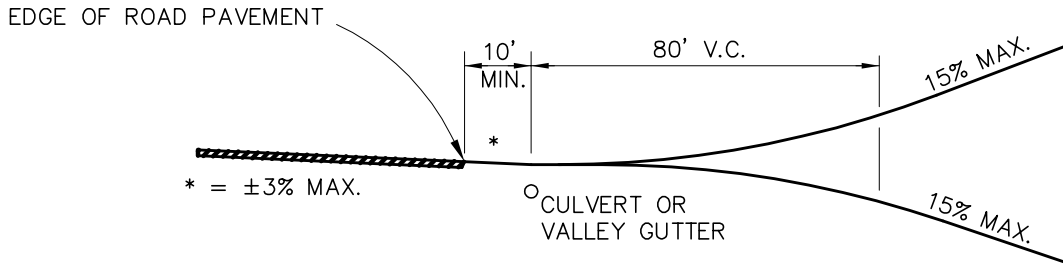

RURAL ROADS/COMMERCIAL DRIVEWAYS AND PRIVATE ROADS

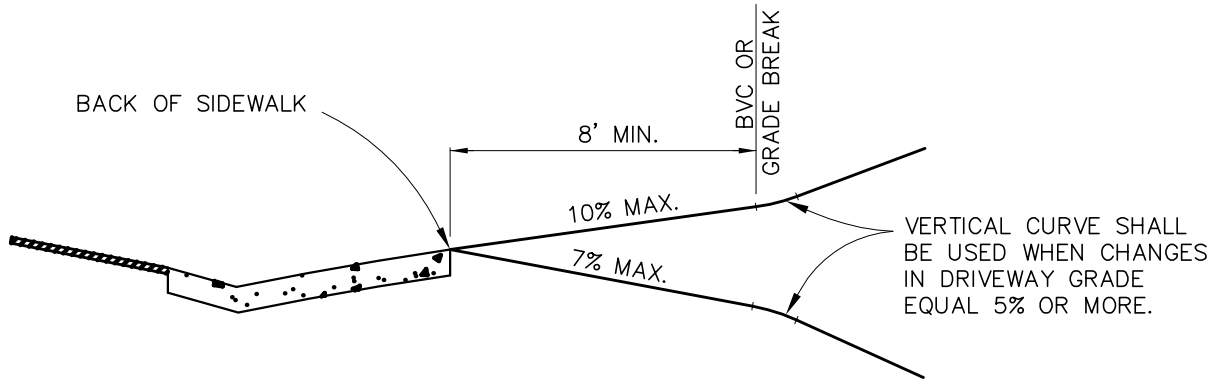

URBAN ROADS/RESIDENTIAL DRIVEWAYS

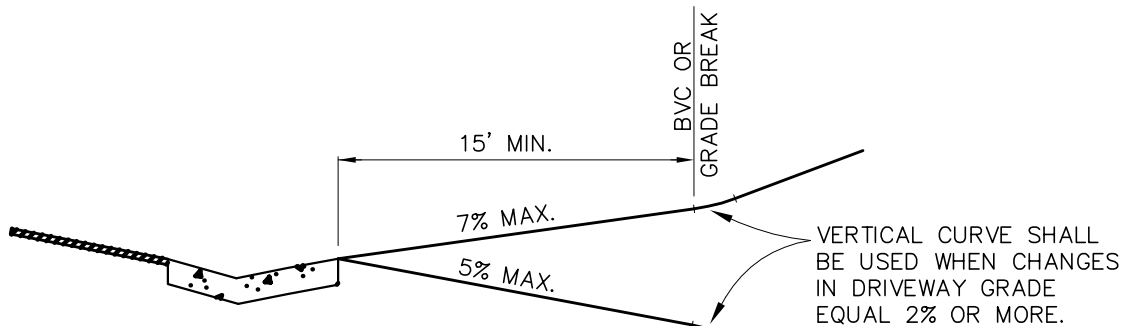

URBAN ROADS/ COMMERCIAL DRIVEWAYS



DRIVEWAY APPROACH
PROFILES

MENDOT
STD. NO.
A52

NOTE: SIGHT DISTANCE FOR THE CRITICAL APPROACH SHALL MEET THE MINIMUM STOPPING SIGHT DISTANCE SET BY THE CALTRANS DESIGN MANUAL

85% PREVAILING SPEED	"D" *
25	150'
30	200'
35	250'
40	300'
45	360'
50	430'
55	500'
60	580'
65	660'

* MAY INCREASE BY 20% ON SUSTAINED DOWNGRADES IN EXCESS OF 3% AND OVER 1 MILE IN LENGTH AS WARRANTED.

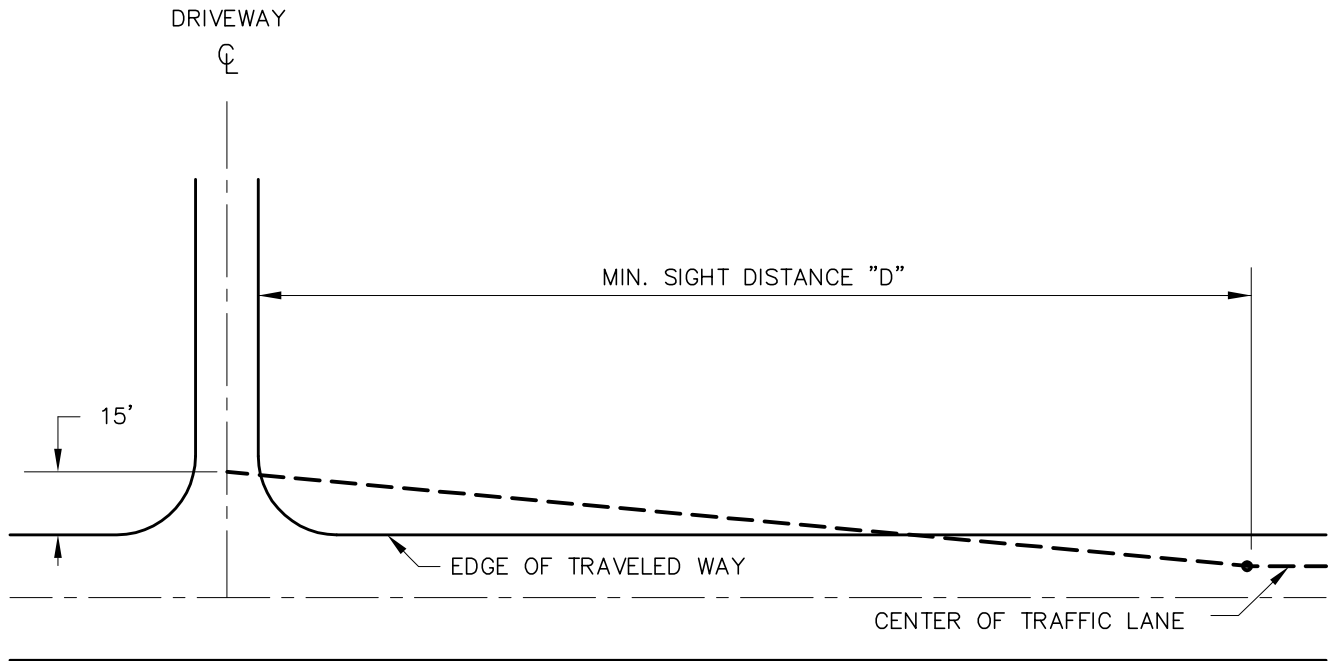

DRIVEWAY APPROACH MINIMUM STOPPING SIGHT DISTANCE

MENDOT
STD. NO.
A53

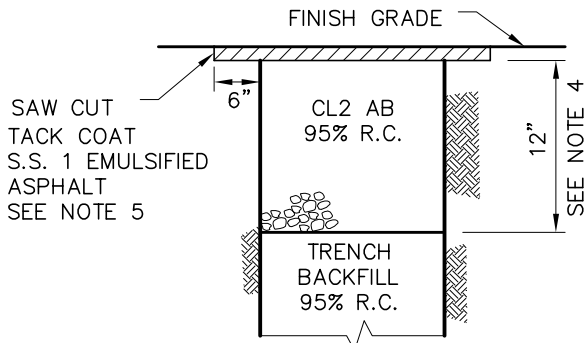

TYPE A

(EXISTING ROAD OR PAVED SHOULDERS)

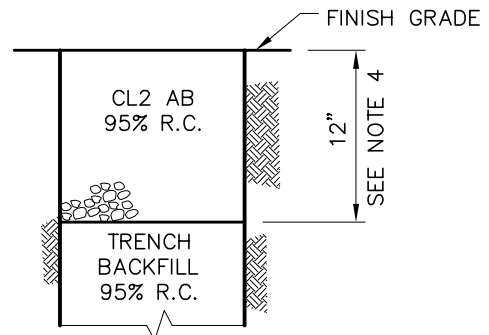

TYPE B

(UNPAVED SHOULDER AREAS)

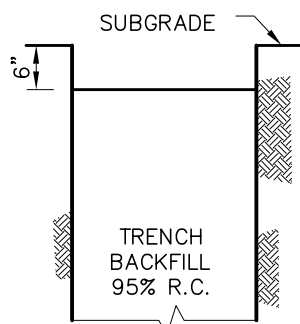

TYPE C

(ROADS UNDER CONSTRUCTION)

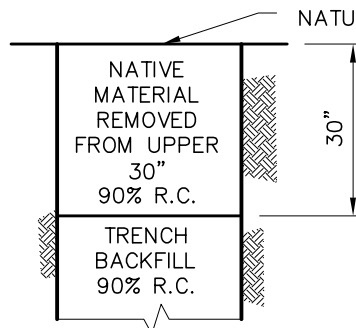

TYPE D

(PUBLIC UTILITY EASEMENTS)
(OUTSIDE ROAD AREA)

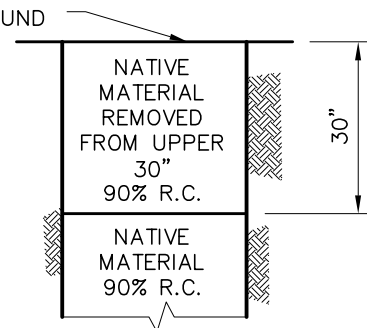

TYPE E

(PUBLIC UTILITY EASEMENTS)
(UNDEVELOPED AREAS)

TRENCH BACKFILL AND SURFACING

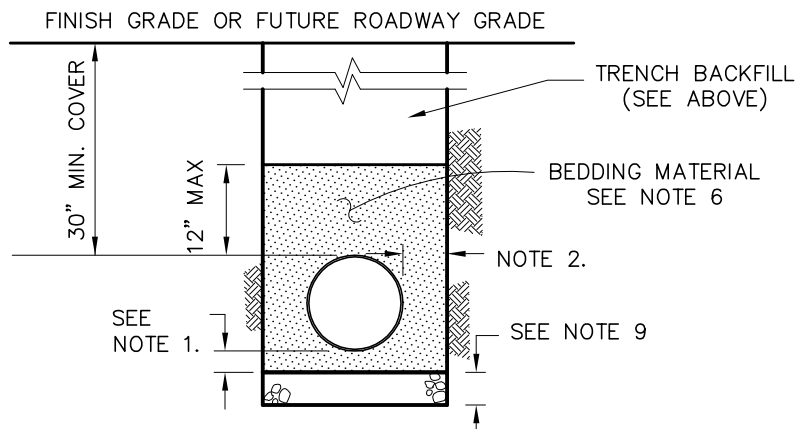

PIPE BEDDING

NOTE:

SEE MENDOT STD. A60B AND A60C FOR ALL TRENCH RESTORATION NOTES.



TRENCH RESTORATION SECTIONS

MENDOT
STD. NO.
A60A

TRENCH RESTORATION NOTES:

1. BEDDING BELOW PIPE SHALL BE AS REQUIRED BY UTILITY OR AGENCY THAT OWNS THE FACILITY.
2. 12" MIN., OR 6" MIN. IF SLURRY CEMENT BACKFILL IS USED. SEE NOTE 10.
3. RELATIVE COMPACTION DESIGNATED R.C.
4. THE MINIMUM ROAD STRUCTURAL SECTION SHALL BE A MIN. OF 3" A.C. ON 12" CL. 2 A.B. OR SHALL MATCH EXISTING PAVEMENT THICKNESS WHICHEVER IS THICKER, UNLESS OTHERWISE SHOWN ON THE PLANS. STRUCTURAL SECTION IN SHOULDERS SHALL MATCH EXISTING AND SHALL BE A MIN. OF 8" CL. 2 A.B.
5. NEATLY CUT PAVEMENT SIX INCHES FROM EDGE OF TRENCH AFTER TRENCH IS BACKFILLED. SS1 DESIGNATES SS1 ASPHALTIC EMULSION PER CALTRANS STANDARD SPECIFICATION, SECTION 94, ASPHALTIC EMULSION.

6. MATERIAL SPECIFICATIONS

- 6a. DRAIN ROCK SHALL BE EITHER OF THE NOMINAL SIZES DESIGNATED AS 1-1/2" BY 3/4" OR 2-1/2" BY 1-1/2".
- 6b. PIPE BEDDING AND TRENCH BACKFILL MATERIAL SHALL BE A WELL GRADED GRAVEL/SAND MATERIAL AND SHALL HAVE A MINIMUM SAND EQUIVALENT VALUE OF 20 AND SHALL CONFORM TO THE FOLLOWING GRADINGS:

	<u>PERCENT PASSING</u>						
	<u>3"</u>	<u>3/4"</u>	<u>3/8"</u>	<u>NO. 4</u>	<u>NO. 16</u>	<u>NO. 30</u>	<u>NO. 200</u>
PIPE BEDDING		100	80-100	10-50	5-30		0-4
TRENCH BACKFILL	100			35-100		20-100	

- 6c. IN ADDITION, WHEN TESTED WITH THE FOLLOWING SERIES OF SIEVES, NO MORE THAN 25% OF THE MATERIAL WILL BE RETAINED BETWEEN ANY ADJACENT SIEVES: 3", 2-1/2", 2", 1-1/2", 1", 3/4", 1/2", 3/8", NO. 4, NO. 8, NO. 16, NO. 30, NO. 50, NO. 100, AND NO. 200.
- 6d. **AGGREGATE BASE** CL 2 A.B. DESIGNATES CLASS 2 AGGREGATE BASE AND SHALL CONFORM TO THE PROVISIONS OF SECTION 26 OF THE COUNTY STANDARD SPECIFICATIONS.
- 6e. **NATIVE MATERIAL** SHALL NOT CONTAIN ROCKS LARGER THAN 3".



**TRENCH RESTORATION
NOTES**

MENDOT
STD. NO.
A60B

- 7. **COMPACTION REQUIREMENTS:** (AS SHOWN ON A60A AND IN THE FOLLOWING MODIFICATIONS)
 - 7a. **DRAIN ROCK** SHALL BE CONSOLIDATED WITH VIBRATORY COMPACTION EQUIPMENT TO A MINIMUM R.C. OF 90%.
 - 7b. **PIPE BEDDING MATERIAL** SHALL BE CONSOLIDATED WITH VIBRATORY COMPACTION EQUIPMENT TO A MINIMUM R.C. OF 90%.
 - 7c. **GENERAL:** THE COMPACTION REQUIREMENTS SHALL BE ACHIEVED UTILIZING METHODS AND EQUIPMENT APPROVED BY THE COUNTY. ANY METHOD OF COMPACTION WHICH FAILS TO UNIFORMLY ACHIEVE THE REQUIRED LEVELS OF COMPACTION THROUGHOUT THE LENGTH AND DEPTH OF TRENCHES SHALL BE DISCONTINUED. COMPACTION METHODS AND EQUIPMENT SHALL BE SUCH AS NOT TO DAMAGE THE INSTALLED PIPE, EXCEED ITS LOADING CAPACITY OR DISTURB ITS ALIGNMENT. FLOODING, PONDING OR JETTING WILL NOT BE ALLOWED.
 - 7d. **MECHANICAL COMPACTION:** TRENCH BACKFILL SHALL BE PLACED IN UNIFORM, HORIZONTAL LAYERS NOT EXCEEDING EIGHT (8) INCHES IN THICKNESS BEFORE COMPACTION. EACH LAYER SHALL BE COMPACTED, USING MECHANICAL MEANS, TO THE SPECIFIED DENSITY SHOWN ON THE PLANS.

THE CONTRACTOR MAY, AT CONTRACTOR'S SOLE OPTION AND AT CONTRACTOR'S SOLE EXPENSE, CONSTRUCT A TEST TRENCH SECTION WHICH DEMONSTRATES METHODS, EQUIPMENT, OR MATERIALS WHICH WILL RELIABLY ACHIEVE THE REQUIRED COMPACTION IN LIFTS GREATER THAN 8 INCHES. AT ITS SOLE DISCRETION, THE COUNTY MAY INCREASE THE MAXIMUM ALLOWABLE LIFT THICKNESS PERMITTED BASED UPON THE RESULTS DEMONSTRATED BY THE TEST TRENCH SECTION. SHOULD SUBSEQUENT TESTING DEMONSTRATE THAT THE REQUIRED COMPACTION IS NOT BEING RELIABLY ACHIEVED, THE COUNTY MAY, AT ITS SOLE DISCRETION, REDUCE THE MAXIMUM LIFT THICKNESS TO ITS ORIGINAL VALUE OF 8 INCHES.

- 8. **TRENCHING METHODS:** ROCK WHEEL TRENCHING SHALL BE ALLOWED FOR TRENCH CONSTRUCTION IN COUNTY ROADS. INSTALLATION OF CABLE USING THE PLOW METHOD SHALL NOT BE ALLOWED.
- 9. **TRENCH BASE:** TRENCH BASE SHALL BE STABILIZED USING ADDITIONAL PIPE BEDDING; DRAIN ROCK, OR OTHER SUITABLE MATERIAL AS DIRECTED BY UTILITY, COUNTY DOT, OR CIVIL ENGINEER IN RESPONSIBLE CHARGE OF THE WORK.
- 10. **SLURRY CEMENT BACKFILL:** SLURRY CEMENT BACKFILL MAY BE USED FOR TRENCH BACKFILL ONLY AS AUTHORIZED BY COUNTY DOT, BUT SHALL BE REQUIRED WHEN TRENCH WIDTHS OF LESS THAN 12 INCHES ARE REQUESTED. SLURRY CEMENT BACKFILL SHALL MEET THE REQUIREMENTS OF SECTION 19-3.062, SLURRY CEMENT BACKFILL, OF THE CALTRANS STANDARD SPECIFICATIONS, UNLESS COUNTY DOT DIRECTOR APPROVES A SPECIFIC MIX DESIGN.



TRENCH RESTORATION NOTES (CONTINUED)

MENDOT
STD. NO.
A60C

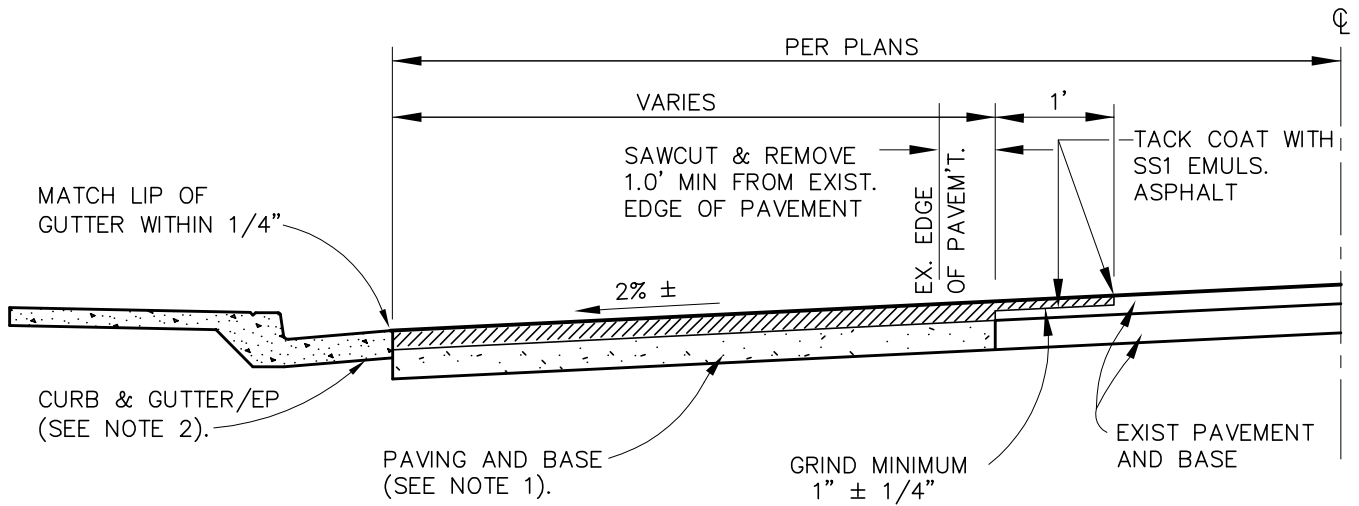

NOTES:

1. PAVING AND BASE THICKNESS TO BE DETERMINED USING COUNTY PAVEMENT DESIGN STANDARDS. MINIMUM PAVEMENT THICKNESS TO BE 2-1/2".
2. SEE MENDOT STD. A40A FOR CURB GUTTER & SIDEWALK DETAILS.
3. WHEN CURB, GUTTER AND SIDEWALK ARE NOT REQUIRED, REVERT TO MENDOT STD. A18 FOR TYPICAL SHOULDER CONSTRUCTION.



**ROAD WIDENING/PAVEOUT
DETAIL**

MENDOT
STD. NO.
A70

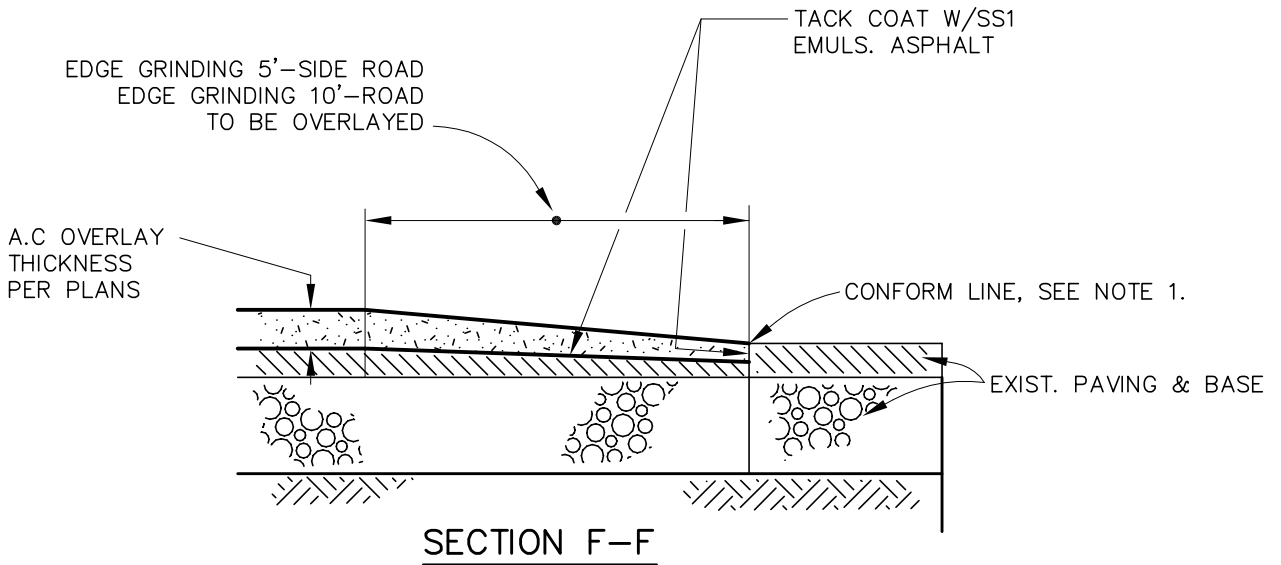
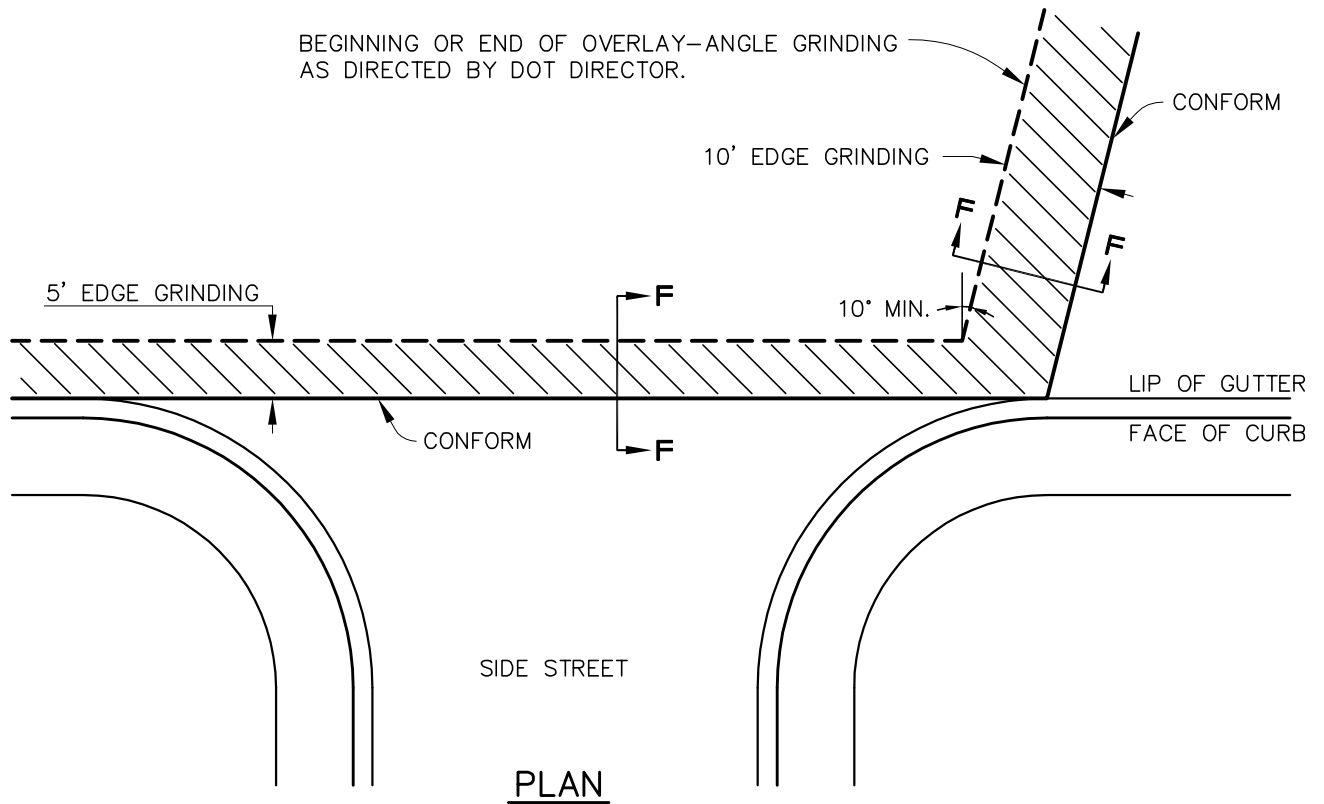

NOTES:

1. EDGE GRINDING SHALL BE A MINIMUM OF 1"±1/4".
2. DESIGN SHALL CONFORM TO THESE REQUIREMENTS EXCEPTS AS OTHERWISE APPROVED BY THE DOT DIRECTOR.



**PAVEMENT REPAIR DETAIL —
SIDE ROAD/
END OF OVERLAY CONFORM**

MENDOT
STD. NO.
A71

SCALE: NONE | DESIGN: RCW | DRAWN: LMM | OCT. 2000

PAGE: A-48

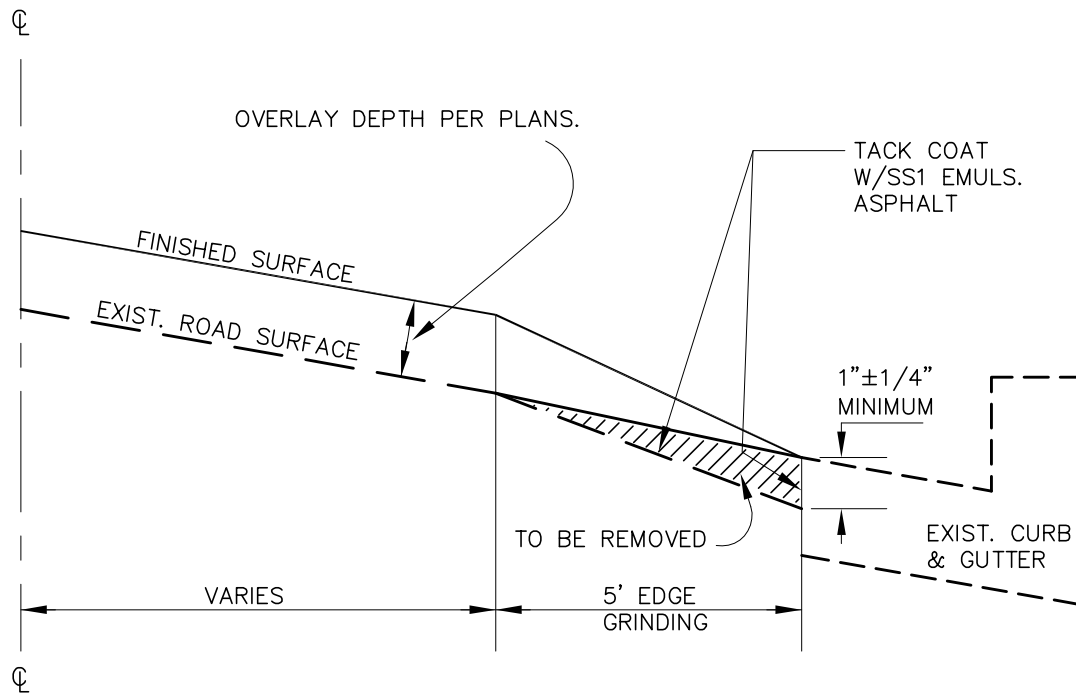

NOTES:

1. DESIGN SHALL CONFORM TO THESE REQUIREMENTS EXCEPT AS OTHERWISE APPROVED BY THE DOT DIRECTOR.
2. MAXIMUM CROSS SLOPE SHALL BE 5%.



**PAVEMENT REPAIR DETAIL –
EDGE GRINDING AT
LIP OF GUTTER**

MENDOT
STD. NO.
A72

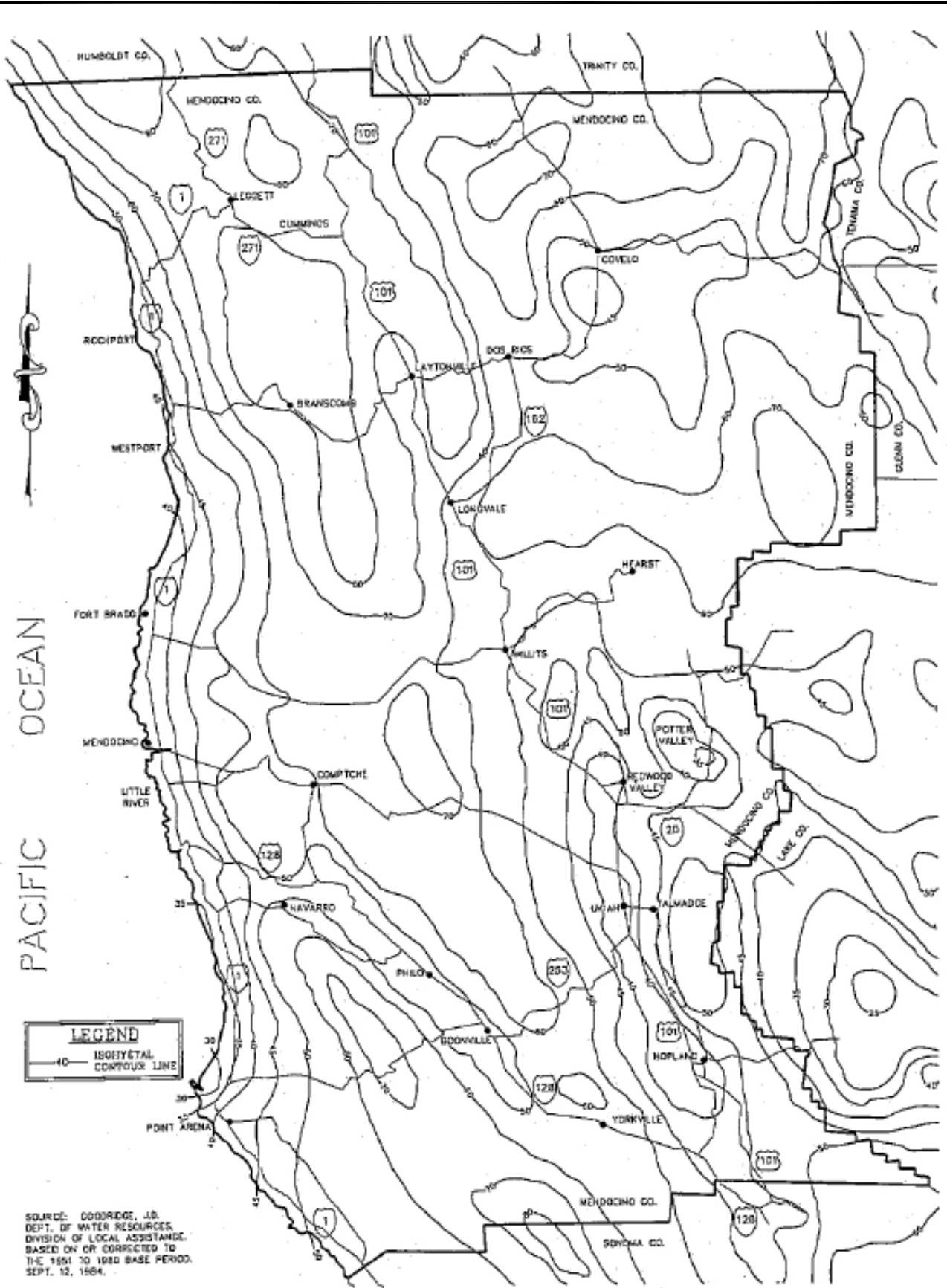

MEAN SEASONAL PRECIPITATION IN INCHES

MENDOT
STD. NO.
D10

1. THE FOLLOWING INTENSITY/DURATION/FREQUENCY (IDF) CURVES WERE OBTAINED FROM THE CALIFORNIA DEPARTMENT OF TRANSPORTATION IN JUNE, 2000, AND ARE BASED ON THEIR IDF32 SOFTWARE PACKAGE, WHICH IS NOTED AS FOLLOWS:

*IDF32
Caltrans Rainfall Intensity Program
Copyright 1998
Department of Transportation
State of California*

This program is freeware. There are no restrictions on its distribution.

NOTICE: This software does not necessarily reflect the official views or policy of the California Department of Transportation or the California Department of Water Resources. While the data and methodology contained herein is believed to be accurate, the State of California or local agencies assume no liability arising from errors, omissions, or other defects in this software. This software does not constitute a standard, a specification or a regulation.

2. THE SOFTWARE INCLUDES IDF CURVES FOR THE FOLLOWING LOCATIONS IN OR NEAR MENDOCINO COUNTY:

RAINFALL STATION	ELEVATION	LATITUDE	LONGITUDE	YEARS OF DATA
CASPER CREEK 4	240	39.348	123.753	1963-1978
CASPER CREEK 5	400	39.357	123.736	1965-1978
COVELO EEL RIVER	1514	39.833	123.083	1941-1985
FORT BRAGG	80	39.446	123.807	1940-1985
HOPLAND 8 NE	2510	39.017	123.000	1944-1975
LAYTONVILLE	1640	39.700	123.483	1941-1986
LEGETT	700	39.867	123.717	1972-1986
NAVARRO 1 NW	220	39.164	123.563	1954-1986
POINT ARENA	122	38.917	123.700	1940-1986
POTTER VALLEY 3 NNW	1060	39.367	123.133	1953-1964
POTTER VALLEY 3 SE	1100	39.300	123.067	1953-1982
POTTER VALLEY POWERHOUSE	1014	39.367	123.133	1965-1986
REDWOOD VALLEY	718	39.267	123.200	1938-1971
UKIAH-LAKE MENDOCINO DAM	670	39.233	123.183	1972-1986
UKIAH-MASONITE	615	39.167	123.200	1953-1957
WILLITS HOWARD	1925	39.350	123.317	1940-1986
YORKVILLE	1120	38.917	123.267	1940-1986



**INTENSITY/DURATION/FREQUENCY CHARTS
NOTES**

MENDOT
STD. NO.
D11A

3. FOR EASE OF USE, SIX IDF CURVES HAVE BEEN REPRODUCED IN THESE ROAD STANDARDS, REPRESENTING A RANGE OF GEOGRAPHICAL AREAS AND RAINFALL INTENSITIES; THESE CURVES ARE SHOWN IN BOLD ABOVE. THE ENGINEER IN RESPONSIBLE CHARGE OF THE WORK SHALL USE JUDGMENT TO DETERMINE THE APPROPRIATE IDF FOR THE DRAINAGE SITE. THE FOLLOWING GUIDANCE IS PROVIDED FROM CALTRANS' IDF PROGRAM REGARDING INTERPOLATION:

To obtain the best IDF curve for the drainage site, the user must use judgment to determine if an IDF curve from one nearby station or an interpolation of curves from more than one station is appropriate. it is recommended that for drainage sites in hilly or mountainous terrain that the site and nearby stations be plotted on USGS 7.5- or 15- minute quadrangle maps, to facilitate visualization of the relationship of the site, the rainfall stations and the terrain. The following should be considered:

Station within a few miles of site - If there is a rainfall station fairly close by, a single-station IDF curve is most likely best. Averaging in data from more distant stations using interpolation will only 'dilute' the quality of the curve.

Intervening Mountains or Ranges - The rainfall intensity of a site can be strongly influenced by 'orographic influence.' Typically, the west side of mountains will be wetter than the east side; this is due to prevailing westerlies during winter storms and the thermodynamic properties of moist air as it ascends mountain ranges. In California, rainfall intensities can vary sharply in the space of a few miles. Use judgment before accepting IDF data from a station that is located on the opposite side of a ridge from your drainage site.

Elevation differences - The elevation of the stations are provided for information; elevations are not a factor in program calculations. Before accepting IDF data from a station, compare elevations between site and station. Be wary of elevation differences greater than 1000 feet.

4. TO OBTAIN A COPY OF THE IDF 32 PROGRAM, CONTACT CALTRANS, 1120 N. STREET, PO BOX 942874, SACRAMENTO, CA 94274-0001.



**INTENSITY/DURATION/FREQUENCY CHARTS
NOTES (CONTINUED)**

MENDOT
STD. NO.
D11B

SCALE: NONE | DESIGN: RCW | DRAWN: LMM | OCT. 2000

PAGE: A-52

INTENSITY-DURATION-FREQUENCY CHART

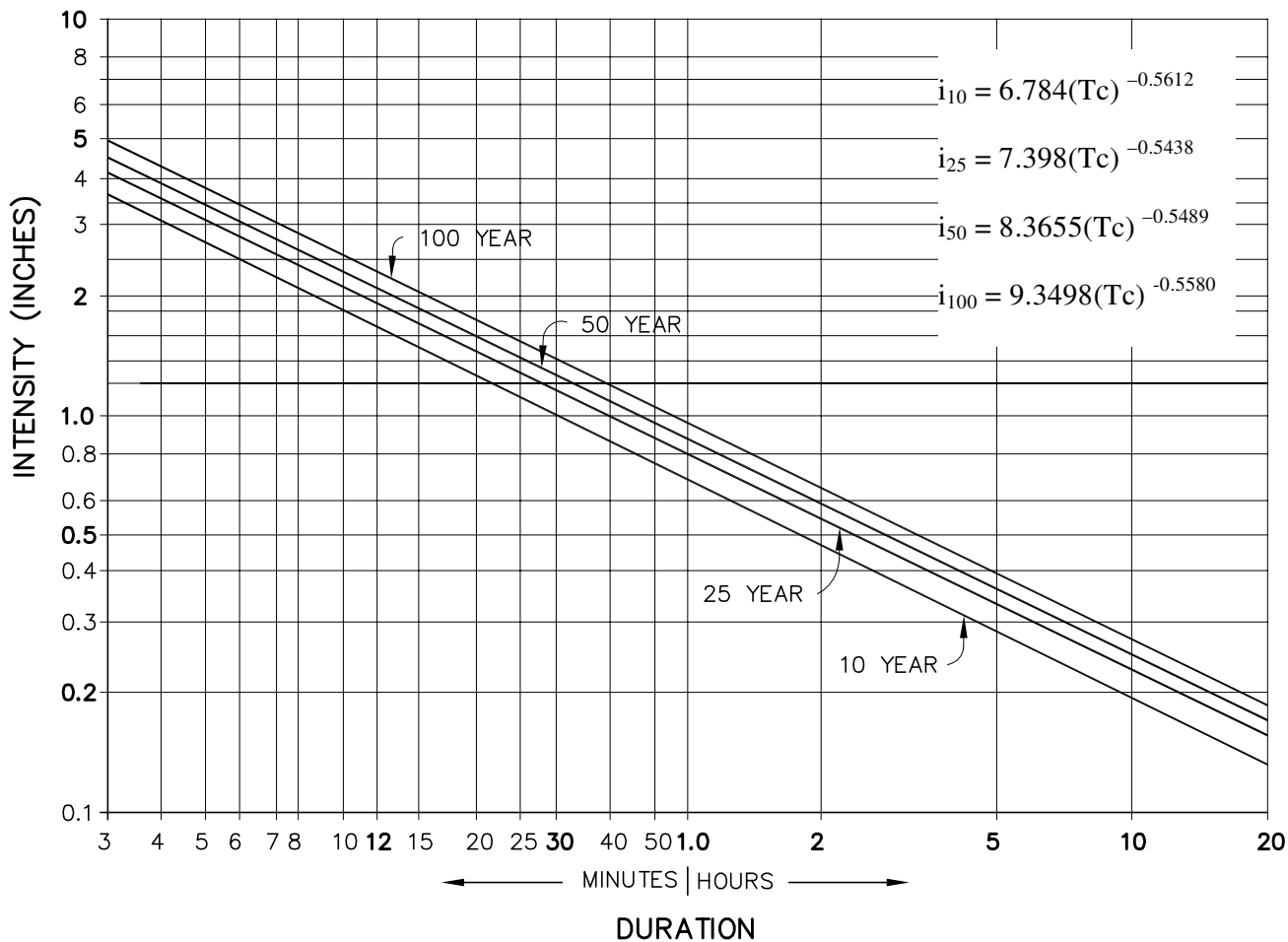

STATION DATA	
LONGITUDE:	123.083
LATITUDE:	39.833
ALTITUDE:	1514
YEARS OF DATA:	1941-1985



INTENSITY/DURATION/FREQUENCY CHART COVELO EEL RIVER

MENDOT
STD. NO.
D11C

INTENSITY-DURATION-FREQUENCY CHART

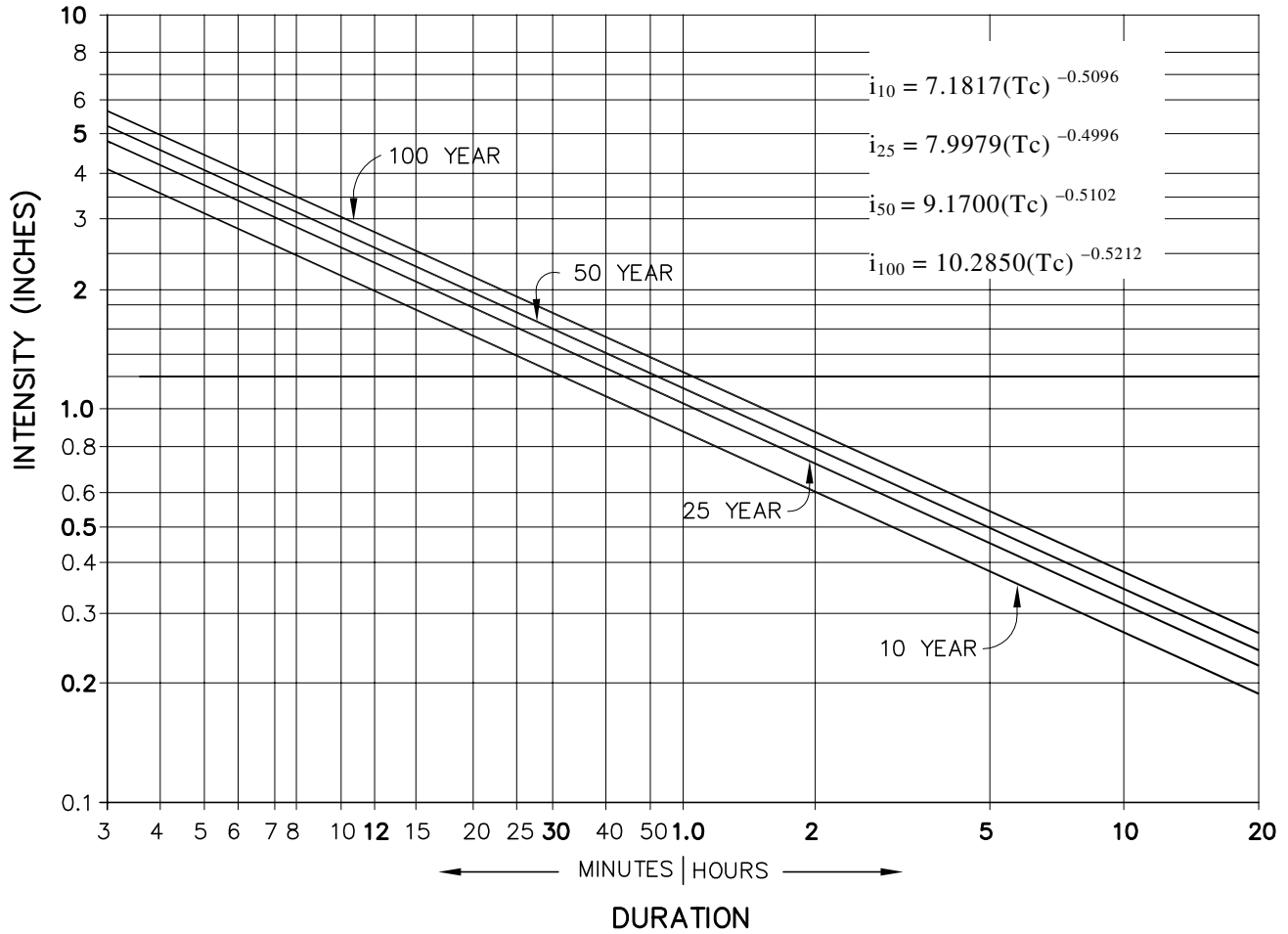

STATION DATA	
LONGITUDE:	123.807
LATITUDE:	39.446
ALTITUDE:	80
YEARS OF DATA:	1940-1985



INTENSITY/DURATION/FREQUENCY CHART FORT BRAGG

MENDOT
STD. NO.
D11D

INTENSITY-DURATION-FREQUENCY CHART

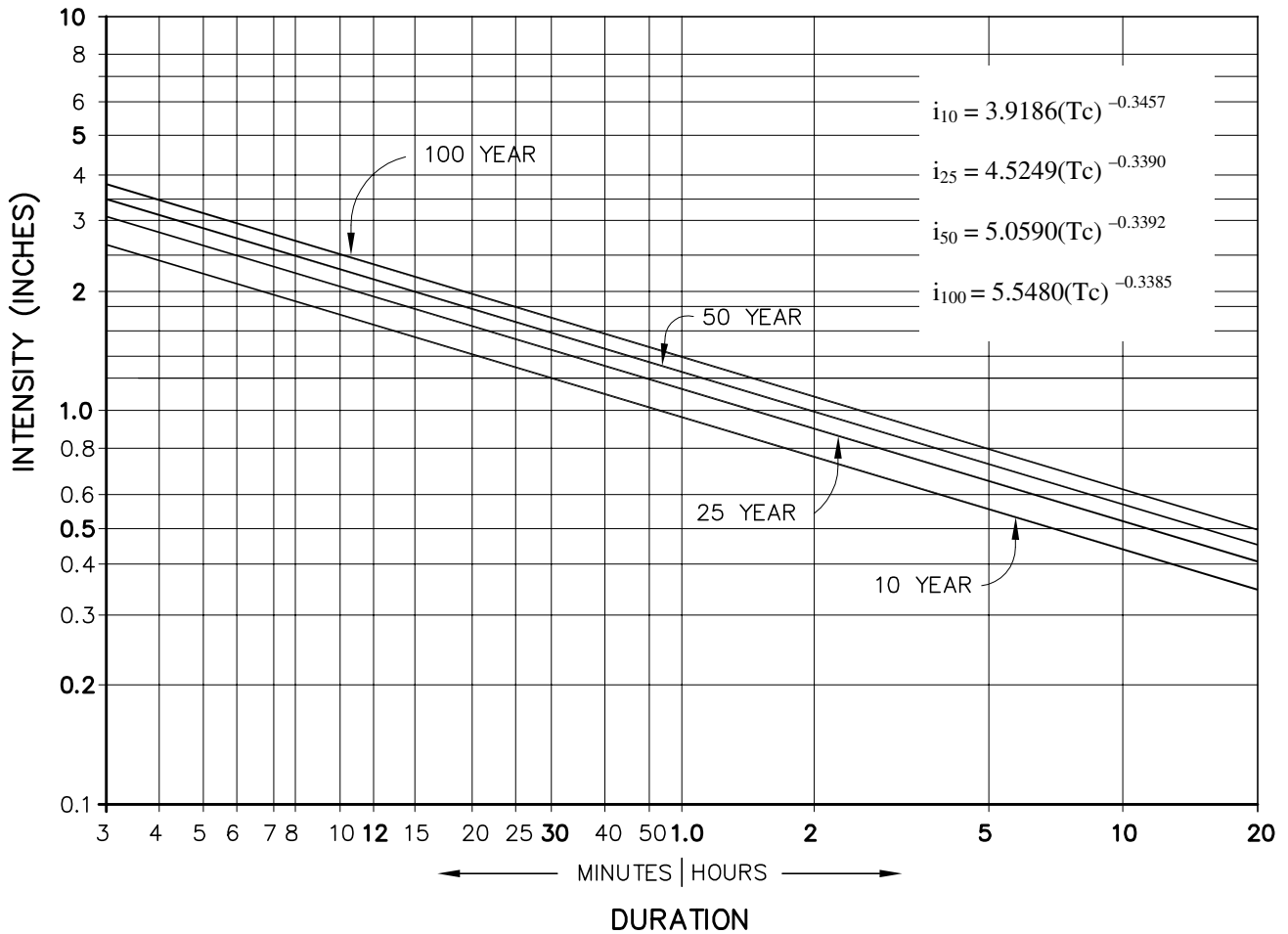

STATION DATA	
LONGITUDE:	123.717
LATITUDE:	39.867
ALTITUDE:	700
YEARS OF DATA:	1972-1986



INTENSITY/DURATION/FREQUENCY CHART LEGGETT

MENDOT
STD. NO.
D11E

INTENSITY-DURATION-FREQUENCY CHART

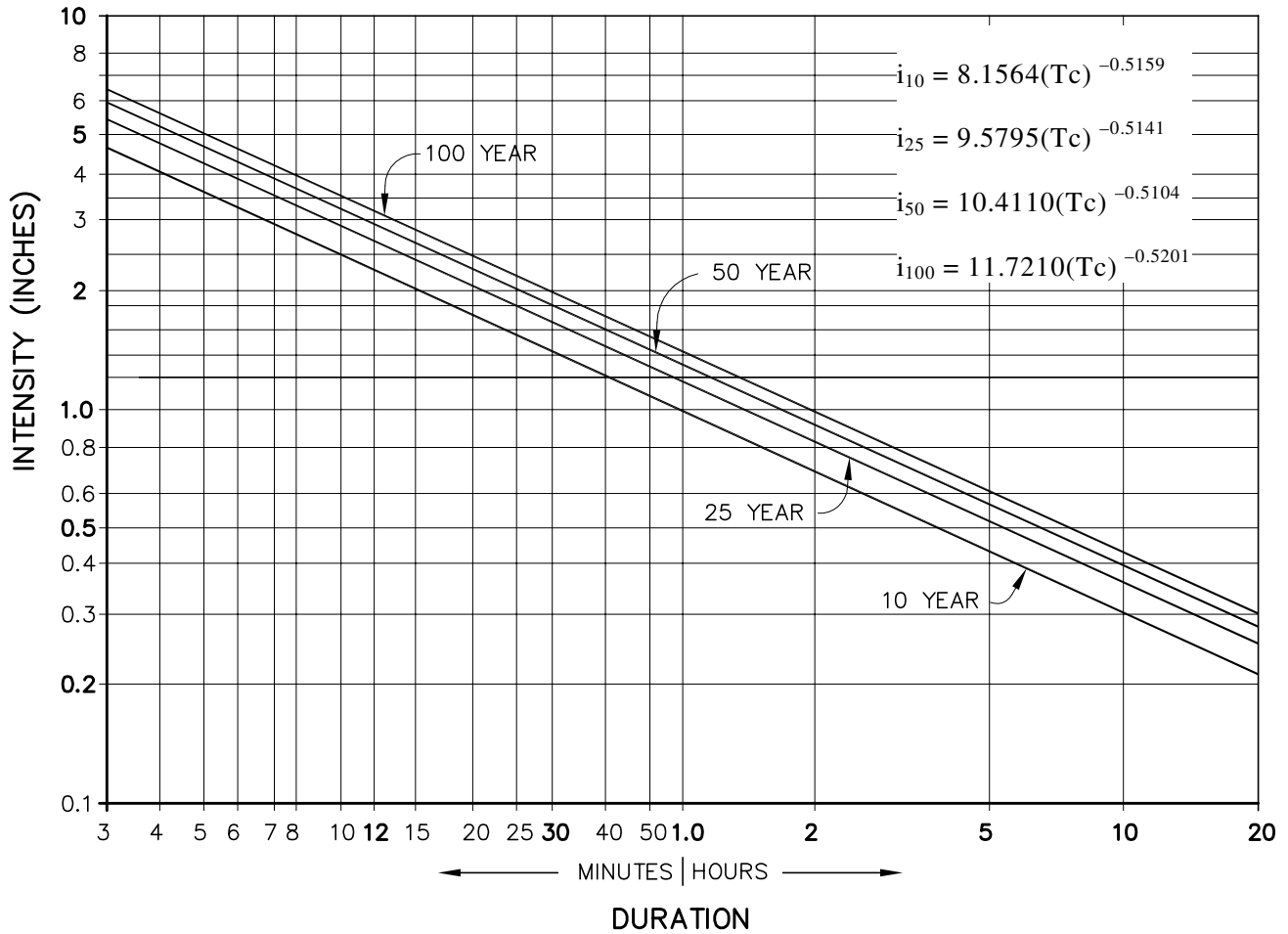

STATION DATA	
LONGITUDE:	123.700
LATITUDE:	38.917
ALTITUDE:	122
YEARS OF DATA:	1940-1986



INTENSITY/DURATION/FREQUENCY CHART POINT ARENA

MENDOT
STD. NO.
D11F

INTENSITY-DURATION-FREQUENCY CHART

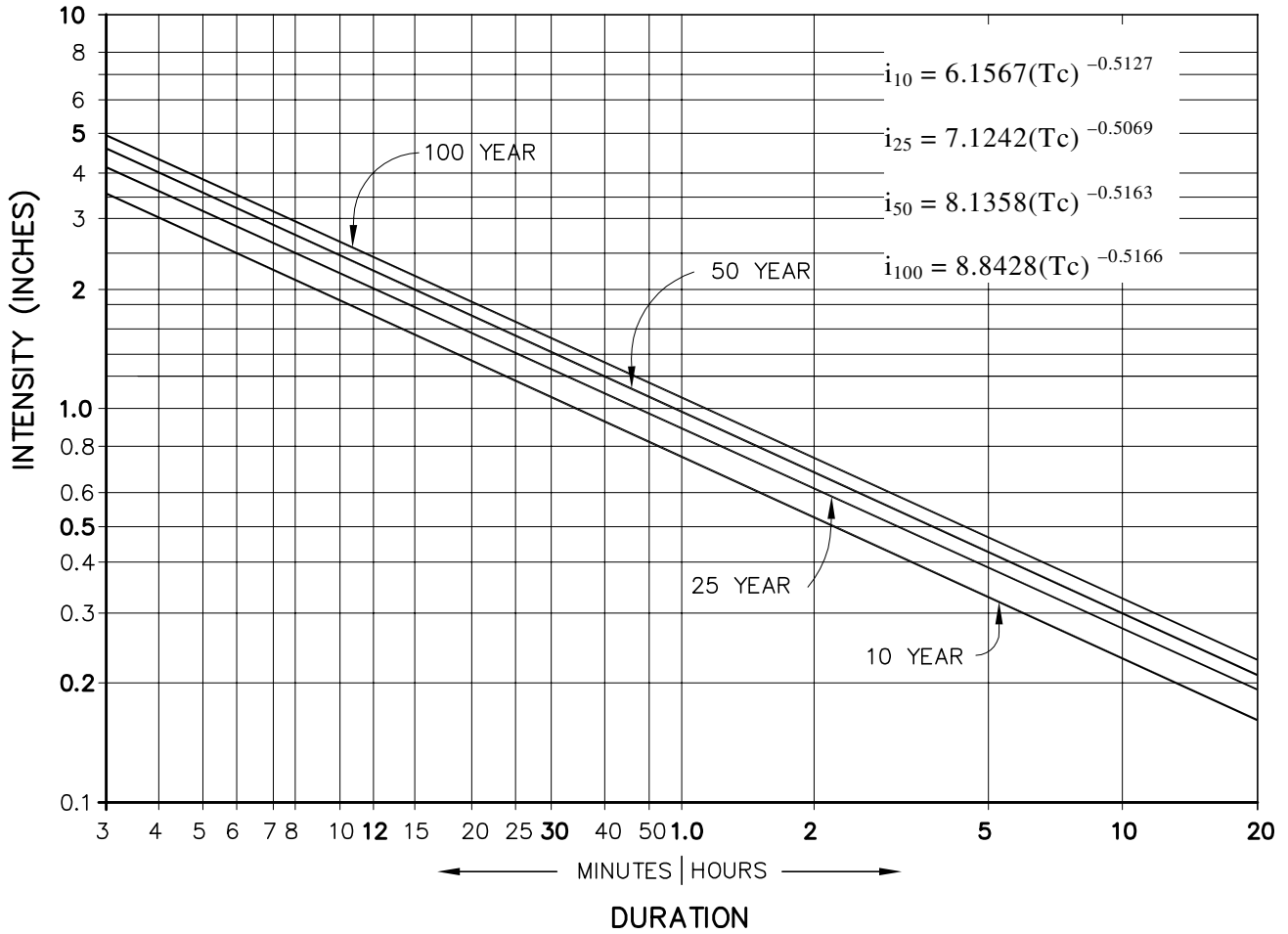

STATION DATA	
LONGITUDE:	123.183
LATITUDE:	39.233
ALTITUDE:	670
YEARS OF DATA:	1972-1986



INTENSITY/DURATION/FREQUENCY CHART UKIAH-LAKE MENDOCINO DAM

MENDOT
STD. NO.
D11G

INTENSITY-DURATION-FREQUENCY CHART

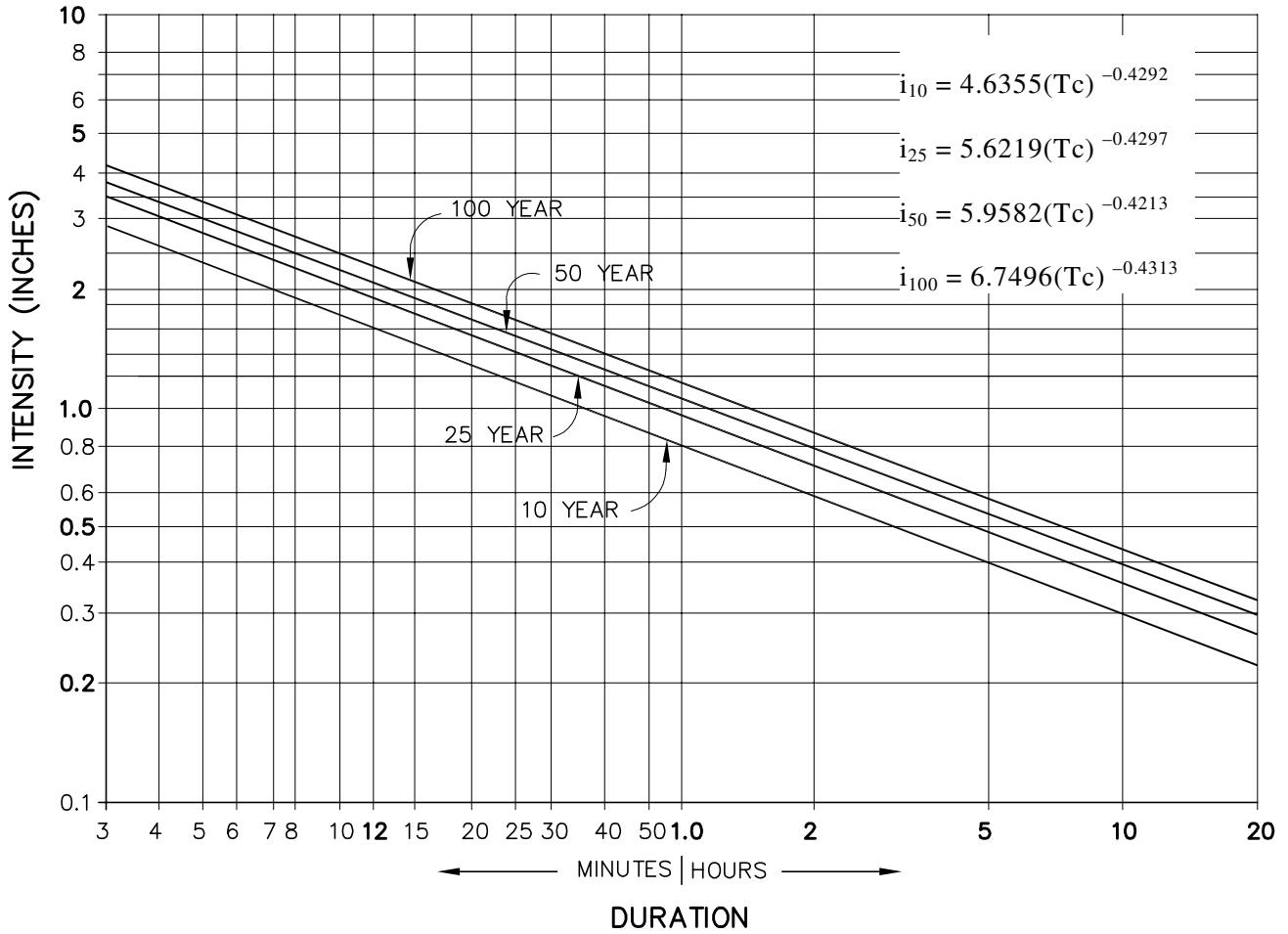

STATION DATA	
LONGITUDE:	123.317
LATITUDE:	39.350
ALTITUDE:	1925
YEARS OF DATA:	1940-1986



INTENSITY/DURATION/FREQUENCY CHART WILLITS HOWARD

MENDOT
STD. NO.
D11H

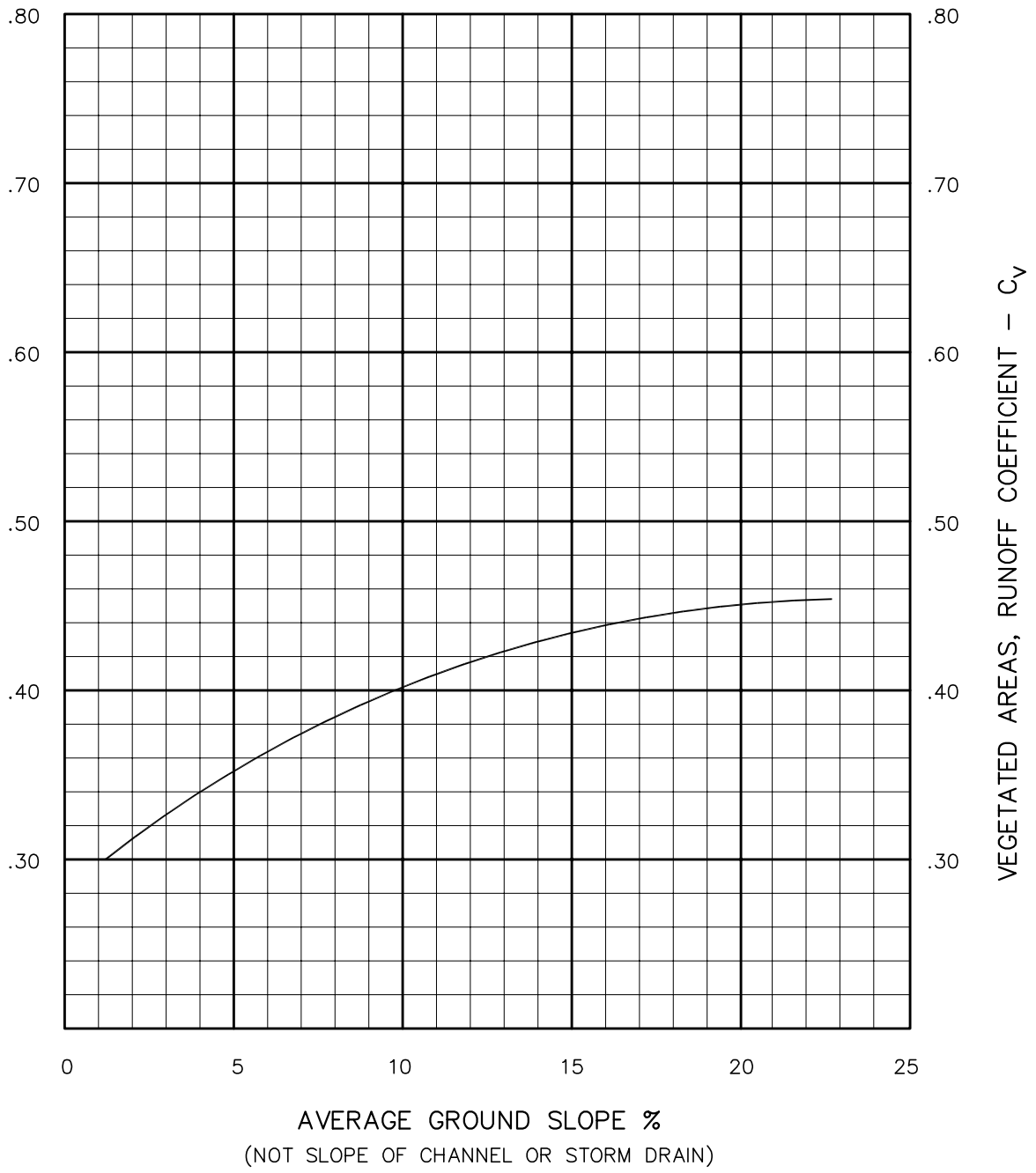

RUNOFF COEFFICIENTS FOR RATIONAL FORMULA, VEGETATED AREAS

MENDOT
STD. NO.
D12

NOTES:

1. IF PIPE INTO OR OUT OF THE CATCH BASIN IS LARGER THAN 24" OR DEPTH 'H' IS GREATER THAN 3', USE MENDOT STD. NO. D21. 'H' IS THE DIFFERENCE IN ELEVATION BETWEEN THE OUTLET PIPE FLOW LINE AND THE NORMAL GUTTER GRADE LINE UNDEPRESSED AT THE CURB FACE.
2. CATCH BASIN BASE MAY BE PRECAST OR CAST IN PLACE, AT CONTRACTOR'S OPTION. IF PRECAST, MEANS SHALL BE PROVIDED FOR ADJUSTMENTS IN FIELD TO MEET FINAL GRADE OF PAVING OR SURFACING. PRECAST BASE SHALL BE SANTA ROSA CAST PRODUCTS MODEL 4A OR APPROVED EQUAL. CAST IN PLACE BASE SHALL BE REINFORCED WITH No. 4 BARS AT 12" EACH WAY (E.W.), 1.5" CLEAR FROM INSIDE FACE OF WALL, AND SHALL BE CLASS 1 CONCRETE (6-SACK MIX).
3. ALL PRECAST MATERIALS SHALL BE GROUTED PER MANUFACTURER'S SPECIFICATIONS.
4. PROVIDE STEPS FOR ALL CATCH BASINS WHERE 'H' IS GREATER THAN 30". SEE CALTRANS STD. PLAN D74C FOR STEP DETAIL.
5. PROVIDE 2" WEEPHOLES AS DIRECTED BY COUNTY DOT INSPECTOR OR GEOTECHNICAL ENGINEER.
6. WALL THICKNESS, 'T', SHALL BE 6".

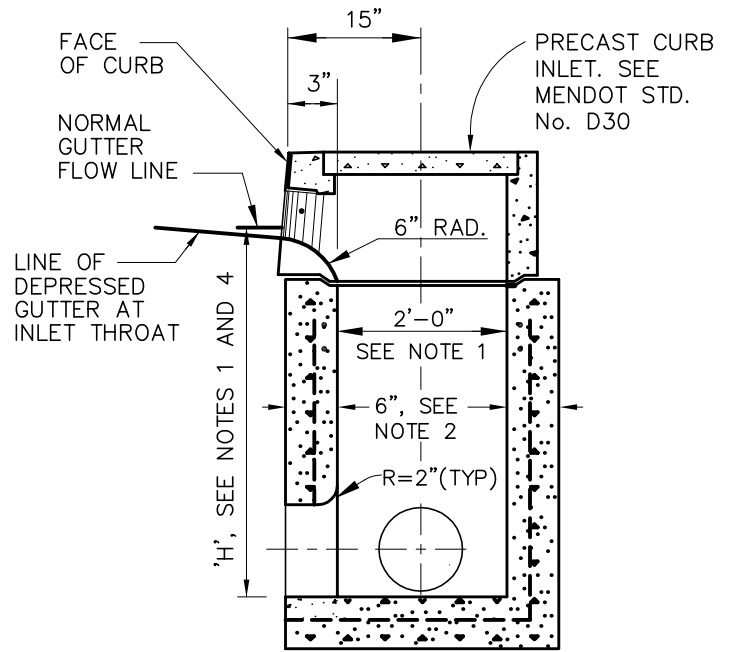

SECTION A-A

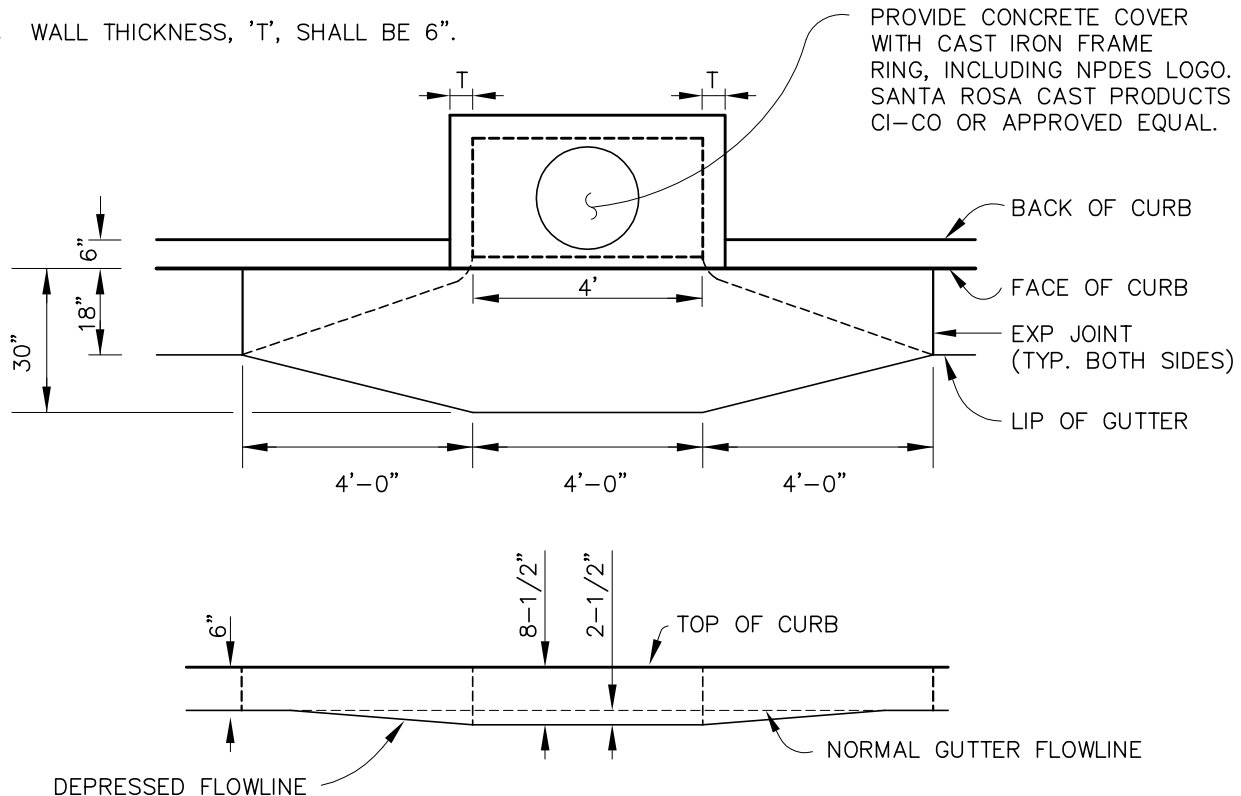

CURB CONFORM



**TYPE "A"
CATCH BASIN**

MENDOT
STD. NO.
D20

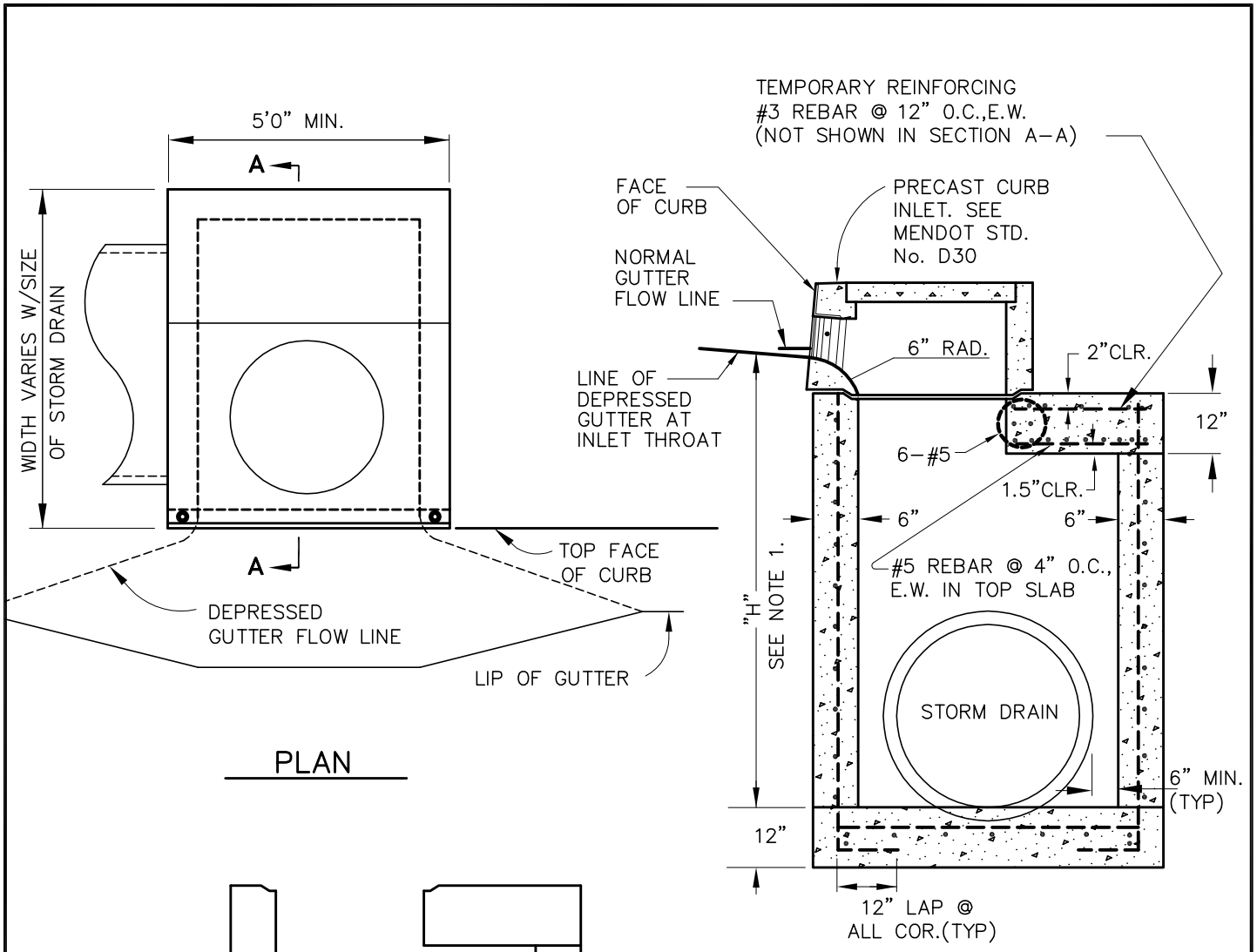

PLAN

SECTION A-A

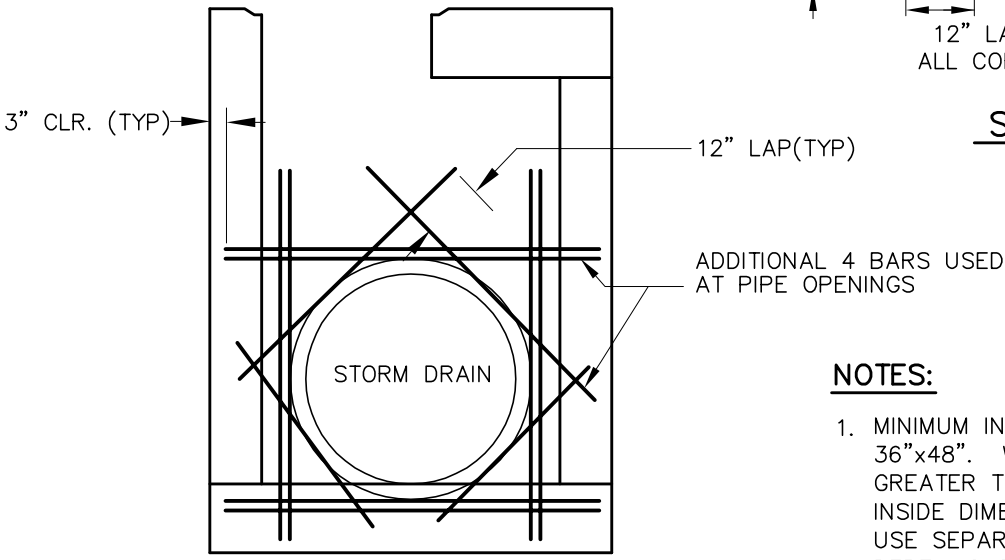

REINFORCING USED @ OPENINGS

NOTES:

1. MINIMUM INSIDE DIMENSION SHALL BE 36"x48". WHERE DEPTH "H" IS GREATER THAN 8' AND UP TO 12', INSIDE DIMENSION SHALL BE 48"x48". USE SEPARATE 60" MANHOLE WHERE DEPTH IS GREATER THAN 12'. PROVIDE STEPS FOR CATCH BASIN WHERE "H" IS GREATER THAN 30". SEE CALTRANS STD. PLAN D74C FOR STEP DETAIL.
2. FOR DETAILS AND NOTES NOT SHOWN, SEE MENDOT STD. D20.



**TYPE "B"
CATCH BASIN**

MENDOT
STD. NO.
D21

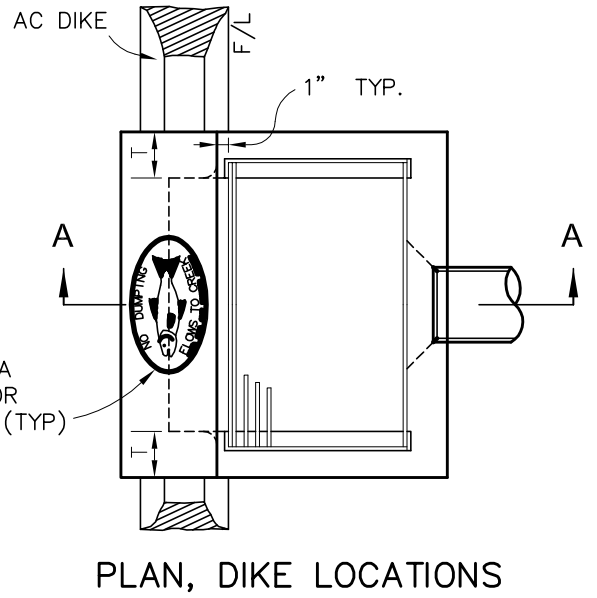
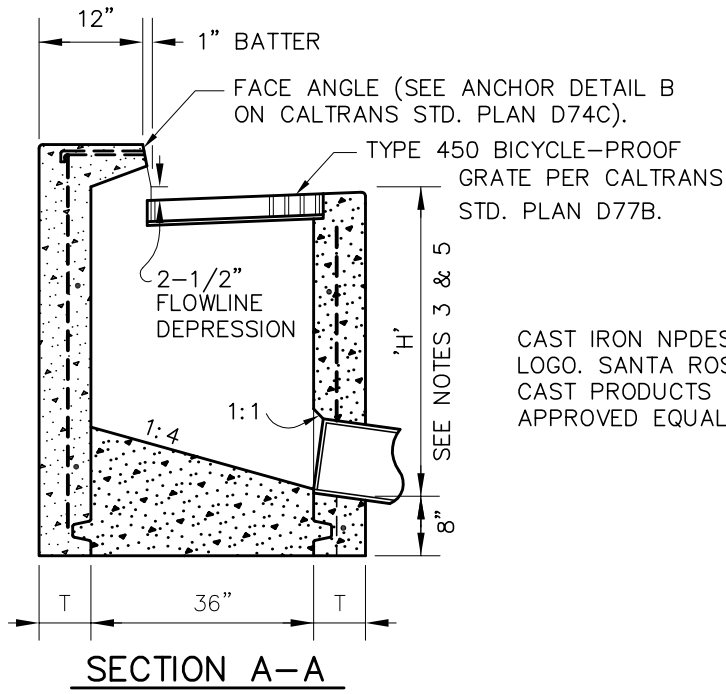

CAST IRON NPDES LOGO. SANTA ROSA CAST PRODUCTS OR APPROVED EQUAL (TYP)

NOTES:

1. SEE MENDOT STD D20 FOR DETAILS AND NOTES NOT SHOWN.
2. CATCH BASIN INLET MAY BE PRECAST OR CAST IN PLACE, AT CONTRACTOR'S OPTION. PRECAST INLET SHALL BE SANTA ROSA CAST PRODUCTS MODEL GOL, OR APPROVED EQUAL. FOR DIKE LOCATIONS, PRECAST INLET SHALL BE SANTA ROSA CAST PRODUCTS MODEL G2, OR APPROVED EQUAL.
3. CATCH BASIN INLET MAY BE PRECAST OR CAST IN PLACE, AT CONTRACTOR'S OPTION. IF PRECAST, MEANS SHALL BE PROVIDED FOR ADJUSTMENTS IN THE FIELD TO MEET FINAL GRADE OF PAVING OR SURFACING. PRECAST BASE SHALL BE SANTA ROSA CAST PRODUCTS OR APPROVED EQUAL. CAST IN PLACE BASE SHALL BE REINFORCED WITH No. 4 BARS AT 12" EACH WAY (E.W.), 1.5" CLEAR FROM INSIDE FACE OF WALL, AND SHALL BE CLASS 1 CONCRETE (6 SACK MIX). PROVIDE 48" MANHOLE BASE WHERE 'H' IS GREATER THAN 8' AND UP TO 12' USING SRCP REDUCER SLAB 48MH-IM OR APPROVED EQUAL. PROVIDE SEPARATE 60" MANHOLE WHERE DEPTH IS GREATER THAN 12'. 'H' IS THE DIFFERENCE IN ELEVATION BETWEEN THE OUTLET PIPE FLOW LINE AND THE NORMAL GUTTER GRADE LINE UNDEPRESSED AT THE CURB FACE.
4. ALL PRECAST MATERIALS SHALL BE GROUTED PER MANUFACTURER'S SPECIFICATIONS.
5. PROVIDE STEPS FOR CATCH BASINS WHERE 'H' IS GREATER THAN 30". SEE CALTRANS STD. PLAN D74C FOR STEP DETAIL.
6. PROVIDE 2" WEEPHOLES AS DIRECTED BY COUNTY DOT INSPECTOR OR GEOTECHNICAL ENGINEER.
7. WALL THICKNESS, "T", SHALL BE 6" FOR DEPTHS UP TO 8' AND SHALL BE 8" FOR DEPTHS GREATER THAN 8'.

EXPANSION JOINT, TYP. BOTH SIDES.

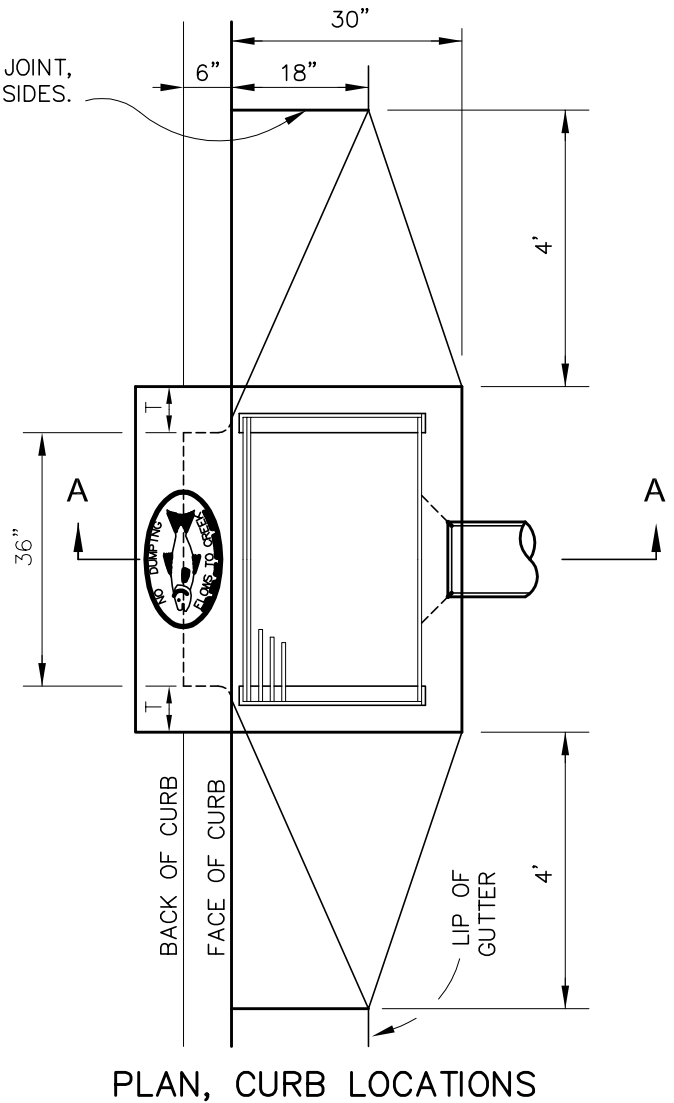

**TYPE "C"
CATCH BASIN**

MENDOT
STD. NO.
D22

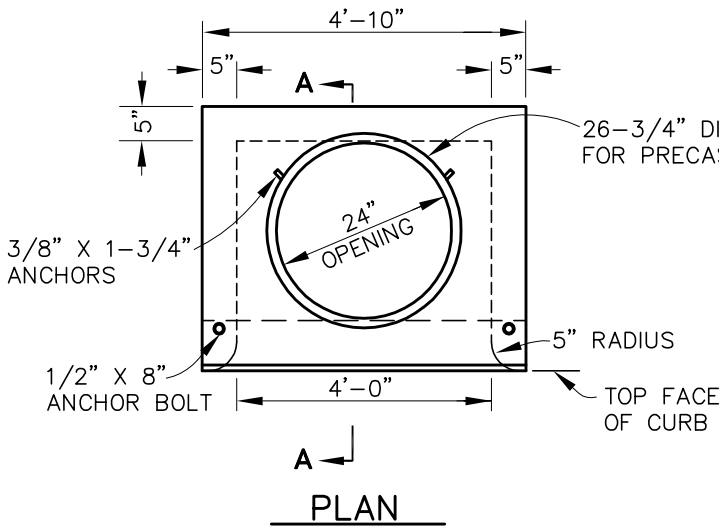

PLAN

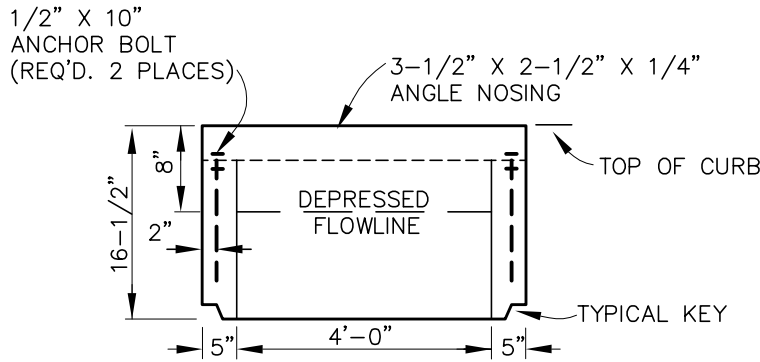

ELEVATION

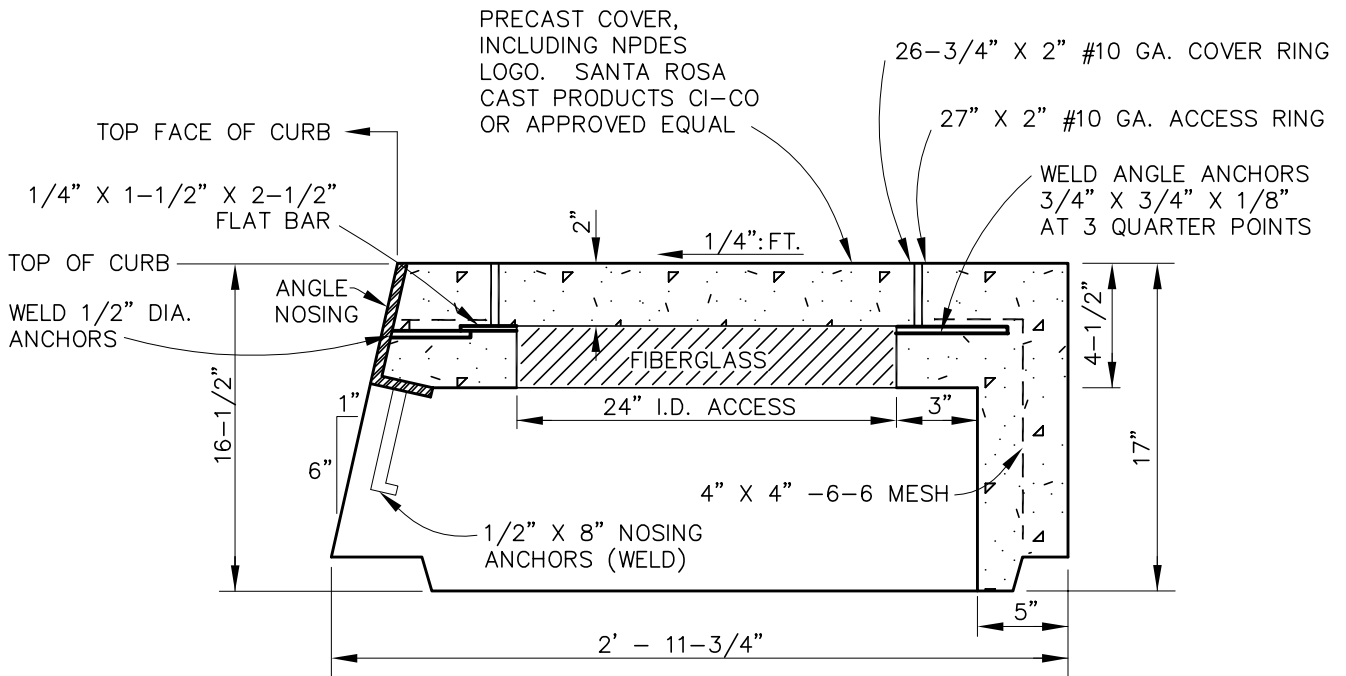

SECTION A-A

NOTES:

1. ALL METAL PARTS SHALL BE HOT DIPPED GALVANIZED AFTER FABRICATION PER ASTM A123.
2. CONCRETE SHALL TEST 3000 PSI AT 28 DAYS.
3. ALL REINFORCING SHALL BE 4" X 4" - 6-6 MESH.
4. WEIGHT OF UNIT COMPLETE = 1500± LBS. COVER ONLY = 100± LBS.
5. 3/4" GALVANIZED STEEL GUARD ROD FOR OPENINGS IN EXCESS OF 9".
6. BASE MAY BE PRECAST OR CAST IN PLACE TO SUIT.
7. PRECAST UNIT SHALL BE SANTA ROSA PRECAST 4AC OR APPROVED EQUAL.



PRECAST CURB INLET

MENDOT
STD. NO.
D30

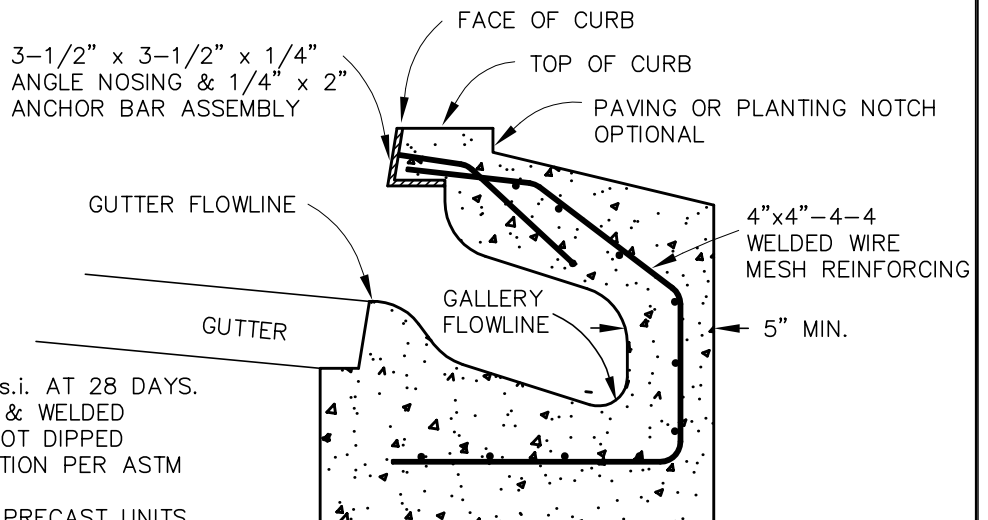
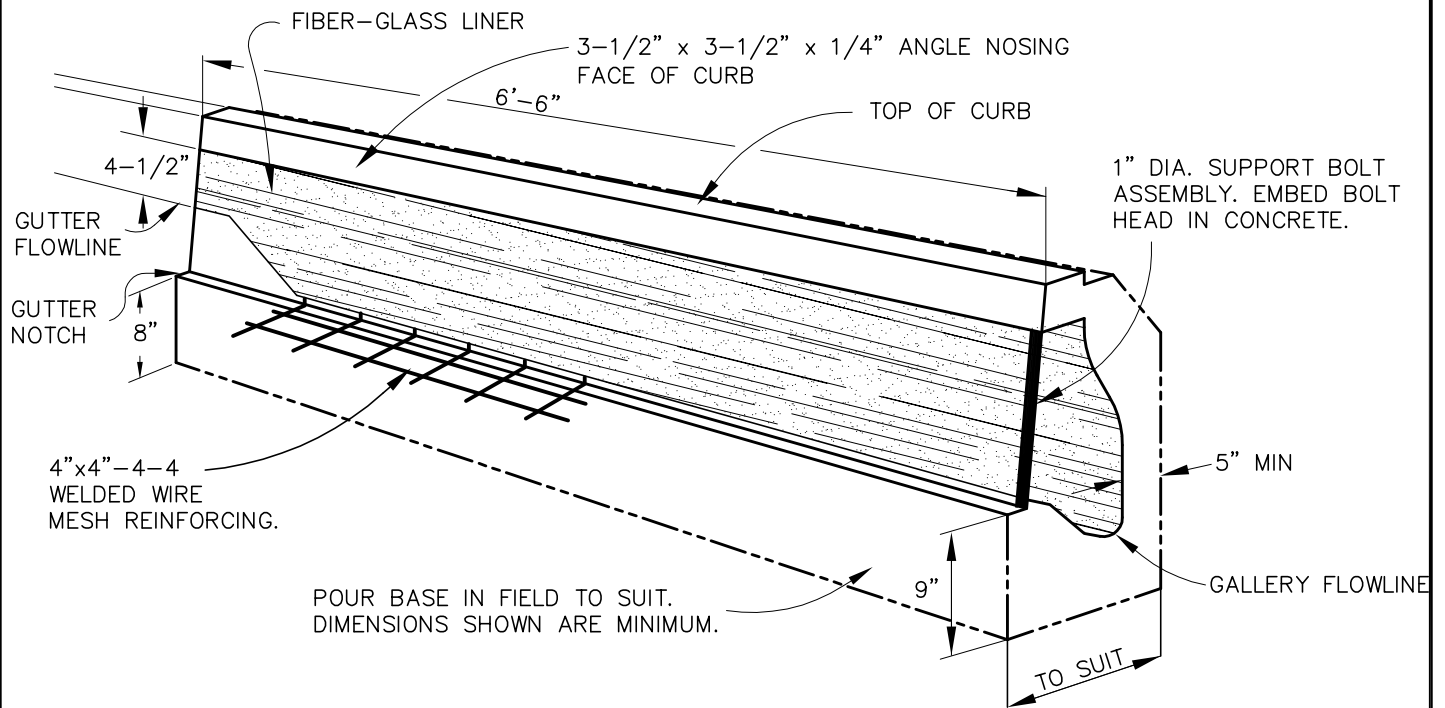

NOTES:

1. CONCRETE SHALL BE 3000p.s.i. AT 28 DAYS.
2. NOSING ASSEMBLY (ANGLED & WELDED ANCHOR BARS) SHALL BE HOT DIPPED GALVANIZED AFTER FABRICATION PER ASTM SPEC. A123-59.
3. EITHER CAST-IN-PLACE OR PRECAST UNITS ARE ACCEPTABLE.

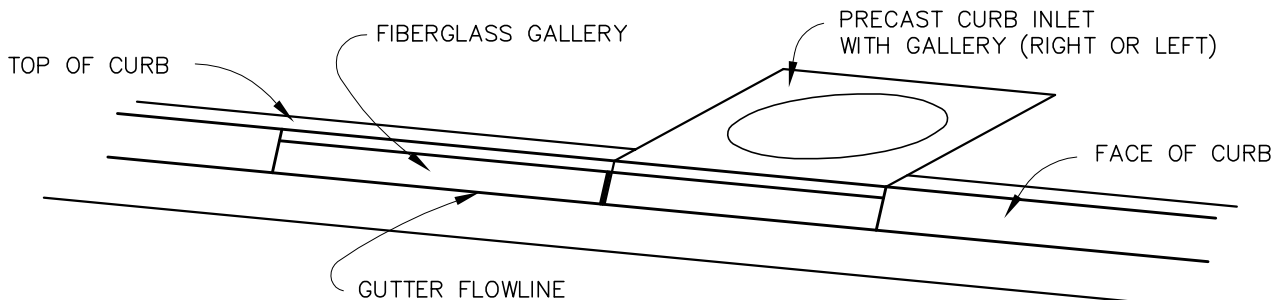

GALLERY INLET

MENDOT
STD. NO.
D31

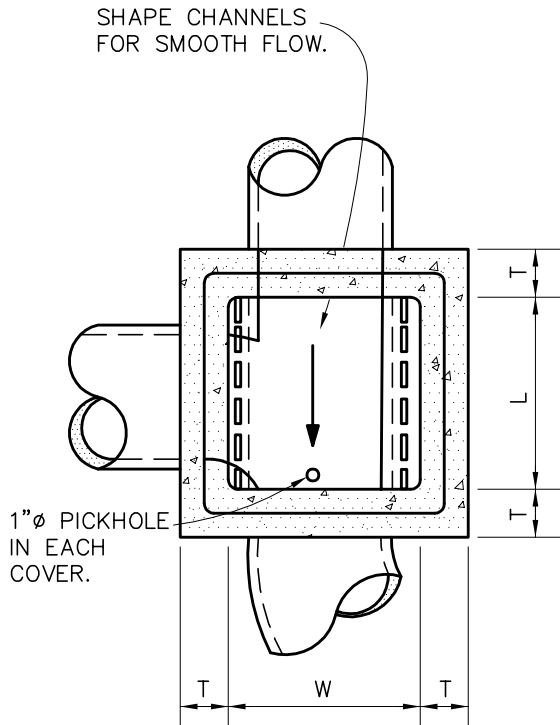

PLAN SECTION

2 1/2" x 1 1/2" x 1/4" L,
WELD TO CHECKPLATE

IF USED AS V-DITCH
DROP INLET, FORM SIDES
TO FIT STD. DITCH. INSTALL
GALV. BAR ACROSS OPENING
AND 2 1/2" x 1 1/2" x 1/4"
AT TOP. INLET FROM EARTH
DITCH MAY BE PER SANTA
ROSA PRE CAST PRODUCTS
TYPICAL SIDE OPENING.

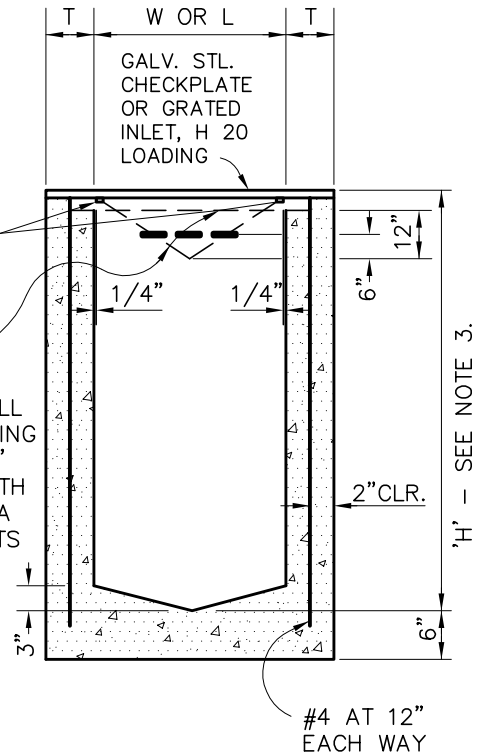

PROFILE SECTION

DEPTH	L	W	T	COVER(S)
3' OR LESS	24"	24"	6"	1 - 36"x 36"
OVER 3' TO 8'	36"	36"	6"	2 - 24"x 48"
OVER 8' TO 12'	SEE NOTE 3		8"	2 - 30"x 48"
OVER 12'	CUSTOM STRUCTURE			

NOTE:

1. SEE MENDOT STD D20 FOR GENERAL NOTES, REINFORCING, AND STEP REQUIREMENTS.
2. DROP INLET MAY BE PRECAST OR CAST IN PLACE, AT CONTRACTOR'S OPTION. PRECAST INLET SHALL BE SANTA ROSA CAST PRODUCTS (SRCP) MODEL 2K, 1M, OR 3M OR APPROVED EQUAL.
3. PROVIDE 40" MANHOLE BASE WHERE 'H' IS GREATER THAN 8' AND LESS THAN OR EQUAL TO 12', USE SRCP REDUCER SLAB 48MH-1M OR APPROVED EQUAL.



DROP INLET AND TURNING STRUCTURE

MENDOT
STD. NO.
D32

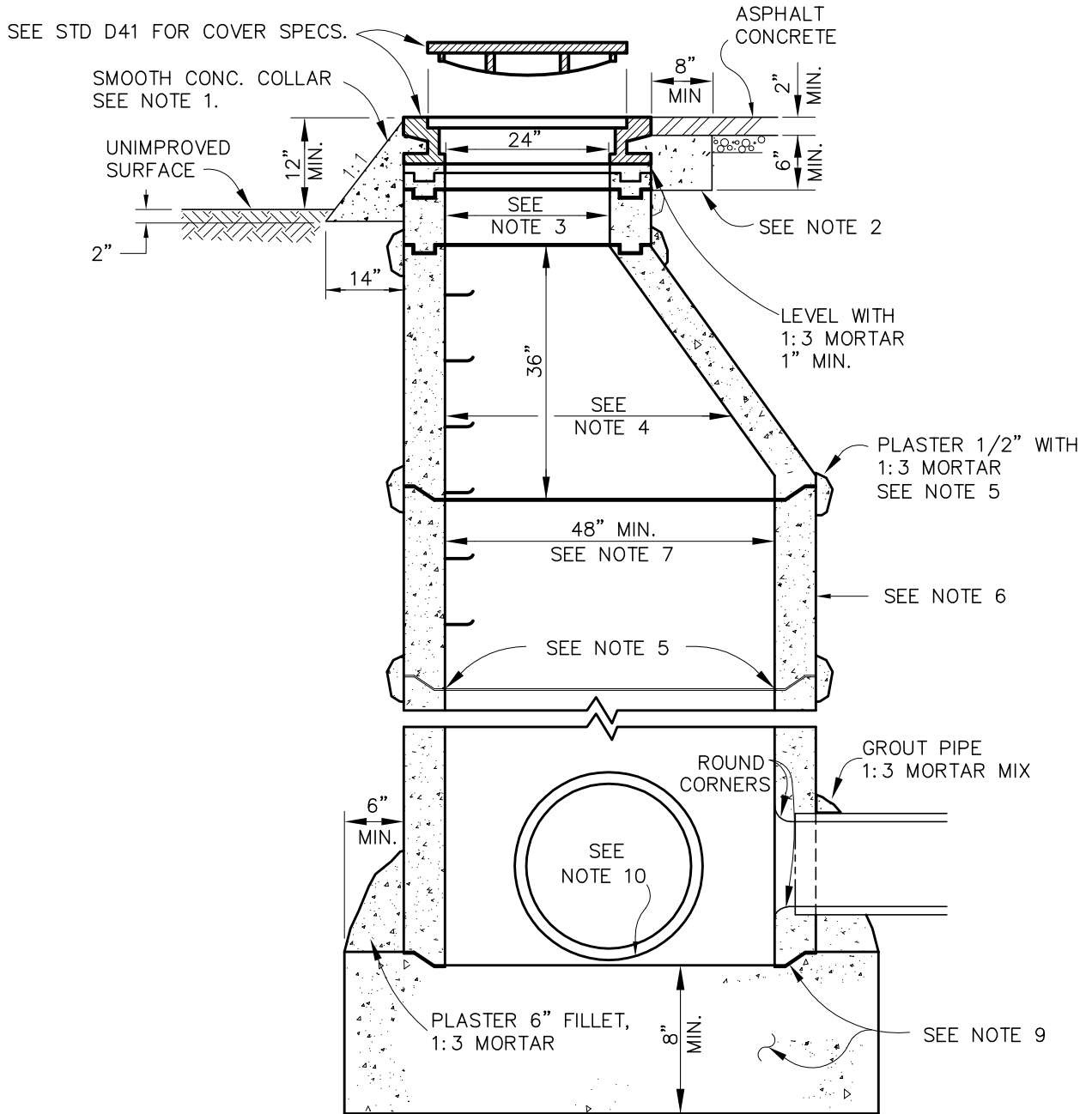

NOTE: SEE MANHOLE NOTES ON STANDARD D40B



STORM DRAIN MANHOLE

MENDOT
STD. NO.
D40A

NOTES:

1. WHEN MANHOLES ARE INSTALLED IN UNIMPROVED AREAS, THE TOP OF THE COVER SHALL BE A MINIMUM OF 1 FOOT ABOVE ADJACENT GRADE AND CONCRETE COLLAR SHALL BE PROVIDED. CONCRETE COLLAR SHALL BE CLASS 1 CONCRETE (6-SACK MIX). SEE DETAIL.
2. WHEN MANHOLES ARE INSTALLED IN PAVED AREAS, CONCRETE COLLAR SHALL BE PROVIDED. SEE DETAIL.
3. PROVIDE A MINIMUM OF ONE 3" AND ONE 6" GRADE ADJUSTMENT RING AT TOP OF MANHOLE. MAXIMUM HEIGHT OF GRADE ADJUSTMENT RINGS SHALL NOT EXCEED 20".
4. CONE SECTION SHALL BE ECCENTRIC, WITH STEPS ON THE VERTICAL SIDE. STEPS SHALL BE PER CALTRANS STD. PLAN D74C. WHERE DEPTH IS NOT SUFFICIENT TO PROVIDE CONE SECTION, REDUCER SLAB PER MENDOT STD. D42 SHALL BE USED.
5. ALL JOINTS SHALL BE SEALED WITH RAM-NEK JOINT COMPOUND, 1:3 MORTAR MIX, OR APPROVED EQUAL. WET BOTH TONGUE AND RING BEFORE APPLYING MORTAR AND SETTING RING. WIPE INSIDE EDGE OF JOINTS SMOOTH AND PROVIDE POINTED JOINT. PLASTER OUTSIDE OF JOINT WITH 1/2" LAYER OF MORTAR.
6. PRECAST MANHOLE MATERIAL SHALL BE MANUFACTURED TO ASTM SPECIFICATION C-478. ALL SECTIONS OF MANHOLE SHALL BE IDENTICAL MAKE AND MANUFACTURER. PRECAST MANHOLE SHALL BE SANTA ROSA PRECAST MODEL M48E OR APPROVED EQUAL.
7. DEPTH SHALL BE MEASURED FROM RIM TO FLOWLINE OF OUTLET PIPE. MANHOLES OVER 7 FEET IN DEPTH, OR WITH A PIPE GREATER THAN 36" INSIDE DIAMETER, SHALL BE 5 FEET INSIDE DIAMETER.
8. MENDOT STD. NO. D40 SHALL NOT BE USED FOR MANHOLES LESS THAN 3 FEET IN DEPTH, PIPES GREATER THAN 60" INSIDE DIAMETER, OR FOR MANHOLES WITH MORE THAN 3 PIPE CONNECTIONS.
9. BASE SHALL BE CAST IN PLACE TO FULL THICKNESS SHOWN. BASE SHALL BE CONSTRUCTED OF CLASS 1 CONCRETE (6-SACK MIX) AND SHALL BE PLACED AGAINST UNDISTURBED EARTH. JOINT BETWEEN BASE AND FIRST WALL SECTION SHALL BE FORMED BY SETTING WALL SECTION ON FRESH CONCRETE OR BY USING TONGUE & GROOVE IMPRESSION RING.
10. CONSTRUCT FLOW CHANNELS TO MATCH PIPE SHAPE USING STEEL TROWEL. ELEVATION CHANGES THROUGH MANHOLE SHALL BE A STRAIGHT GRADE WITH NO ABRUPT CHANGES. DIRECTIONAL CHANGES SHALL BE MADE WITH SMOOTH CURVES.

NOTE: NOTES REFER TO MENDOT STD. D40A.



**STORM DRAIN MANHOLE
NOTES**

MENDOT
STD. NO.
D40B

SCALE: NONE | DESIGN: RCW | DRAWN: LMM | OCT. 2000

PAGE: A-67

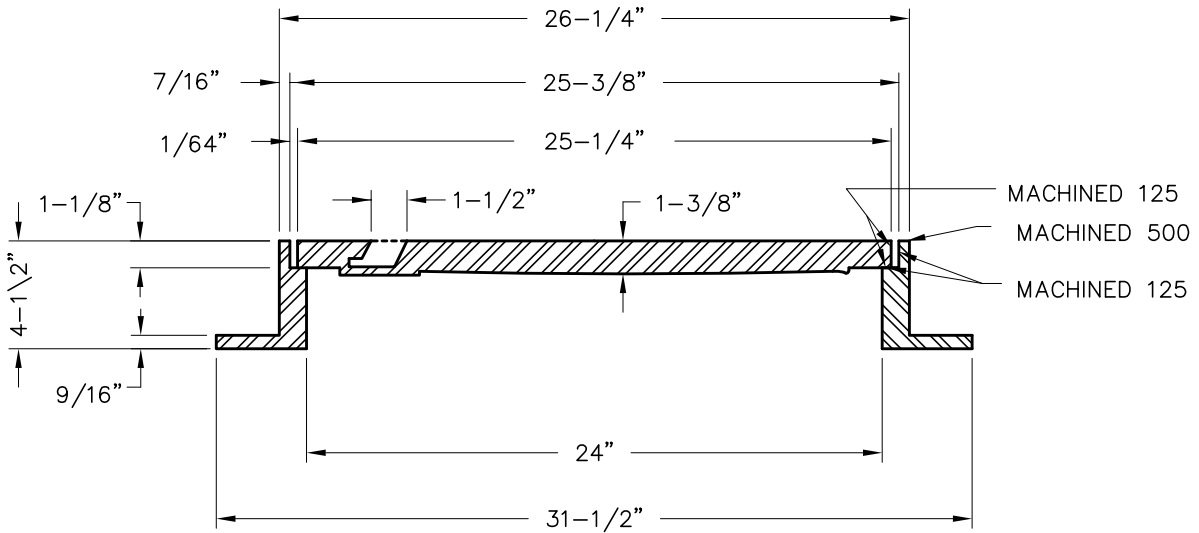
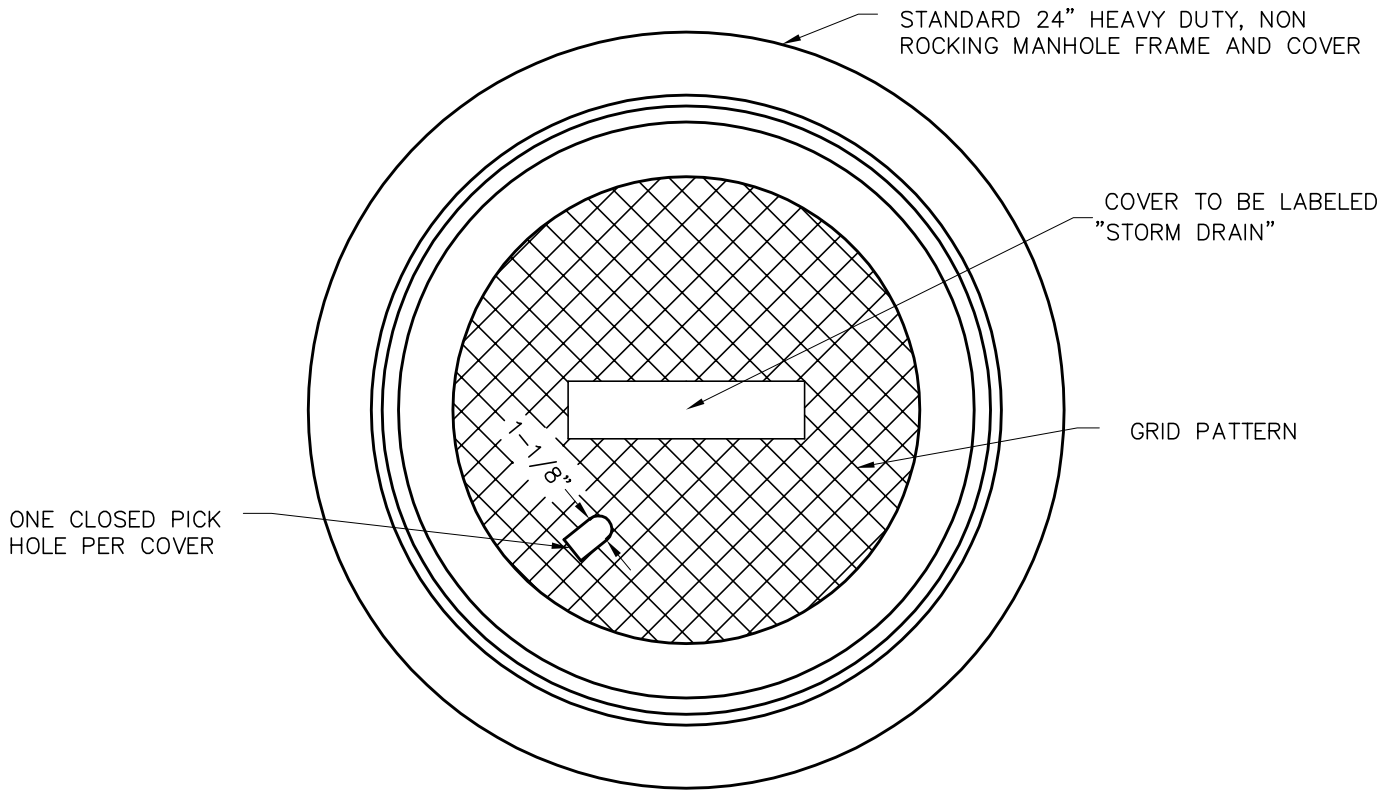

NOTES:

1. ALL CASTINGS SHALL BE DIPPED IN APPROVED ASPHALT PAINT.
2. ALL MATERIAL USED IN MANUFACTURING SHALL CONFORM TO A.S.T.M. DESIGNATION 48-30, OR TO UNITED STATES GOVERNMENT SPECIFICATIONS QQI-652B.
3. MINIMUM WEIGHT COMPONENTS: COVER - 130 POUNDS
FRAME - 135 POUNDS
4. CAST IRON FRAME AND COVER SHALL BE MACHINE FITTED AND PAINTED WITH BITUMINOUS PAINT. SOUTHBAY FOUNDRY SBF1900 OR APPROVED EQUAL.



**STORM DRAIN MANHOLE
FRAME AND COVER**

MENDOT
STD. NO.
D41

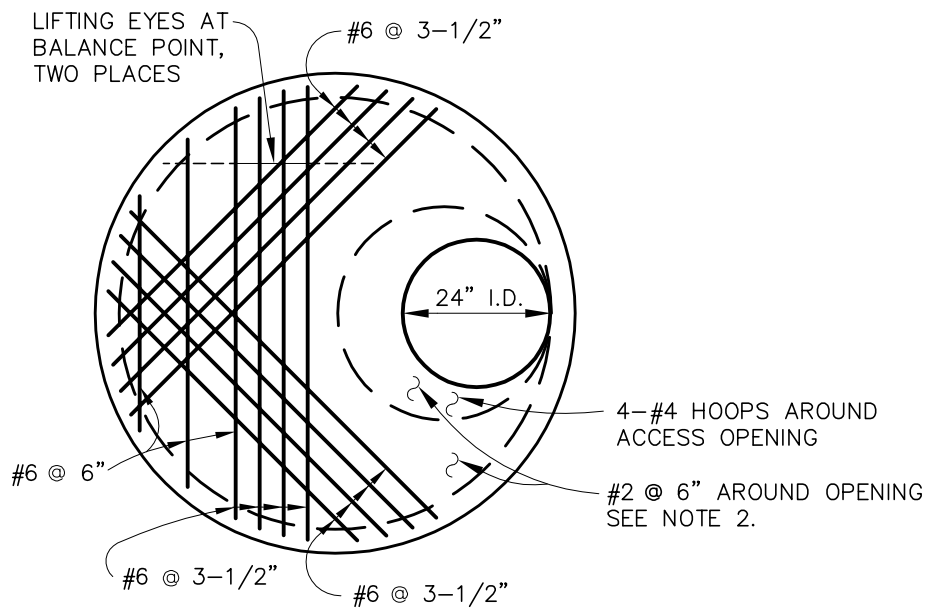

SLAB PLAN

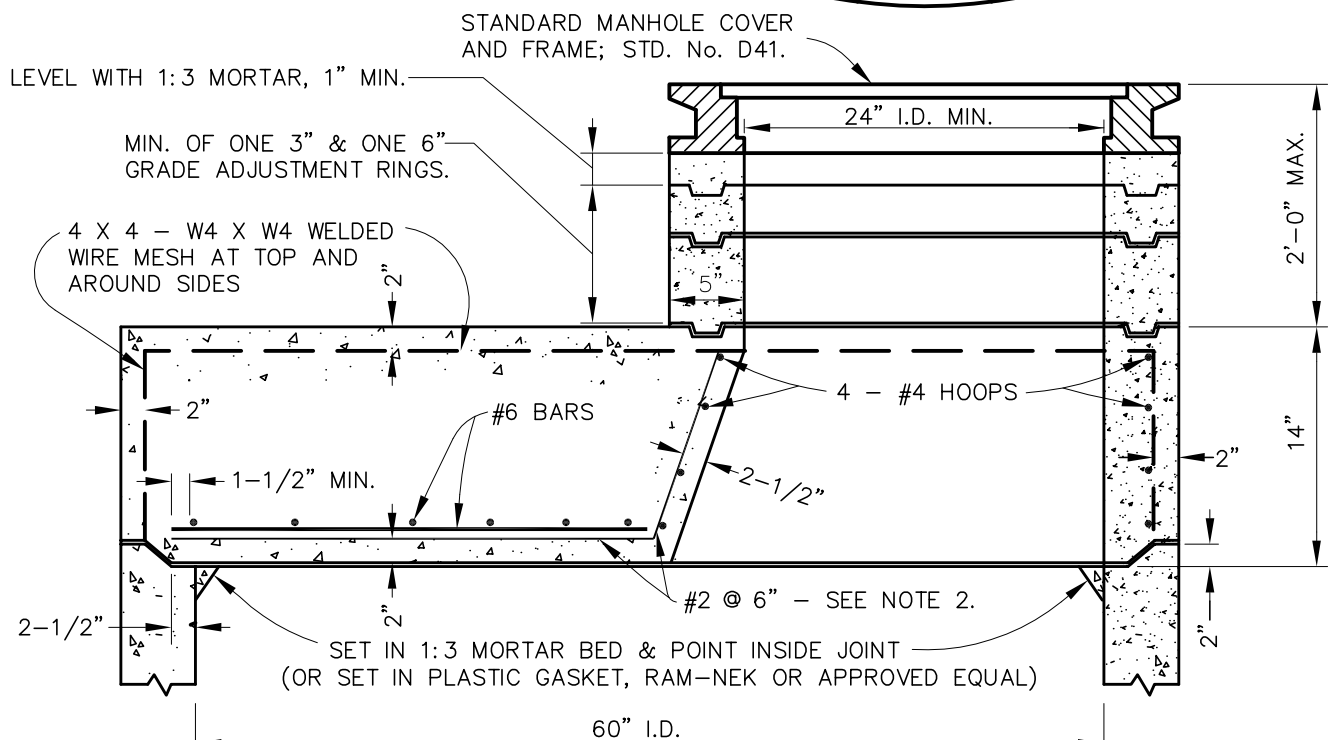
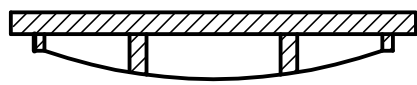

NOTES:

1. FOR DETAILS OF BASE AND BARREL SECTIONS, SEE COUNTY STD No. D40A AND D40B.
2. #2 BARS BENT UP AND SPACED 6" O.C. AROUND 24" OPENING. HORIZONTAL LEGS TO FAN OUT EQUALLY SPACED, TO 2-1/2" CLEAR AT EDGE OF SLAB.
3. REDUCER SLAB MAY BE PRECAST OR CAST IN PLACE, AT CONTRACTOR'S OPTION. PRECAST SLAB SHALL BE CERTIFIED BY THE MANUFACTURER FOR H20 HIGHWAY LOADING AND SHALL BE SANTA ROSA PRECAST M60-24E OR APPROVED EQUAL. FOR 48" DIAMETER MANHOLES, USE SANTA ROSA PRECAST M48-24E OR APPROVED EQUAL.



**STORM DRAIN MANHOLE
PRECAST CONCRETE REDUCER SLAB**

MENDOT
STD. NO.
D42

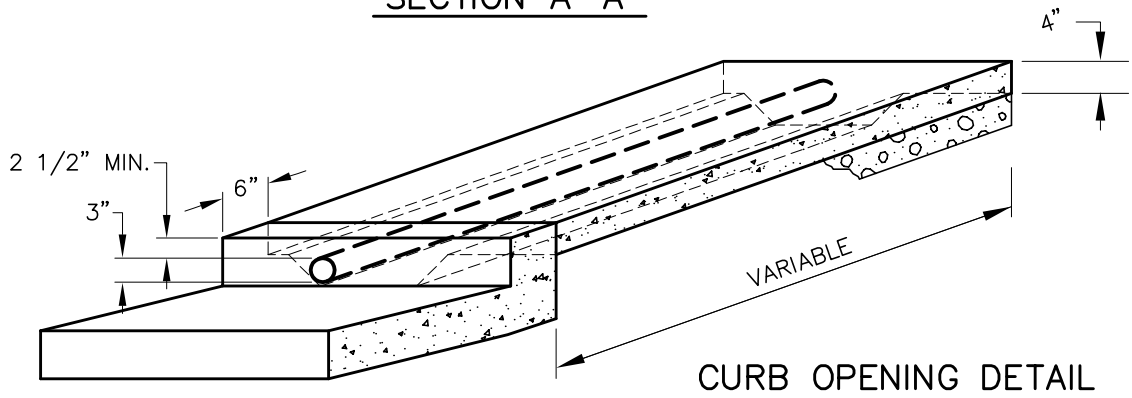
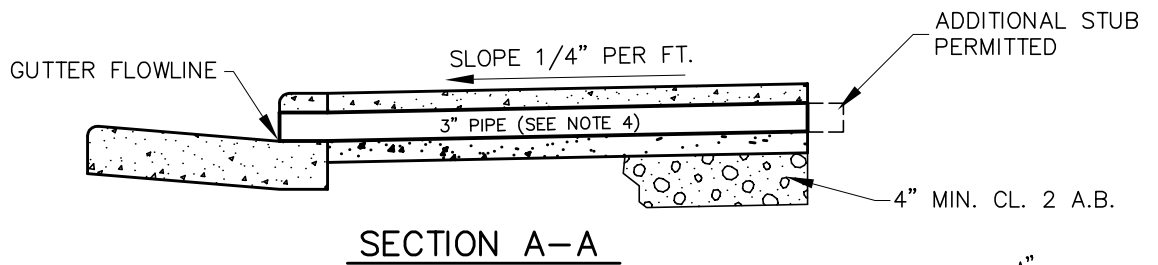
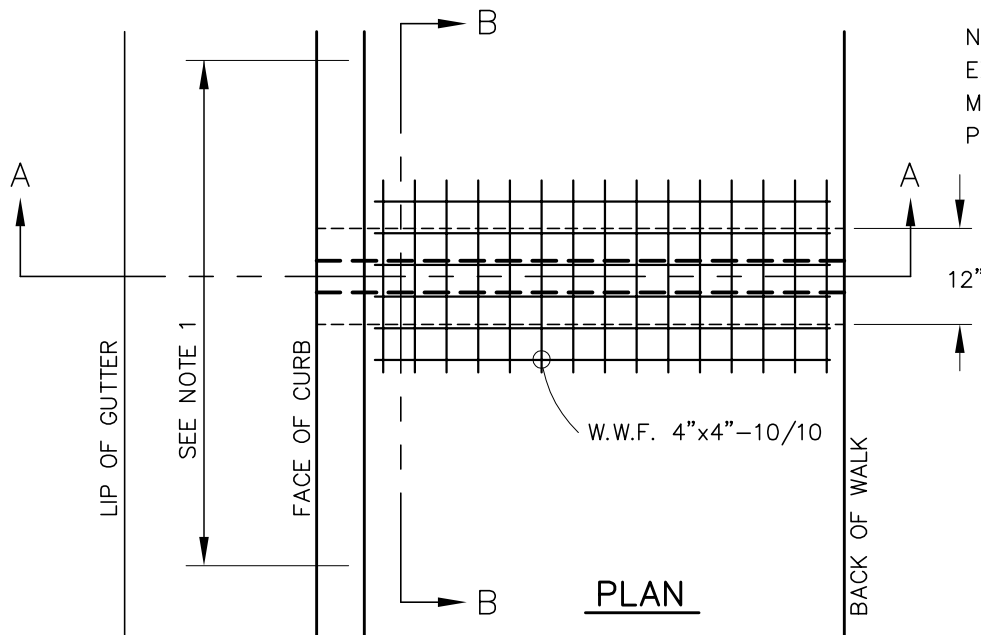

NOTES:

1. WIRE MESH SHALL BE 2' WIDE. LENGTH SHALL EQUAL SIDEWALK WIDTH MINUS 4". IF SIDEWALK EXISTING, SEE NOTE ABOVE.
2. ON SITE DRAINAGE AND LOCATION OF CURB OUTLETS SHALL BE BY THE OWNER TO THE SATISFACTION OF THE COUNTY.
3. DRAIN PIPE SHALL BE INSTALLED SO THAT TOP OF PIPE IS 2 1/2" MIN. BELOW FINISH GRADE AT BACK OF SIDEWALK
4. SIDEWALK DRAIN TO BE 3" SCH 40 HEAVY WALL RIGID POLYVINYL CHLORIDE PIPE OR APPROVED SUBSTITUTE.

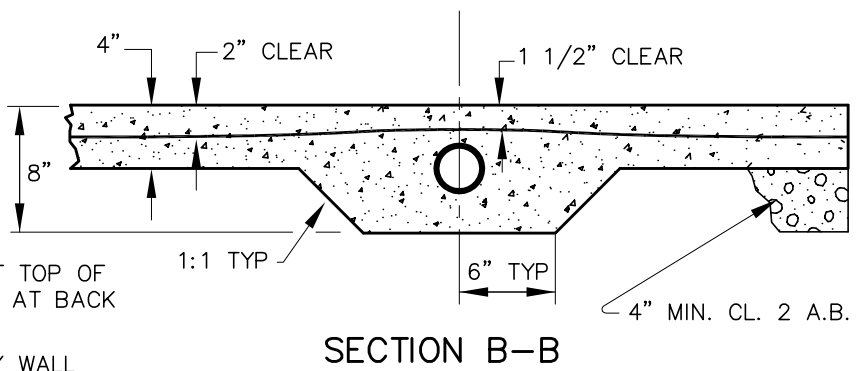

**CURB OUTLET
TYPE "A"**

MENDOT
STD. NO.
D50

SCALE: NONE

DRAWN: LMM

APPVD: RCW

OCT. 2000

PAGE: A-70

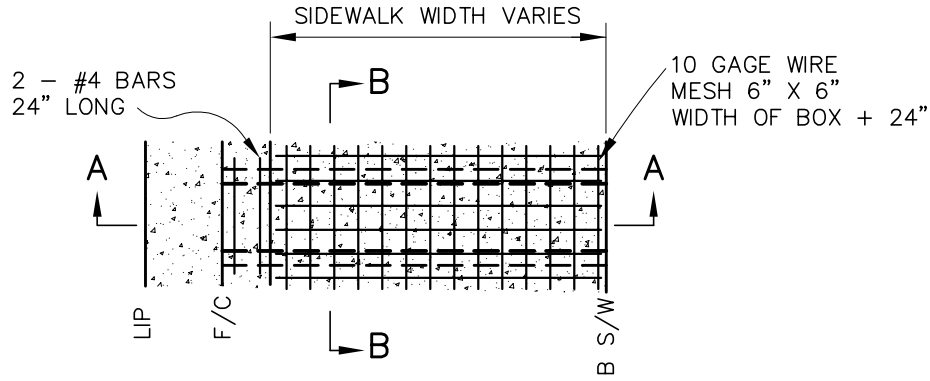

PLAN

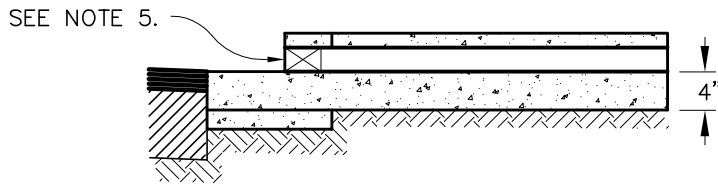

SECTION A-A

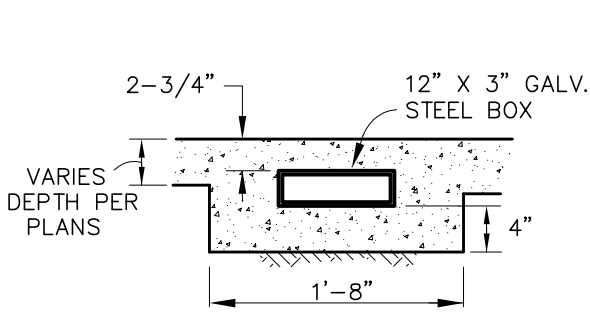

SECTION B-B

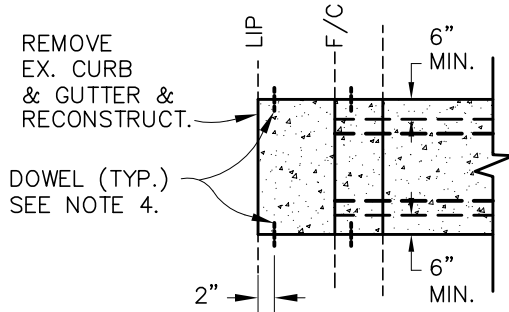

EX. SIDEWALK

NOTES:

1. WITH APPROVAL OF THE DOT DIRECTOR, WIDTH OF BOX MAY BE REDUCED TO 6" FOR LOW FLOW LOCATIONS.
2. STEEL SHALL BE 16 GAGE AND SHALL BE HOT DIPPED GALVANIZED.
3. ALL CONCRETE SHALL BE CLASS "1" (6 SACKS PER CUBIC YARD).
4. IF CURB & GUTTER IS EXISTING, CONTRACTOR SHALL SAWCUT & REMOVE THE CURB & GUTTER AND INSTALL 1/2" x 8" DOWELS PER THE EX. SIDEWALK DETAIL.
5. PROVIDE TEMPORARY BLOCKING AT CURB FACE WHILE PLACING CONCRETE TO PREVENT CRUSHING. ENDS OF SHEET METAL BOX SHALL BE SMOOTH AND SQUARE, WITH NO PROTRUDING EDGES. END OF SHEET METAL BOX SHALL BE 1/4" BEHIND CURB FACE.
6. TYPE "B" CURB OUTLET SHALL NOT BE USED IN LOCATIONS WITH A PLANTER STRIP.
7. SEE MENDOT STD. A40 FOR GENERAL NOTES AND DETAILS NOT SHOWN.



**CURB OUTLET
TYPE "B"**

MENDOT
STD. NO.
D51

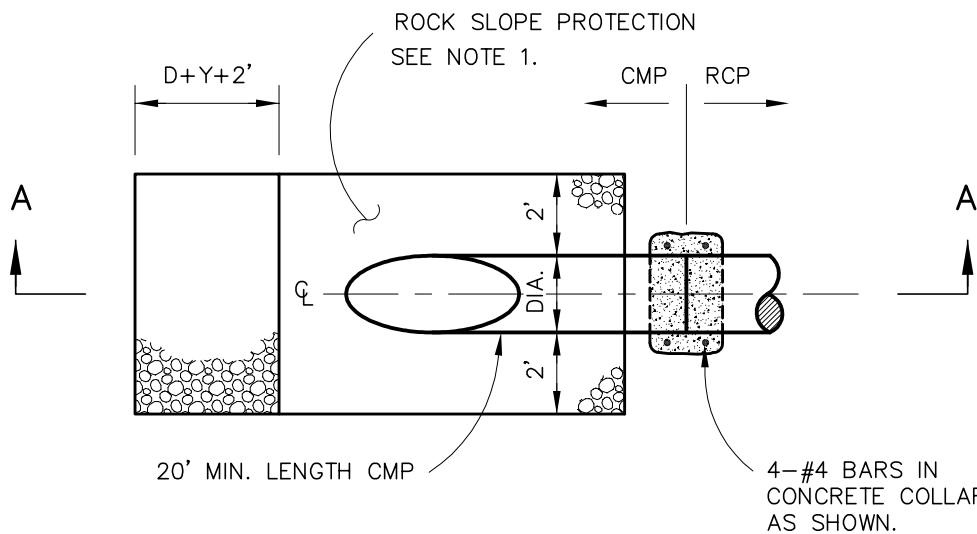

PLAN

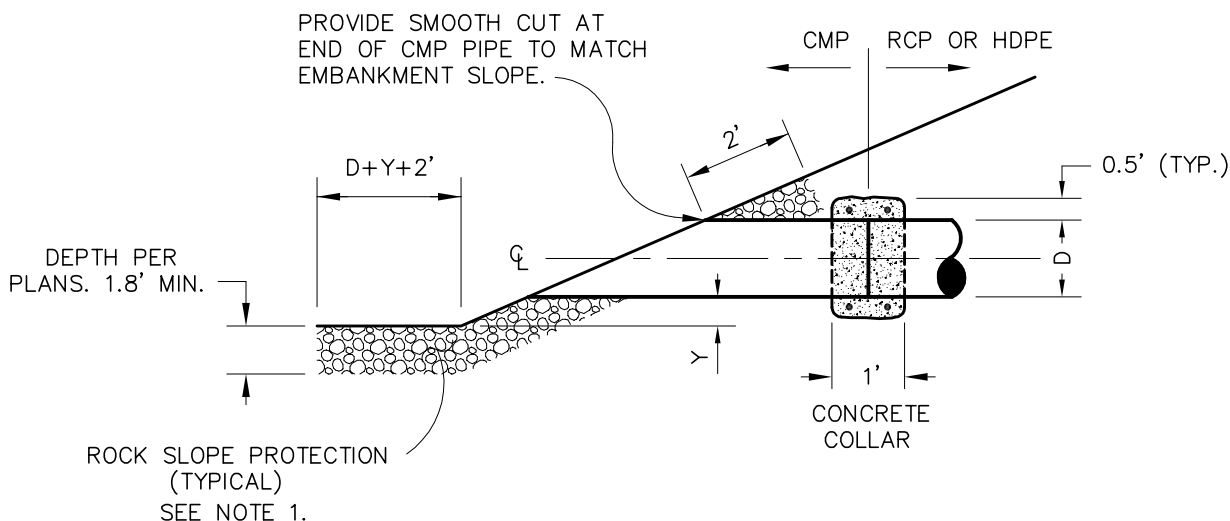

SECTION A-A

NOTES:

1. ROCK SLOPE PROTECTION SHALL BE DESIGNED BY THE ENGINEER IN RESPONSIBLE CHARGE OF THE WORK PER CALTRANS HIGHWAY DESIGN MANUAL. MINIMUM ROCK SLOPE PROTECTION AT STANDARD CMP OUTLET SHALL BE FACING CLASS, PLACEMENT METHOD B, PER SECTION 72 OF THE CALTRANS STANDARD SPECIFICATIONS, SLOPE PROTECTION. MINIMUM THICKNESS SHALL BE 1.8 FEET AND MINIMUM STONE WEIGHT SHALL BE 7 POUNDS. THE USE OF BIOLOGICAL METHODS (E.G. CUTTINGS, BRUSH MATTRESSES) TO PROTECT SLOPES IS ENCOURAGED.
2. DIAMETER OF PIPE SHALL BE DESIGNATED 'D'. HEIGHT ABOVE CREEK BED SHALL BE DESIGNATED 'Y'. WHERE D IS LESS THAN 24", MINIMUM Y SHALL BE 2 FEET. WHERE D IS GREATER THAN OR EQUAL TO 24", MINIMUM Y SHALL BE 1 FOOT.
3. ATTENTION IS DIRECTED TO THE REQUIREMENTS OF THE CALIFORNIA DEPARTMENT OF FISH AND GAME AND THE REGIONAL WATER QUALITY CONTROL BOARD REGARDING STREAMBED ALTERATION. THE CONTRACTOR SHALL BE RESPONSIBLE FOR COMPLIANCE WITH ANY AND ALL PERMIT CONDITIONS.



**CORRUGATED METAL
PIPE OUTLET**

MENDOT
STD. NO.
D60

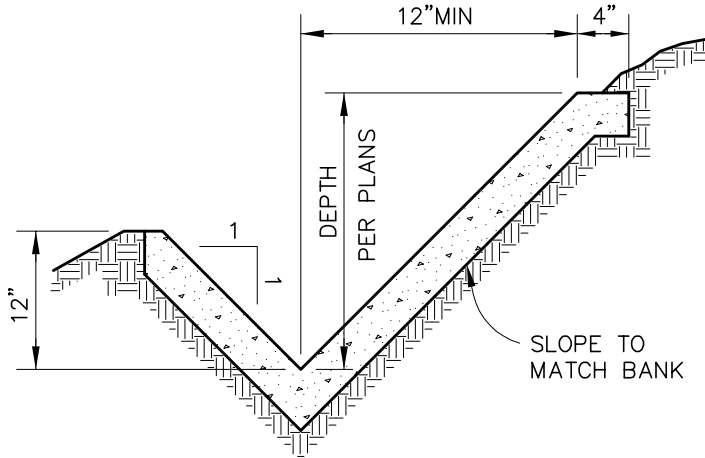

TYPE "A"

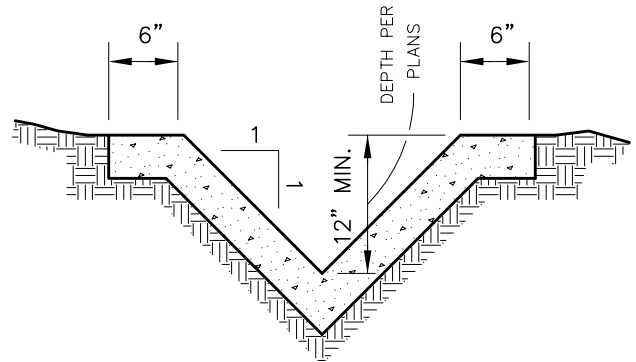

TYPE "B"

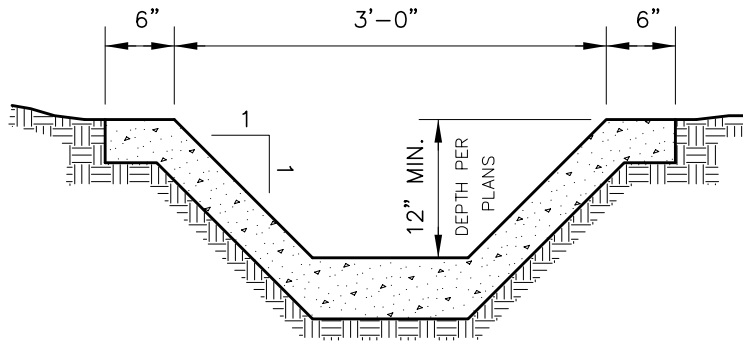

TYPE "C"

NOTE:

1. ALL SECTIONS SHALL BE AT LEAST 4" THICK.
2. CONCRETE SHALL BE CLASS "2" (5 SACK). REINFORCING, #4 AT 24" O.C. EACH WAY, SHALL BE PROVIDED.
3. BOTH SIDES OF THE DITCH SHALL BE FORMED WITH 2"x4" LUMBER, UNLESS OTHERWISE SHOWN ON PLANS.
4. CONCRETE FINISH SHALL BE ORDINARY SURFACE FINISH PER SECTION 51-1.18A OF THE CALTRANS STANDARD SPECIFICATIONS.
5. DITCH SIDES SHALL BE BACKFILLED AND COMPACTED IMMEDIATELY AFTER THE REMOVAL OF SIDE FORMS.
6. NO CONCRETE SHALL BE PLACED PRIOR TO FORM INSPECTION BY THE DOT INSPECTOR.
7. NO DITCH IS TO BE CONSTRUCTED ON FILLED GROUND PRIOR TO CERTIFICATION OF THE FILL TO THE DOT BY THE SOIL ENGINEER.
8. NO EXPANSION JOINTS SHALL BE REQUIRED.
9. CONCRETE-LINED DITCHES SHALL ONLY BE USED OUTSIDE OF THE ROADWAY CLEAR ZONE.



DITCHES, CONCRETE LINED

MENDOT
STD. NO.
D61

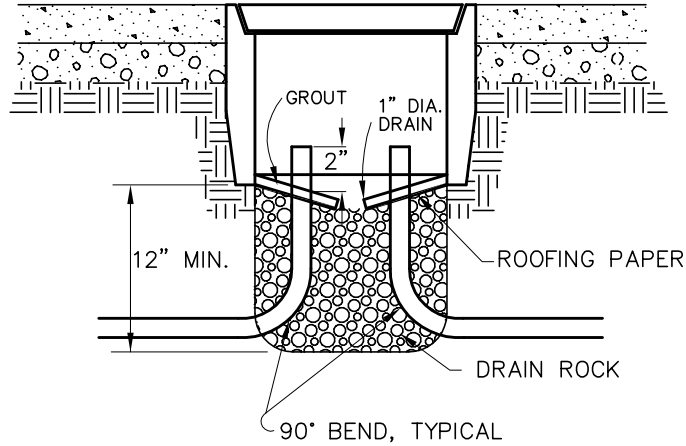

NOTES:

1. ALL PULL BOXES SHALL BE #5 (STATE STD ES-8) EXCEPT THE MAIN TRAFFIC SIGNAL PULL BOX WHICH SHALL BE 30" X 48" MINIMUM.
2. COVERS SHALL BE MARKED "STREET LIGHT", "TRAFFIC SIGNAL", OR "IC" (INTERCONNECT) AS APPROPRIATE.
3. PULL BOXES SUBJECTED TO VEHICULAR TRAFFIC SHALL BE INSTALLED WITH "TRAFFIC COVERS".
4. ALL CONDUITS SHALL BE SEALED WITH AN APPROVED DUCT SEAL. CONDUITS STUBBED FOR FUTURE EXTENSION SHALL BE CAPPED.



**SIGNAL & LIGHTING CONDUIT
AND PULL BOX DETAILS**

MENDOT
STD. NO.
ES10

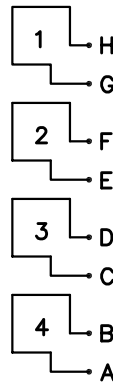
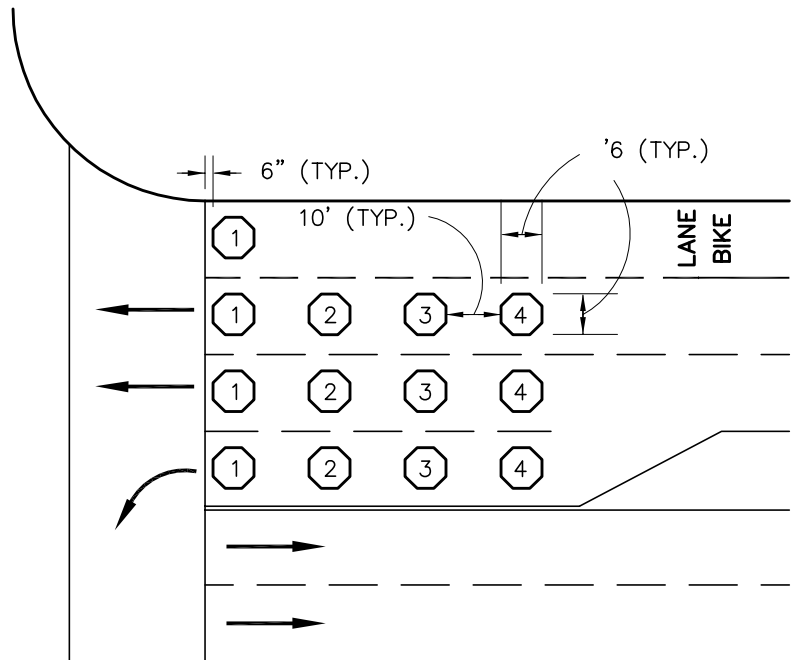
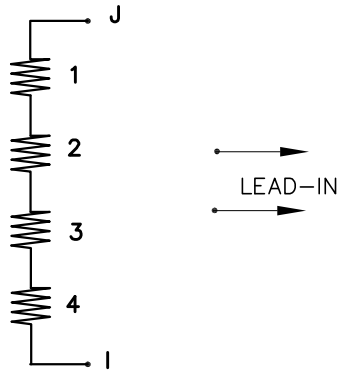

PULL BOX CONNECTIONS

1. CONNECT J TO H
2. CONNECT G TO E
3. CONNECT F TO D
4. CONNECT C TO A
5. CONNECT B TO I

NOTES:

1. LOOPS SHALL BE CENTERED IN LANES.
2. ADJACENT LOOPS ON THE SAME SENSOR UNIT CHANNEL SHALL BE WOUND IN OPPOSITE DIRECTIONS.
3. LOOPS IN ADJACENT LANES SHALL BE WOUND IN OPPOSITE CONFIGURATION.
4. DESIGN SHALL CONFORM TO THESE REQUIREMENTS EXCEPT AS OTHERWISE APPROVED BY THE DOT DIRECTOR
5. ALL DETECTORS LABELED "1" SHALL BE TYPE D PER CALTRANS STD. PLAN ES-5B, TO PROVIDE BICYCLE DETECTION. BICYCLE LOOP DETECTOR SYMBOL PER CALTRANS STD PLAN A24C SHALL BE PLACED OVER AT LEAST ONE THROUGH MOVEMENT DETECTOR LOOP AND SHALL BE LOCATED IN BIKE LANE, WHERE AVAILABLE. BICYCLE LOOP DETECTOR SYMBOL SHALL ALSO BE PLACED OVER LEFT TURN DETECTOR, WHERE INSTALLED.
6. ALL OTHER LOOPS SHALL BE TYPE AND PER CALTRANS STD. PLAN ES-5B.



**SIGNAL
DETECTOR LOOPS**

MENDOT
STD. NO.
ES40

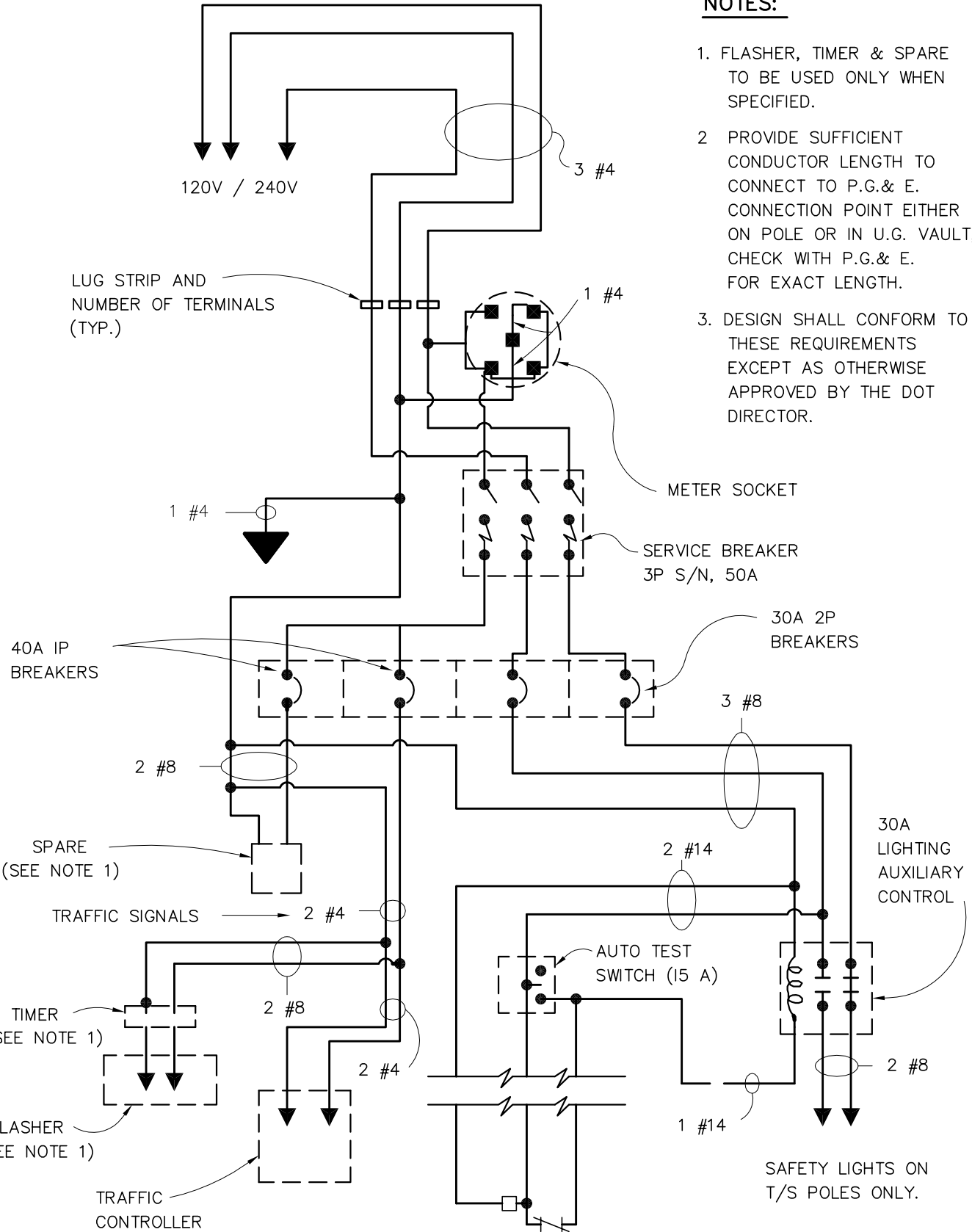

NOTES:

1. FLASHER, TIMER & SPARE TO BE USED ONLY WHEN SPECIFIED.
2. PROVIDE SUFFICIENT CONDUCTOR LENGTH TO CONNECT TO P.G.& E. CONNECTION POINT EITHER ON POLE OR IN U.G. VAULT, CHECK WITH P.G.& E. FOR EXACT LENGTH.
3. DESIGN SHALL CONFORM TO THESE REQUIREMENTS EXCEPT AS OTHERWISE APPROVED BY THE DOT DIRECTOR.



SIGNAL - ELECTRICAL SERVICE WIRING DIAGRAM

MENDOT
STD. NO.
ES41

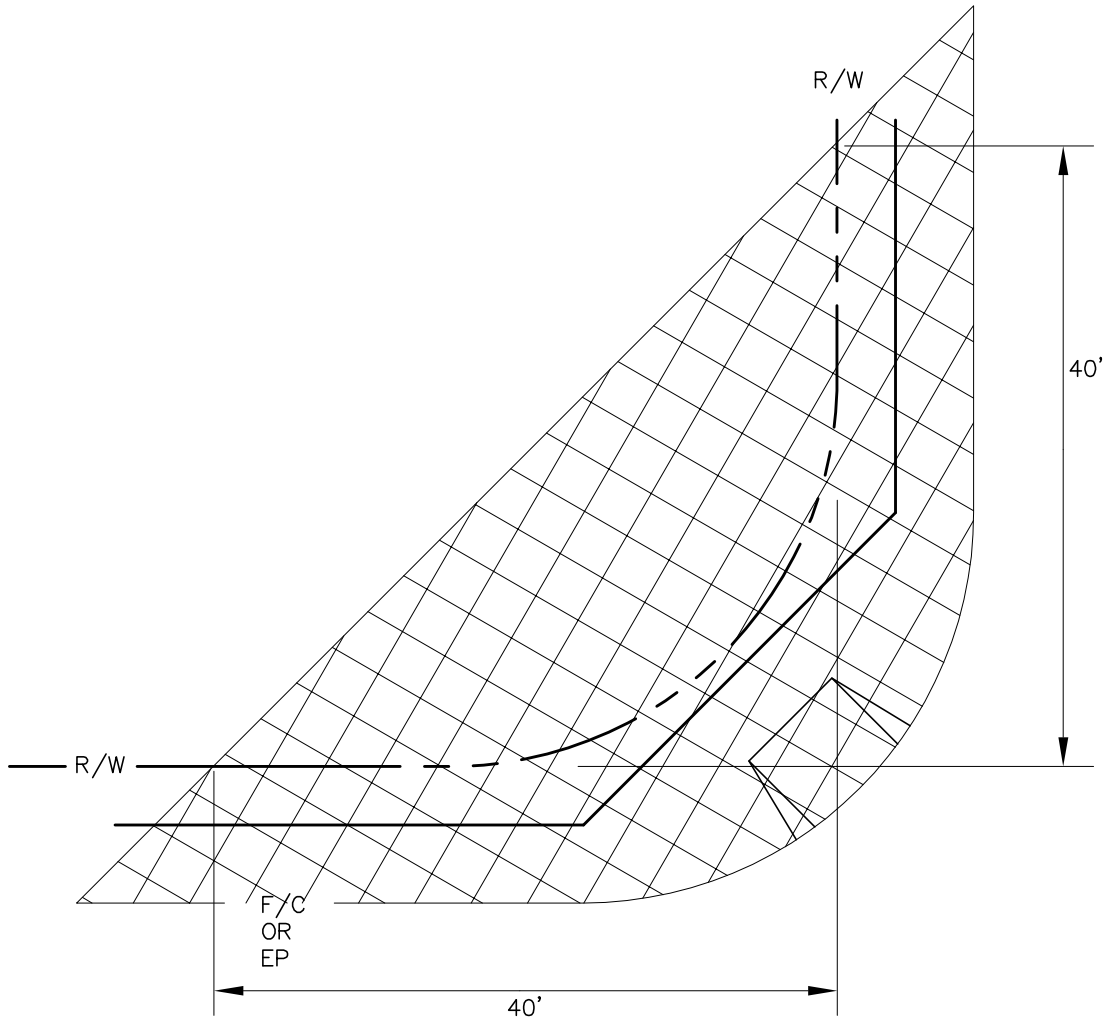

INTERSECTION

NOTES:

1. THIS STANDARD SHALL APPLY ONLY TO URBAN ROADS WITH DESIGN SPEEDS OF 30 MPH OR LESS. SIGHT DISTANCE CONTROL ZONE FOR OTHER ROADS SHALL BE BASED ON MENDOT STD. NO. A53.
2. FENCES AND PLANTING SHALL ALSO CONFORM TO ANY AND ALL REGULATIONS ADMINISTERED BY THE COUNTY OF MENDOCINO DEPARTMENT OF PLANNING AND BUILDING SERVICES.

SIGHT DISTANCE CONTROL ZONE



WITHIN THIS AREA ALL SHRUBS, BUSHES, FENCES AND OTHER IMPROVEMENTS SHALL BE RESTRICTED TO A 3'-6" (42") MAXIMUM HEIGHT, AND TREES SHALL BE MAINTAINED TO PROVIDE A CLEARANCE OF 8'-0" ABOVE THE ROADWAY (MIN.).



**CORNER SIGHT DISTANCE
URBAN
FENCE AND PLANTING STANDARDS**

MENDOT
STD. NO.
H10

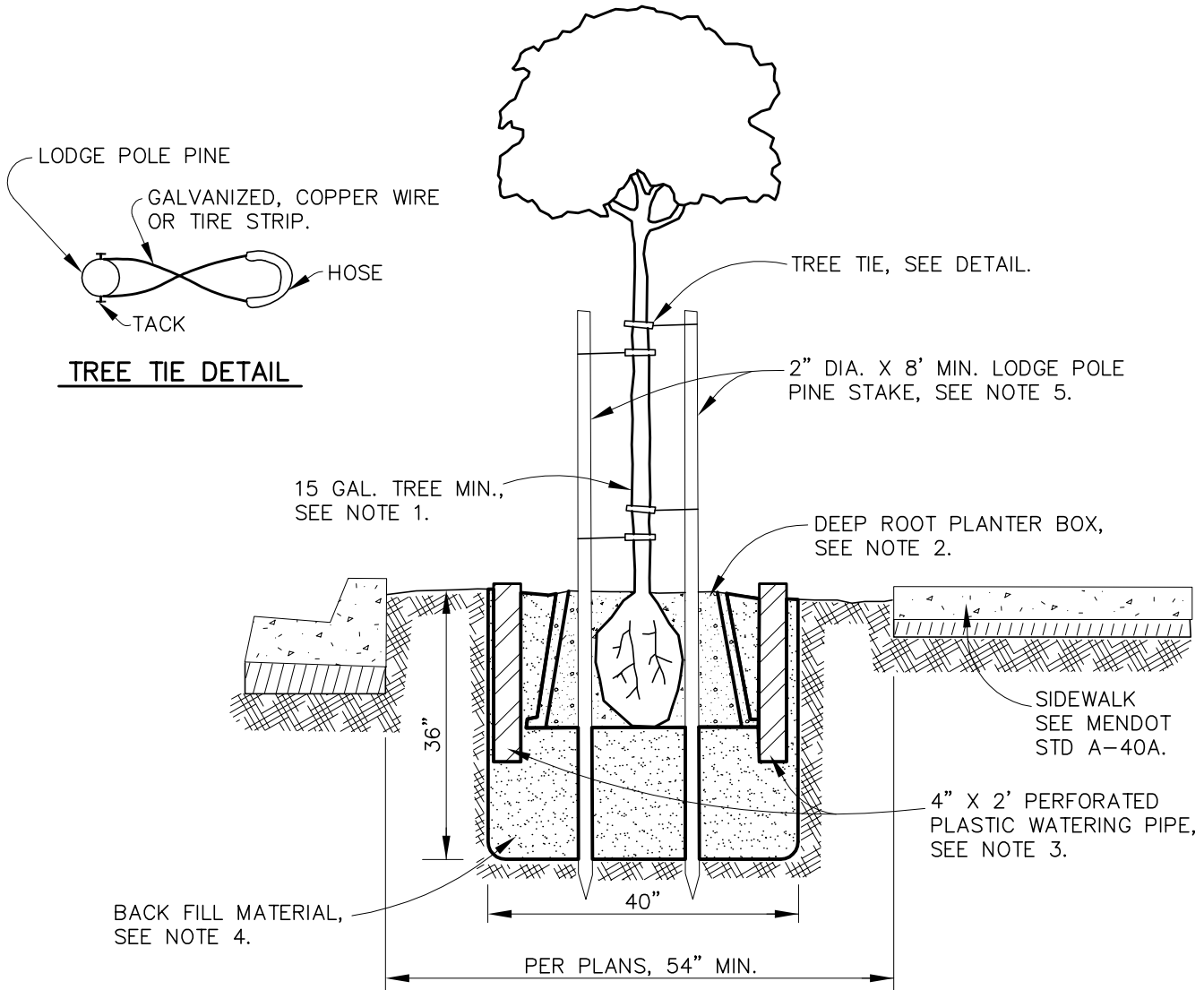

TREE TIE DETAIL

PLANTING DETAIL

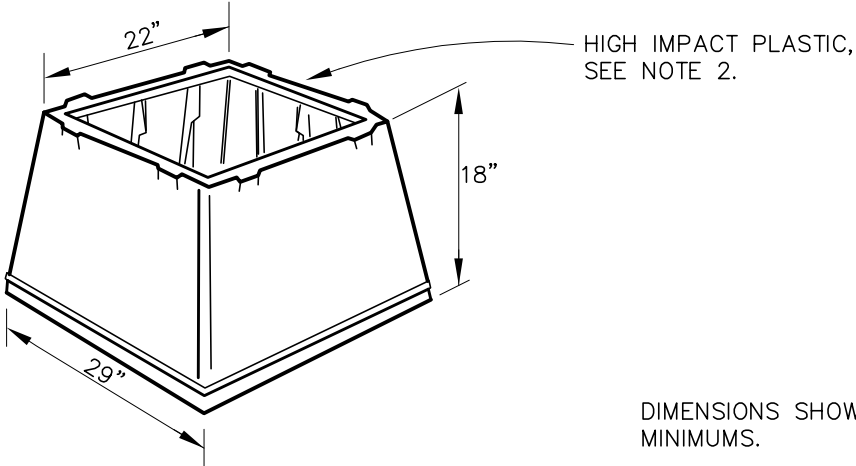

DEEP ROOT PLANTER

DIMENSIONS SHOWN ARE MINIMUMS.

SEE MENDOT STD. H11D FOR REFERENCED NOTES



TREE PLANTING SIDEWALK AREAS

MENDOT
STD. NO.
H11A

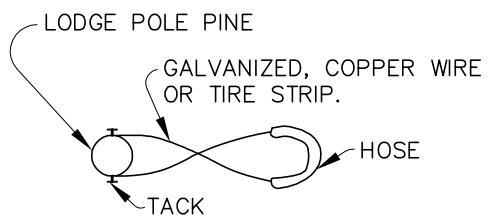

TREE TIE DETAIL

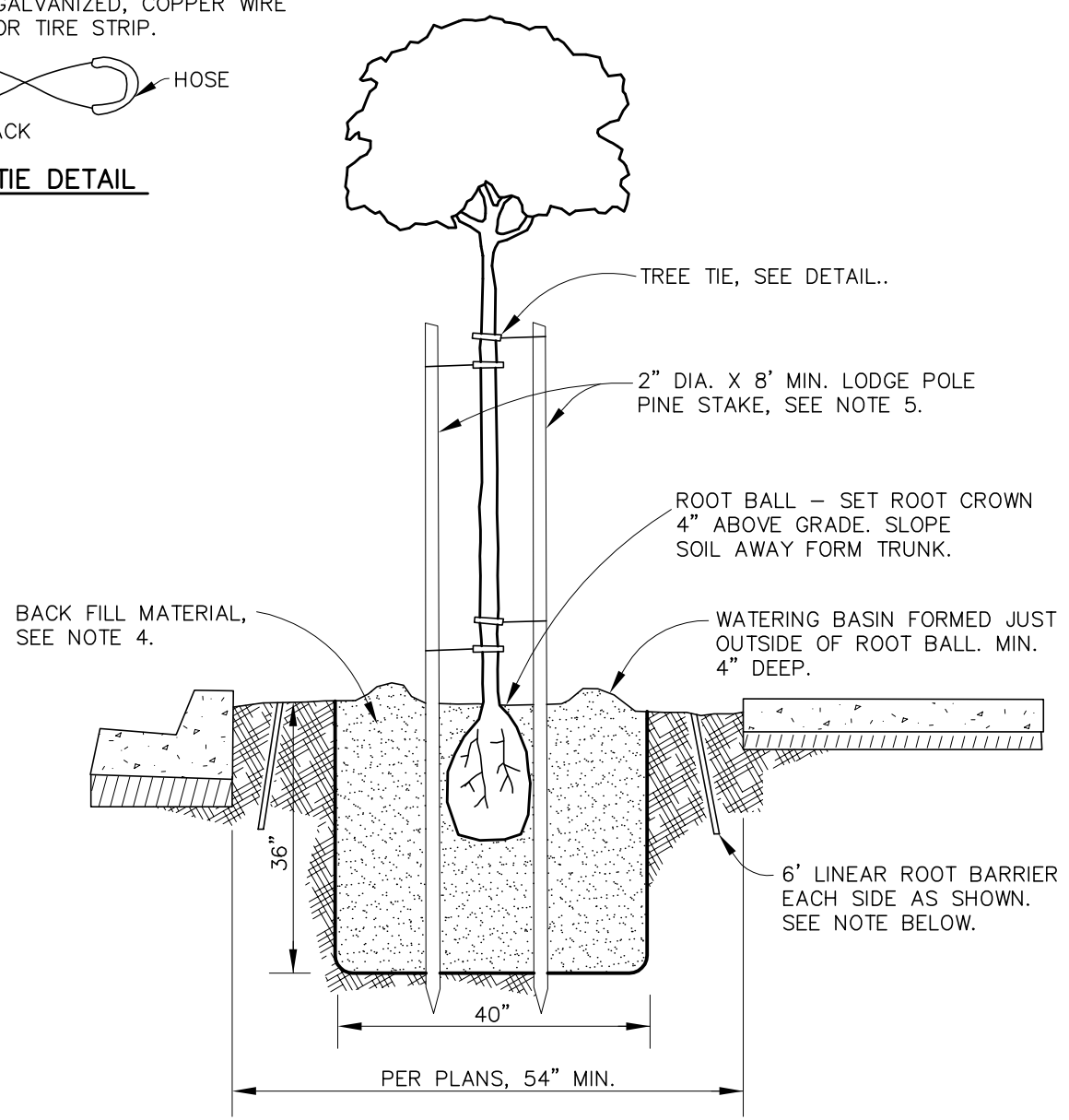

PLANTING DETAIL

NOTES:

ROOT BARRIER MATERIAL SHALL BE APPROVED BY THE DOT DIRECTOR. THE BARRIER SHALL BE PLACED BETWEEN THE TREE AND CURB, AND SIDEWALK. BARRIER SHALL BE A MINIMUM 14" DEEP AND INSTALLED AT A 10° SLANT AS SHOWN.

SEE MENDOT STD. H11D FOR REFERENCED NOTES.

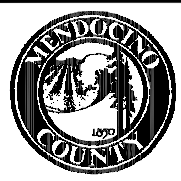

**TREE PLANTING
PARKWAY AREAS**

MENDOT
STD. NO.
H11B

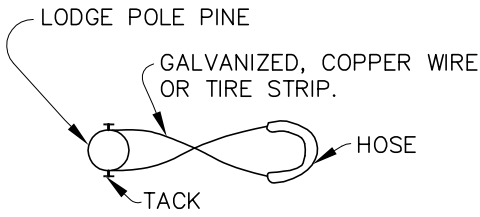

TREE TIE DETAIL

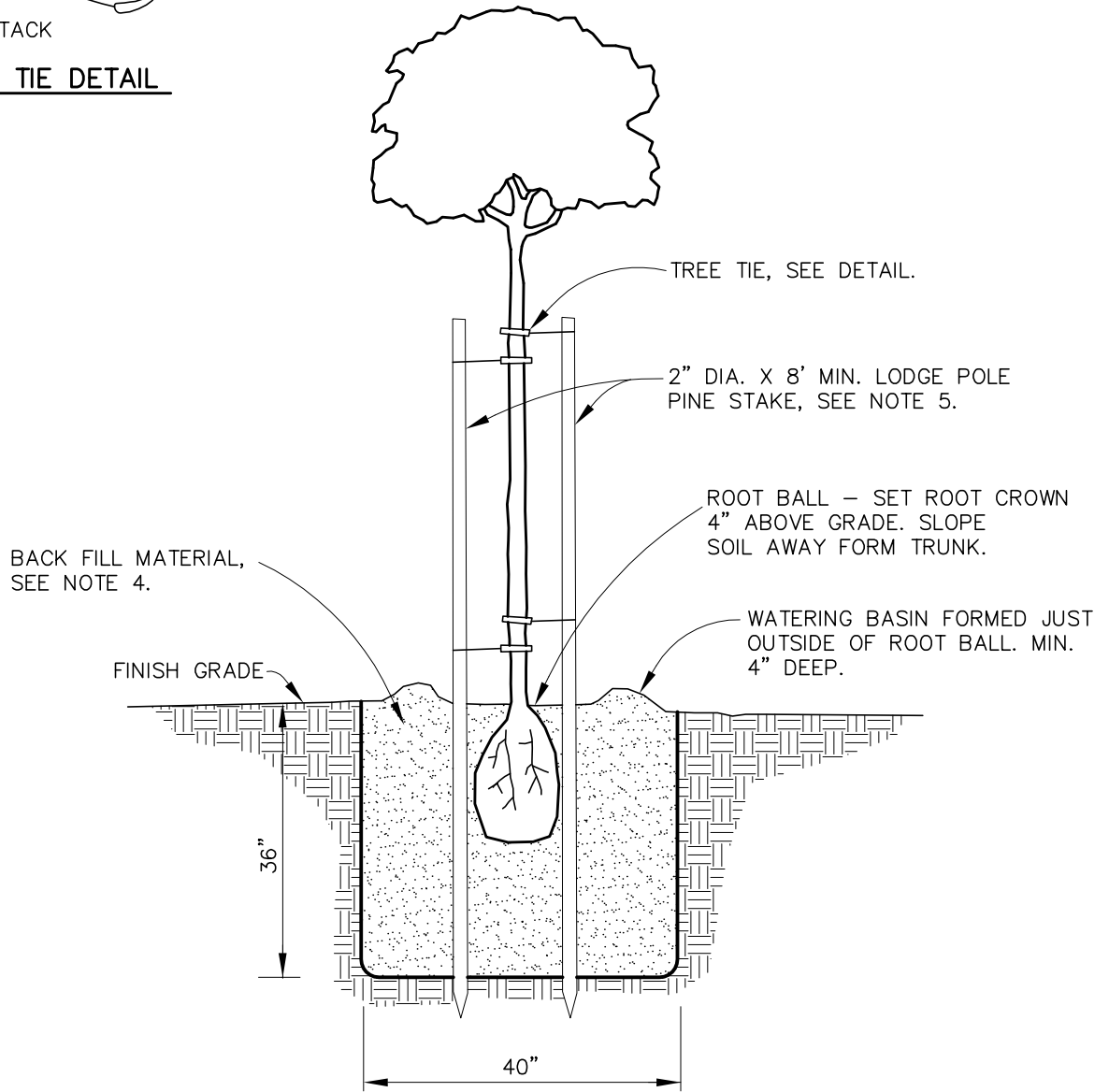

PLANTING DETAIL

SEE MENDOT STD. H11D FOR REFERENCED NOTES.



TREE PLANTING SHOULDER AREAS

MENDOT
STD. NO.
H11C

GENERAL NOTES:

1. TREES SHALL BE OF A SIZE NOT LESS THAN 8 FT. IN HEIGHT NOR LESS THAN 1 INCH CALIPER. A TREE MAY BE REJECTED IF IT IS NOT OF A SHAPE OR CONDITION ACCEPTABLE TO THE COUNTY DOT DIRECTOR OR THE APPROVAL AUTHORITY.
2. TREES IN SIDEWALK AREAS SHALL BE PLANTED IN DEEP ROOT PLANTER BOX. THE PLANTER BOX SHALL BE A MINIMUM OF 22 INCHES AT THE TOP, 29 INCHES AT THE BOTTOM AND 18 INCHES DEEP. DEEP ROOT PLANTER SHALL BE FABRICATED FROM A HIGH DENSITY AND HIGH IMPACT PLASTIC SUCH AS POLYVINYL CHLORIDE, ABS OR POLYETHYLENE AND HAVE A MINIMUM THICKNESS OF 0.06 INCH. THE PLASTIC SHALL HAVE 1/2 INCH HIGH RAISED VERTICAL RIBS ON THE INNER SURFACE SPACED NOT MORE THAN SIX (6) INCHES APART.
3. INSTALL TWO DEEP WATERING PERFORATED PLASTIC PIPES AS SHOWN. FILL PIPES WITH 3/4 INCH CLEAN DRAIN ROCK.
4. TREES SHALL BE PLANTED IN A MIXTURE OF 1/2 NATIVE SOIL AND 1/2 LEAF MOLD OR REDWOOD MULCH.
5. TREES SHALL BE STAKED WITH TWO 2 INCH BY 8 FT. MINIMUM LODGE POLE PINE STAKES OR EQUAL. STAKES SHALL BE COATED WITH GREEN PRESERVATIVE STAIN.
6. TREES SHALL BE PLANTED A MINIMUM OF 20 FT. APART. TREES SHALL BE PLANTED A MINIMUM OF 20 FT. FROM CURB RETURNS, 15 FT. FROM STREET LIGHTS AND 6 FT. FROM DRIVEWAYS, SEWER LATERALS AND WATER SERVICES, OR AS OTHERWISE DIRECTED BY THE COUNTY DOT DIRECTOR.



**STREET TREE PLANTING
NOTES**

MENDOT
STD. NO.
H11D

SCALE: NONE | DESIGN: RCW | DRAWN: LMM | OCT. 2000

PAGE: A-78

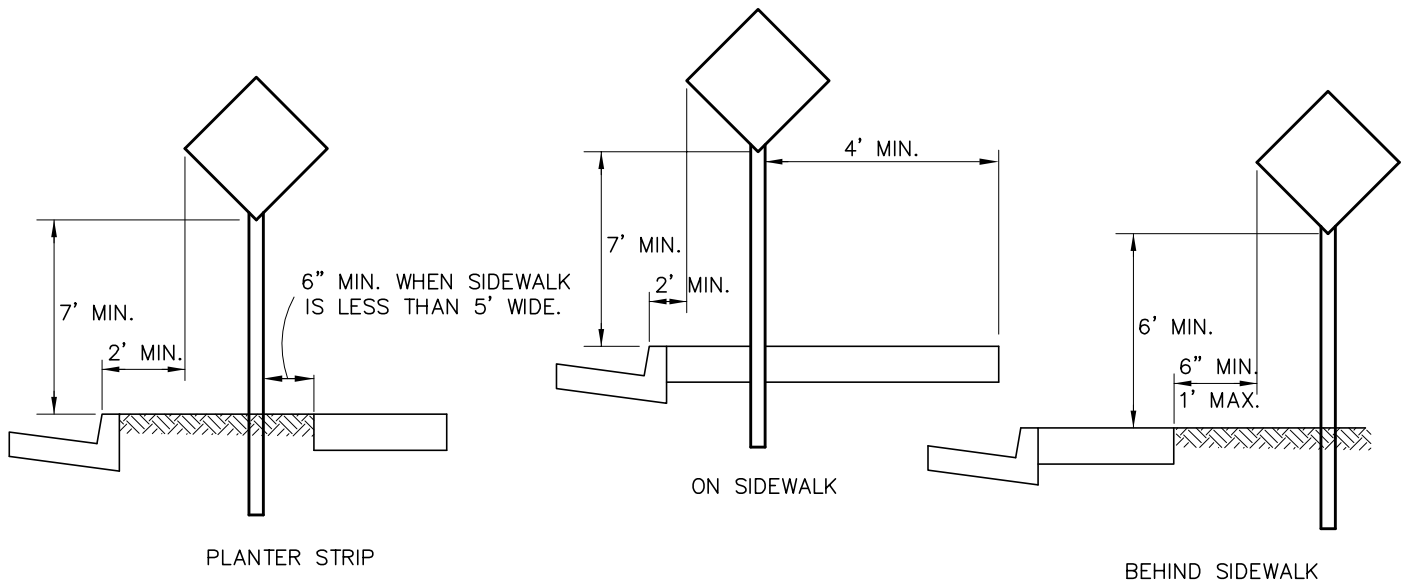

SIDEWALK AREA

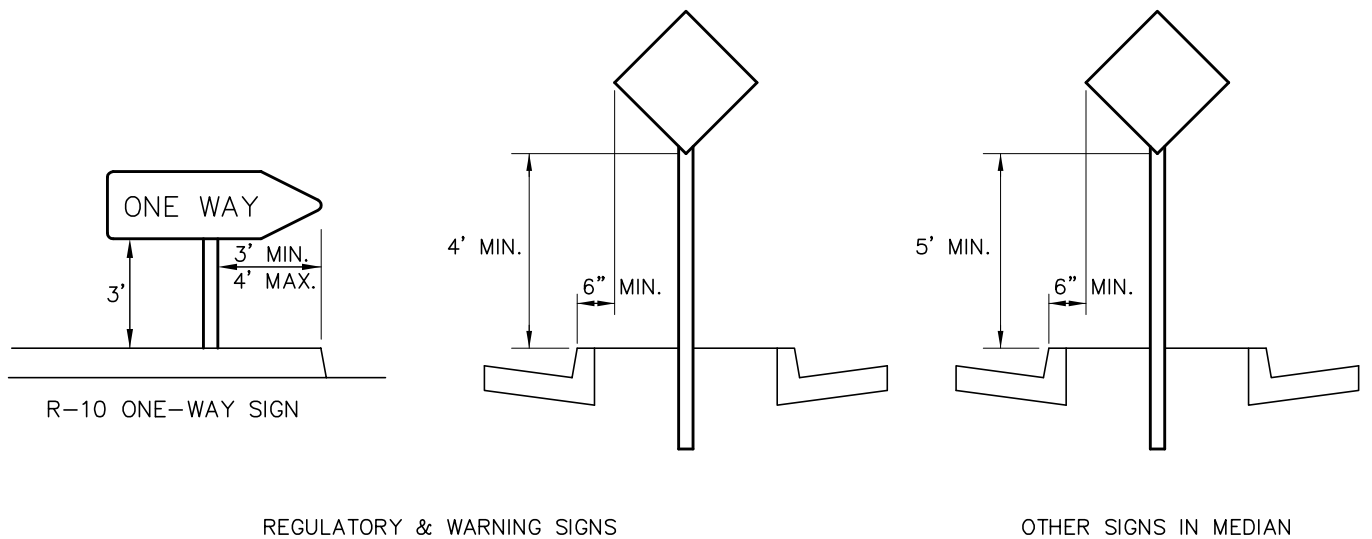

MEDIAN AREA

NOTES:

1. DESIGN SHALL CONFORM TO THESE REQUIREMENTS EXCEPT AS OTHERWISE APPROVED BY THE DOT DIRECTOR.



ROADSIDE SIGN LOCATION—
URBAN AREAS

MENDOT
STD. NO.
RS10

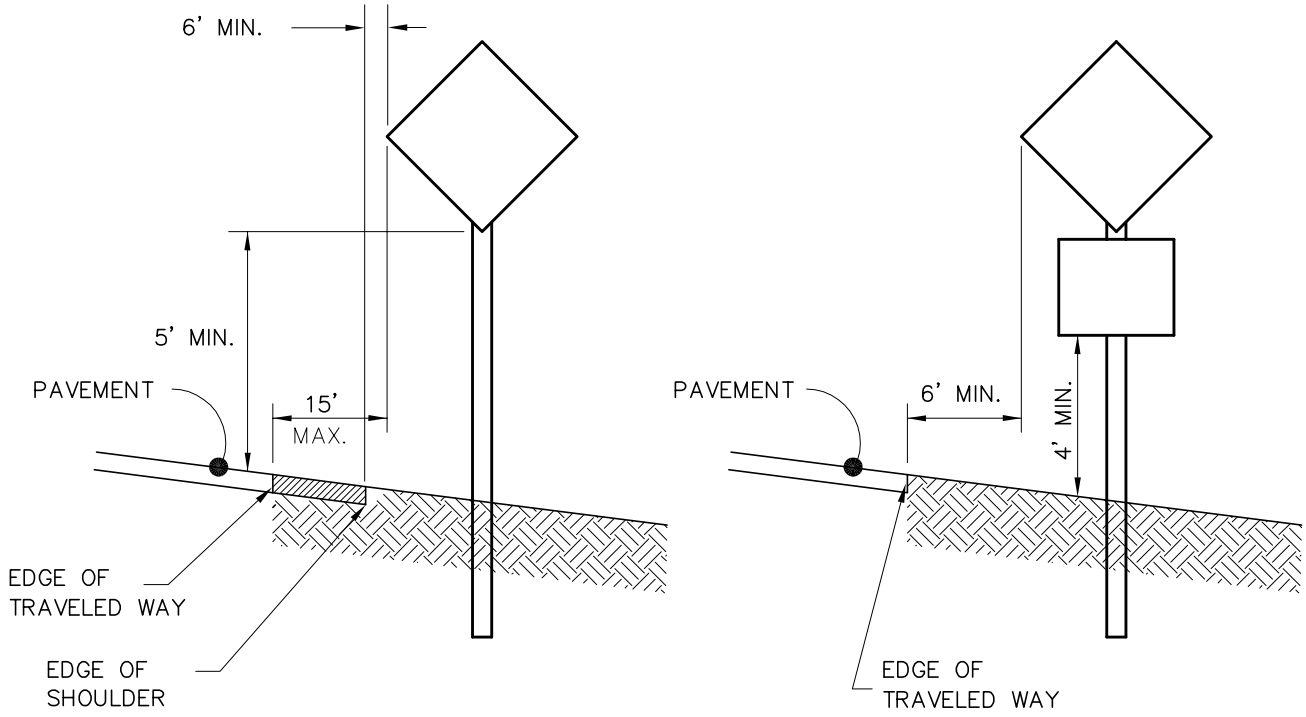

RURAL AREA

NOTES:

- 1. DESIGN SHALL CONFORM TO THESE REQUIREMENTS EXCEPT AS OTHERWISE APPROVED BY THE DOT DIRECTOR.



**ROADSIDE SIGN LOCATION
RURAL AREAS**

MENDOT
STD. NO.
RS11

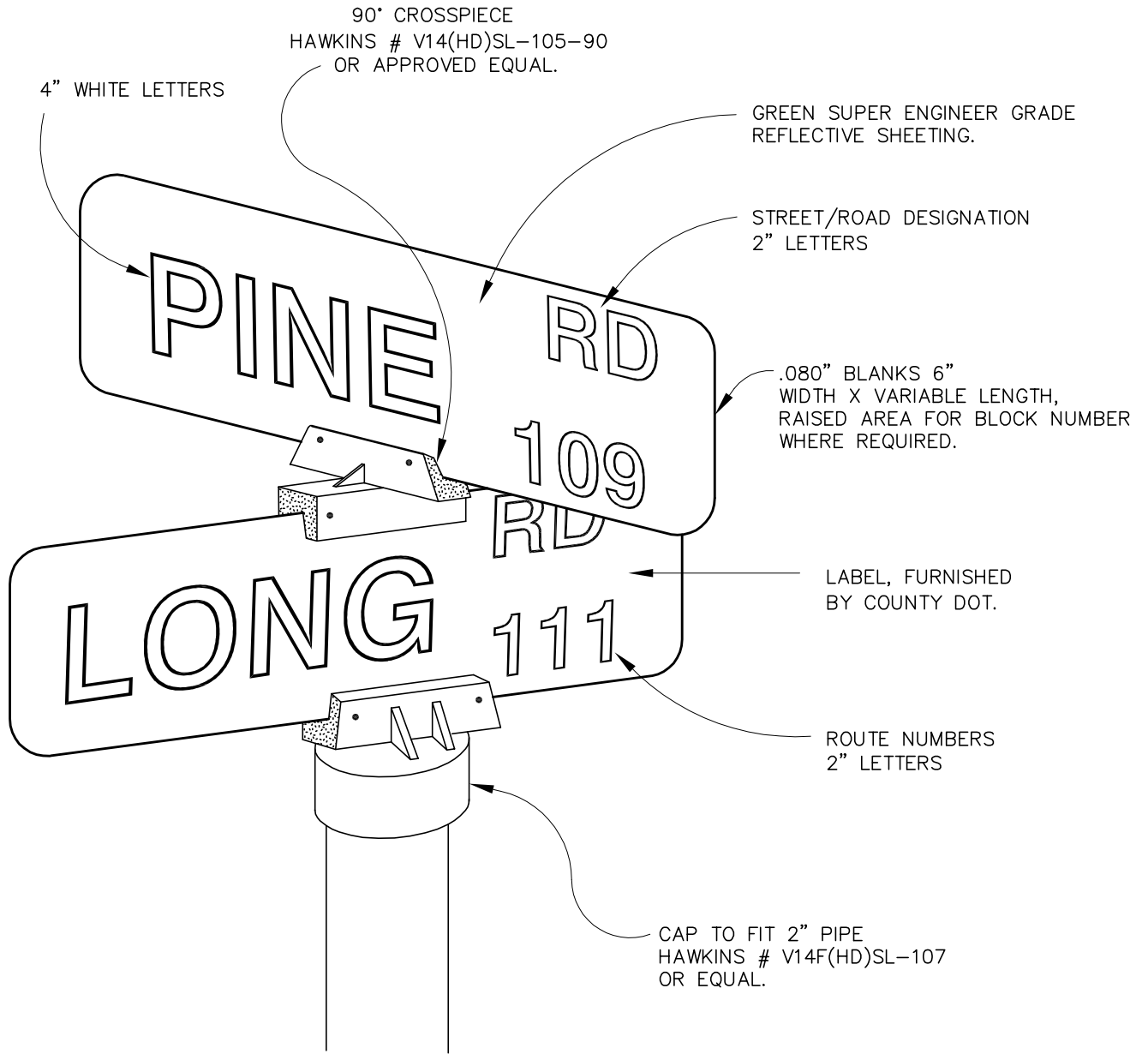

NOTES:

- 1. DETAIL APPLIES TO COUNTY ROADS.
- 2. SIGNS SHALL ALSO COMPLY WITH THE REQUIREMENTS OF THE CALIFORNIA DEPARTMENT FORESTRY AND/OR LOCAL FIRE AGENCY, WHERE THOSE STANDARD ARE MORE RESTRICTIVE.



STREET NAME SIGNS DETAIL

MENDOT
STD. NO.
RS20

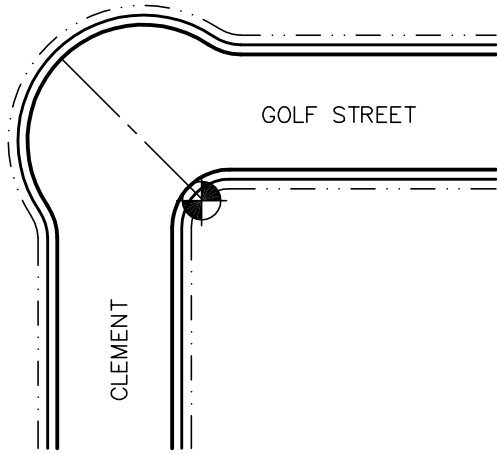

"L" INTERSECTION

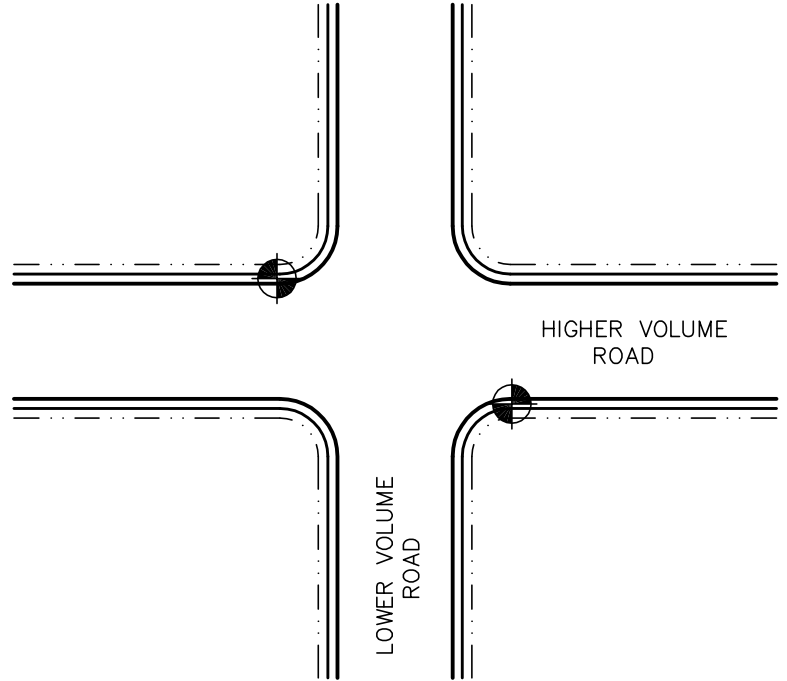

"FOUR WAY" INTERSECTION

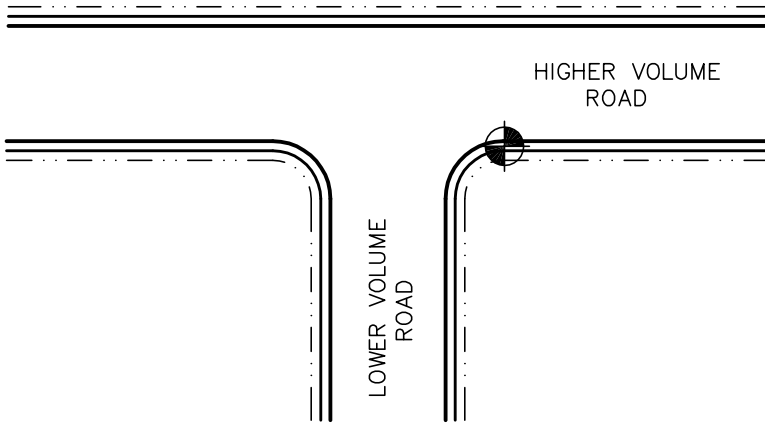

"T" INTERSECTION

LEGEND:

 STREET NAME SIGN

NOTES:

1. DESIGN SHALL CONFORM TO THESE REQUIREMENTS EXCEPT AS OTHERWISE APPROVED BY THE DOT DIRECTOR.



STREET NAME SIGNS TYPICAL LOCATION

MENDOT
STD. NO.
RS21



1 (C18)
Black on Orange
30" X 30"
5" Lettering (C Series)

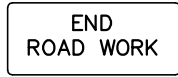

2 (C14)
Black on Orange
42" X 18"
5" Lettering (C Series)

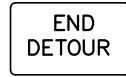

3 (C7)
Black on Orange
30" X 18"
5" Lettering (C Series)



4 (C27)
Black on Orange
24" X 24"
(or 36" x 36" Optional)
4" Lettering (D Series)



5 (C16)
Black on Orange
48" X 48"
7" Lettering (C Series)



6 (C9A)
Black on Orange
48" X 48"



7 (C1)
Black on Orange
48" X 48"
8" Lettering (D Series)

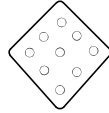

9 (TYPE N MARKER)
Orange
18" X 18"

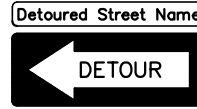

9 (C5)
Black on Orange on Black
48" x 18"
6" Lettering (D Series)
Left & Right



10 (C2)
Black on White
48" x 30"
8" Lettering (D Series)



11 (TYPE N MARKER)
3-3-1/4" Yellow
Reflectors on 15" x 6"
White Plate

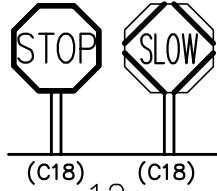

12 (C18)
White on Red and
Black on Orange on Black
24" x 24"-8 Series C Letters
18" x 18"-6" Series C Letters
Non-Reflectorized

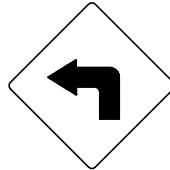

13 (W3)
Black on Orange
36" x 36"
Left & Right

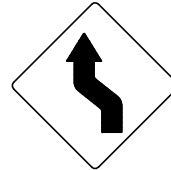

14 (W1)
Black on Orange
36" x 36"
Left & Right



15 (C22B)
Black on Orange
30" x 30"

NOTES:

- Since it is not possible to prescribe detailed standards of application for all situations which may arise, typical standards are presented here for the most common situations. These are desirable standards for normal open street situations, and additional protection should be provided for complicated situations, particularly on high speed or high volume streets. This sheet shall be used in conjunction with the "Manual of Traffic Controls for Construction and Maintenance Work Zones" issued by the State of California, Business, Transportation and Housing Agency, Department of Transportation, latest edition, which shall prevail.
- Delineators shall be placed at 50 foot intervals along lane transitional areas and at 50 foot intervals along construction areas.
- Distance between signs and/or work area may be varied depending on terrain and traffic speed.
- All warning signs or delineators used shall be reflectorized or illuminated.
- During the hours when no work is in progress, Men Working signs (No. 15) and Flagman Ahead signs (No. 6) shall be covered or removed.
- On Portable Flasher Support, the entire area of orange and white shall be reflectorized. Reflectorization shall conform to specifications listed in Section 5-04 "Barricades", of the manual listed in Note 1. The predominant color of the barricade components shall be white.

LEGEND

- Sign (Smooth side faces traffic)
- Delineator
- Portable Flasher Support
- Direction of traffic



16 (C36)
Black on Orange
48" X 48"

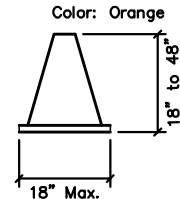

CONE DELINEATOR

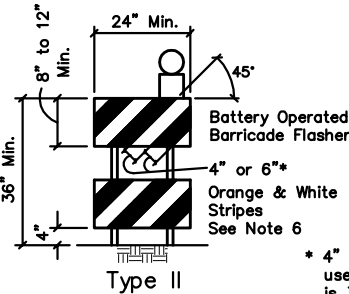

PORTABLE FLASHER SUPPORT BARRICADE

* 4" Stripes may be used if length of rail is 3 feet or less.

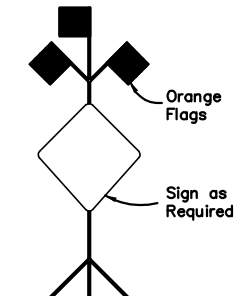

HIGH FLAG STANDARD FOR WORKING SIGNS



TRAFFIC CONTROL SYSTEM FOR CONSTRUCTION ZONES DETAILS

MENDOT STD. NO. **T21**



TRAFFIC CONTROL REQUIREMENTS

MENDOT
STD. NO.
T22A

SCALE: NONE

DESIGN: RCW

DRAWN: CLG

OCT. 2000

PAGE: A-80

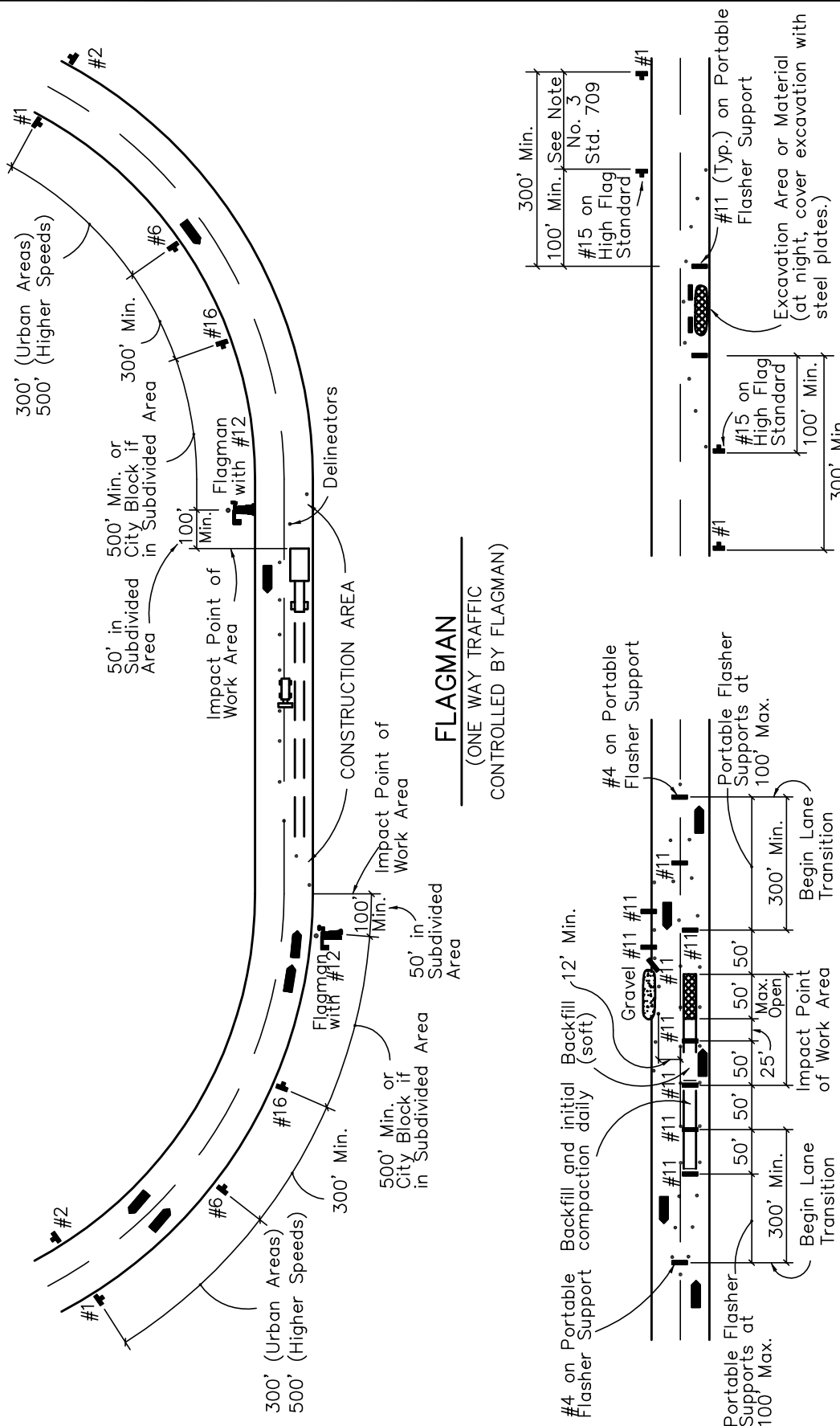

FLAGMAN
(ONE WAY TRAFFIC
CONTROLLED BY FLAGMAN)

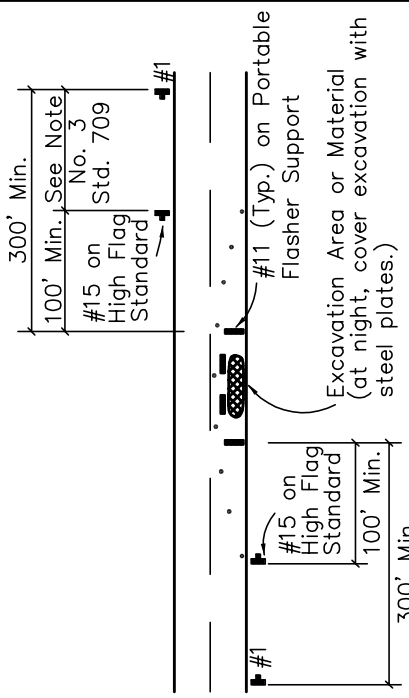

EXCAVATION

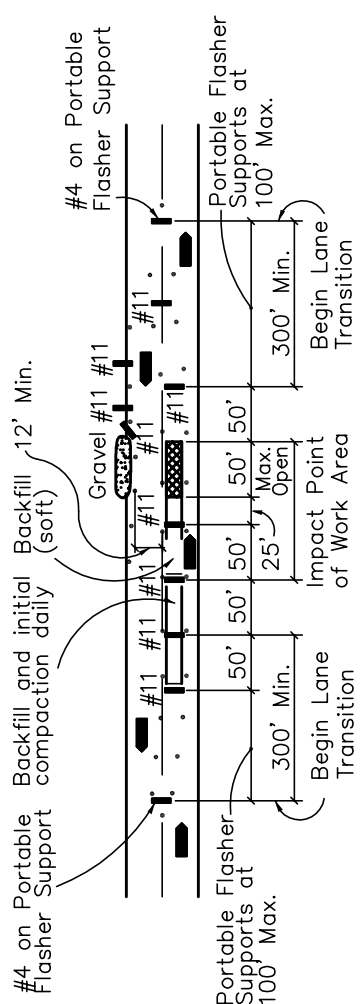

TYPICAL MINIMUM NIGHT REQUIREMENTS
(CONTRACTOR TO INSPECT REGULARLY, ESPECIALLY FLASHERS)

